

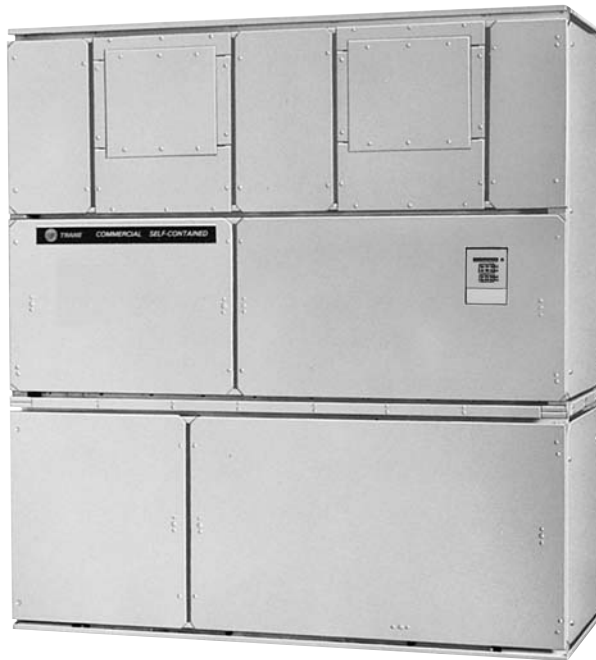

# Installation, Operation, & Maintenance

---

## IntelliPak™ Commercial Self-Contained Modular Series, 20-35 tons



### "JO" and later design sequence

#### Models:

SCWG -020, -025, -030, -032, -035

SIWG -020, -025, -030, -032, -035

SCRG -020, -025, -030, -032

SIRG -020, -025, -030, -032



# Introduction

## About This Manual

### Literature Change History

Use this manual for commercial self-contained models SCWG, SIWG, SCRG, and SIRG. This is the second or "B" revision of this manual. It provides specific installation, operation, and maintenance, instructions for "JO" and later design sequences. The "JO" design sequence includes the addition of 407c refrigerant option and VFD change from Square D 58 to the Trane TR-1. Also, this literature contains changes in the filter sizes and quantities for some unit sizes. For previous design sequences, contact your local Trane representative.

### Hazard Identification

Warnings and cautions appear at appropriate sections throughout this manual. Read these carefully.

#### WARNING

Indicates a potentially hazardous situation, which could result in death or serious injury if not avoided.

#### CAUTION

Indicates a potentially hazardous situation, which may result in minor or moderate injury if not avoided. Also, it may alert against unsafe practices.

#### NOTICE

Indicates a situation that may result in equipment or property-damage-only accidents.

#### WARNING

##### Grounding Required!

Follow proper local and state electrical code on requirements for grounding. Failure to follow code could result in death or serious injury.

### Sample Warnings and Cautions

#### WARNING

##### Hazardous Voltage w/Capacitors!

**Disconnect all electric power, including remote disconnects before servicing. Follow proper lockout/tagout procedures to ensure the power cannot be inadvertently energized. For variable frequency drives or other energy storing components provided by Trane or others, refer to the appropriate manufacturer's literature for allowable waiting periods for discharge of capacitors. Verify with an appropriate voltmeter that all capacitors have discharged. Failure to disconnect power and discharge capacitors before servicing could result in death or serious injury.**

**Note: For additional information regarding the safe discharge of capacitors, see PROD-SVB06A-EN or PROD-SVB06A-FR.**

#### NOTICE

##### Use Copper Conductors Only!

Unit terminals are not designed to accept other type conductors. Failure to use copper conductors may result in equipment damage.

#### Common HVAC Acronyms

For convenience, a number of acronyms and abbreviations are used throughout this manual. These acronyms are alphabetically listed and defined below.

BAS = Building automation systems  
CFM = Cubic-feet-per-minute  
CKT. = Circuit  
CV = Constant volume  
CW = Clockwise  
CCW = Counterclockwise  
E/A = Exhaust air  
ECEM = Exhaust/comparative enthalpy module  
F/A = Fresh air  
GBAS = Generic building automation system  
HGBP = Hot gas bypass  
HI = Human Interface

HVAC = Heating, ventilation and air conditioning  
IGV = Inlet guide vanes  
I/O = Inputs/outputs  
IOD= Installation/owner/ diagnostic manual  
IPC = Interprocessor communications  
IPCB = Interprocessor communications bridge  
LH = Left-hand  
MCM = Multiple compressor module  
MWU = Morning warmup  
NSB = Night setback  
O/A = Outside air  
psig = Pounds-per-square-inch, gauge pressure  
R/A = Return air  
RH = Right-hand  
RPM = Revolutions-per-minute  
RTM = Rooftop module  
S/A = Supply air  
SCM = Single circuit module  
SZ = Single-zone (unit airflow)  
LCI-I communications module  
UCM = Unit control modules  
VAV = Variable air volume  
VCM = Ventilation control module  
VOM = Ventilation override module  
w.c. = Water column  
WSM = Waterside module  
ZSM = Zone sensor module

### Special Note on Refrigeration Emissions

World environmental scientists have concluded that ozone in our upper atmosphere is being reduced due to the release of CFC fully halogenated compounds.

Trane urges all HVAC service personnel to make every effort to prevent any refrigerant emissions while installing, operating, or servicing equipment. Always conserve refrigerants for continued use.

# Contents

---

**Cross reference to related publications/information:**

- *Product Catalog, PKG-PRC003-EN, Modular Series Commercial Self-Contained*
- *IntelliPak Self-Contained Programming Guide, PKG-SVP01B-EN*
- *Remote Air-Cool-Condenser Installation, Owner, and Diagnostic Manual, CXRC-SVX01B-EN*

<b>Installation</b>	<b>6</b>
general information	6
pre-installation considerations...	11
dimensions & weights	19
mechanical specifications	30
electrical requirements	33
pre-startup requirements	35
programming	57
startup	67
<b>Operation</b>	<b>70</b>
general information	70
sequence of operation	84
<b>Maintenance</b>	<b>91</b>
maintenance procedures	92
troubleshooting	105
diagnostics	106



# Features and Benefits

---

## Refrigerant Handling Procedures

### Environmental Accountability Policy

Trane urges that all HVAC servicers to make every effort to eliminate, if possible, or vigorously reduce the emission of CFC, HCFC, and HFC refrigerants to the atmosphere. Always act in a responsible manner to conserve refrigerants for continued usage even when acceptable alternatives are available.

### Recover and Recycle Refrigerants

Never release refrigerant to the atmosphere! Always recover and/or recycle refrigerant for reuse, reprocessing (reclaimed), or properly dispose if removing from equipment. Always determine the recycle or reclaim requirements of the refrigerant before beginning the recovery procedure. Obtain a chemical analysis of the refrigerant if necessary. Questions about recovered refrigerant and acceptable refrigerant quality standards are addressed in ARI Standard 700.

### Refrigerant Handling and Safety

Consult the manufacturer's material safety data sheet (MSDS) for information on refrigerant handling to fully understand health, safety, storage, handling, and disposal requirements. Use the approved containment vessels and refer to appropriate safety standards. Comply with all applicable transportation standards when shipping refrigerant containers.

### Service Equipment and Procedures

To minimize refrigerant emissions while recovering refrigerant, use the manufacturer's recommended recycling equipment per the MSDS. Use equipment and methods which will pull the lowest possible system vacuum while recovering and condensing refrigerant. Equipment capable of pulling a vacuum of less than 1,000 microns of mercury is recommended.

Do not open the unit to the atmosphere for service work until refrigerant is fully removed/recovered. When leak-testing with trace refrigerant and nitrogen, use HCFC-22 (R-22) rather than CFC-12 (R-12) or any other fully-halogenated refrigerant. Be aware of any new leak test methods which may eliminate refrigerants as a trace gas. Perform evacuation prior to charging with a vacuum pump capable of pulling a vacuum of 1,000 microns of mercury or less. Let the unit stand for 12 hours and with the vacuum not rising above 2,500 microns of mercury.

A rise above 2,500 microns of mercury indicates a leak test is required to locate and repair any leaks. A leak test is required on any repaired area.

Charge refrigerant into the equipment only after equipment does not leak or

contain moisture. Reference proper refrigerant charge requirements in the maintenance section of this manual to ensure efficient machine operation. When charging is complete, purge or drain charging lines into an approved refrigerant container. Seal all used refrigerant containers with approved closure devices to prevent unused refrigerant from escaping to the atmosphere. Take extra care to properly maintain all service equipment directly supporting refrigerant service work such as gauges, hoses, vacuum pumps, and recycling equipment.

When cleaning system components or parts, avoid using CFC-11 (R-11) or CFC-113 (R-113). Use only cleaning-solvents that do not have ozone depletion factors. Properly dispose of used materials. Refrigeration system cleanup methods using filters and driers are preferred.

Keep abreast of unit enhancements, conversion refrigerants, compatible parts, and manufacturer's recommendations that will reduce refrigerant emissions and increase equipment operating efficiencies.

## Features and Benefits

### Modular Series Self-Contained Unit Components

Commercial self contained units are complete HVAC systems used in floor-by-floor applications. Units are easy to install because they feature a single point power connection, factory installed and tested controls, single water point connection, factory installed options, and an internally trapped drain connection. Modular self-contained units can ship as split-apart units for installation ease. Split-apart units ship with a dry nitrogen charge and require field refrigerant charging.

Units consist of multiple compressors, water-cooled condensers (water-cooled units only), an evaporator coil, dual forward curved fans, and control panel. Air-cooled units require a remote air-cooled condenser, model CXRC. The hermetically sealed 3-D scroll compressor motors utilize internal motor protection and time delays to prevent excessive cycling. Unit controls are either an electromechanical thermostat or microprocessor controls on the IntelliPak unit. See Figure I-GI-1 for a typical unit.

The hermetically sealed 3-D scroll compressor motors utilize internal motor protection and time delays to prevent excessive cycling.

The water-cooled condensers are shell and tube type with an internal subcooler. Condensers are available as mechanically or chemically cleanable. The evaporator fan is double width, double inlet and forward curved with a fixed pitch belt drive assembly. Frequency drives or inlet guide vanes are optional. Motor options include open drip proof, high efficiency, TEFC, or mill and chem spec.

All water-cooled units ship with a full refrigerant and oil charge. Air-cooled units ship with oil and a dry nitrogen holding charge and require field-piping

refrigerant connections to the air cooled condensing unit. Also, air-cooled units have two refrigerant circuits. Water-cooled units have four refrigerant circuits; which include a filter drier, pressure relief valve, liquid line service valve, sight glass/moisture indicator, thermal expansion valve with a sensing bulb and external equalizing line, discharge line shradar valve, a suction line shradar valve, and high and low pressure cutout switches. Water-cooled units also include a liquid line service valve for each circuit.

For more detailed information, see the Owner's section of this manual.



Figure I-GI-1. IntelliPak® commercial self-contained Modular Series unit.



# Installation

# general information

### Control Options

Units may be ordered with either conventional thermostat interface or IntelliPak™ Direct Digital Control (DDC). IntelliPak™ controls include a Human Interface (HI) panel with two line by forty (40) character clear English display for easy operator interface to unit setup and control parameters. All basic setup parameters are preset from the factory.

### Human Interface Panel

The HI is unit mounted and accessible without opening the unit's front panel. It allows easy setpoint adjustment using the HI keypad. In addition, the HI displays all unit operating parameters and conditions in a clear language display, which can be configured for either English, French, or Spanish.

The optional remote human interface (RHI) will control up to four self-contained units, each containing an interprocessor communications bridge (IPCB). It has all the same features as the unit-mounted HI except for the service mode.

For more information on setpoint defaults and ranges and unit programming, see the *IntelliPak Self-Contained Programming Guide, PKG-SVP01B-EN*. A copy ships with each unit.

### IntelliPak™ DDC Control

IntelliPak™ DDC Control provides "smart" unit control with safety features and control relays for pumps, dampers, etc. The Modular Series IntelliPak self-contained unit is controlled by a microelectronic control system that consists of a network of modules. These modules are referred to as unit control modules (UCM). In this manual, the acronym UCM refers to the entire control

system network.

These modules perform specific unit functions using proportional/integral control algorithms. They are mounted in the unit control panel and are factory wired to their respective internal components. Each module receives and interprets information from other unit modules, sensors, remote panels, and customer binary contacts to satisfy the applicable request; i.e., economizing, mechanical cooling, heating, ventilation. See the Operation section of this manual for a detailed description of each module's function.

### Optional Controls

Optional controls include a disconnect switch, dirty filter switch, water flow switch (water-cooled only), supply air temperature reset, or external setpoint inputs. Daytime heating is available on units with electric, steam, or hot water heat control options. Morning warmup operation is available on all units.

The static pressure probe, zone night heat/morning warmup, supply air temperature reset sensor options ship separate inside the unit control panel for field installation. For more detailed information on the unit control options, see the Owner's section of this manual.

### Unit Nameplate

The unit nameplate identifies the unit model number, appropriate service literature, and wiring diagram numbers. It is mounted on the left end of the unit control panel.



# Model Number Description

## SCWG

### Model Number Description

Each IntelliPak self-contained unit has a multiple character model number unique to that unit. To determine a unit's specific options, reference the model number on the unit nameplate using the model number explanation below.

S C W G N 20 4 2 JO A B 2 10 085 B A 1 0 1 0 A A C F A 1 1 0 T 2 0  
1 2 3 4 5 67 8 9 10 11 12 13 14 15 16 17 18 19 20 21 22 23 24 25 26 27 28 29 30 31 32 33 34 35 36

#### Digit 1 - Unit Model

S = Self Contained

#### Digit 2 - Unit Type

C = Commercial

I = Industrial

#### Digit 3 - Condenser Medium

W = Water-Cooled

R = Remote Air-Cooled

#### Digit 4 - Development Sequence

G = Modular Series

#### Digit 5 - Refrigerant Circuit Configuration

N = Independent, R-22 Refrigerant

R = Independent, 407C Refrigerant

#### Digit 6, 7 - Unit Nominal Capacity

20 = 20Tons (Water or Air Cooled)

25 = 25Tons (Water or Air Cooled)

30 = 30Tons (Water Cooled Only)

32 = 32Tons (Air Cooled Only)

35 = 35Tons (Water Cooled Only)

#### Digit 8 - Unit Voltage

6 = 200 Volt/60 Hz/3 ph

4 = 460 Volt/60 Hz/3 ph

5 = 575 Volt/60 Hz/3 ph

#### Digit 9 - Air Volume/Temp Control

1 = I-Pak & IGW and Supply Air Temp Ctrl

2 = I-Pak & VFD and Supply Air Temp Ctrl

3 = I-Pak & VFD w/ Bypass and Supply Air Temp Ctrl

4 = I-Pak w/o Vol. CTRL, w/ Zone Temp Cool

5 = I-Pak w/o Vol. CTRL, w/ Zone Temp Heat/Cool

6 = I-Pak w/o Vol. CTRL, w/ Supply Air Temp Ctrl

8 = Thermostat Interface

#### Digit 10, 11 - Design Sequence

JO = "J" Design

#### Digit 12 - Unit Construction

A = Vertical Discharge

B = Vertical Discharge with Double Wall

C = Horizontal Discharge

D = Horizontal Discharge w/ Double Wall

E = Vertical Discharge, Ship Separate

F = Vertical Discharge w/ Double Wall, Ship Separate

G = Horizontal Discharge, Ship Separate

H = Horizontal Discharge w/ Double Wall, Ship Separate

#### Digit 13 - Plenum Type

B = Std Plenum w/ Factory Cut Holes

C = Low Plenum w/ Factory Cut Holes

E = Std Plenum w/ Field Cut Holes

F = Low Plenum w/ Field Cut Holes

H = Std Plenum Double Wall (Perf) w/ Field Cut Holes

J = Low Plenum Double Wall (Perf) w/ Field Cut Holes

L = Std. Plenum w/Factory Cut Holes, Ship Separate

M = Low Plenum with Factory Cut Holes, Ship Separate

P = Std Plenum w/ Field Cut Holes, Ship Separate

R = Low Plenum w/ Field Cut Holes, Ship Separate

U = Std Plenum Double Wall (Perf) w/ Field Cut Holes, Ship Separate

V = Low Plenum Double Wall (Perf) w/ Field Cut Holes, Ship Separate

0 = Without Plenum

#### Digit 14 - Motor Type

1 = Std. Efficiency ODP

2 = Premium Eff. ODP

3 = Std. Efficiency Totally Enclosed

#### Digit 15, 16 - Motor HP

05 = 5 HP Motor

07 = 7.5 HP Motor

10 = 10 HP Motor

15 = 15 HP Motor

20 = 20 HP Motor

25 = 25 HP Motor

#### Digit 17, 18, 19 - Fan RPM

085 = 850 rpm

090 = 900 rpm

095 = 950 rpm

100 = 1000 rpm

105 = 1050 rpm

110 = 1100 rpm

115 = 1150 rpm

120 = 1200 rpm

125 = 1250 rpm

130 = 1300 rpm

135 = 1350 rpm

140 = 1400 rpm

145 = 1450 rpm

150 = 1500 rpm

155 = 1550 rpm

160 = 1600 rpm

165 = 1650 rpm

170 = 1700 rpm

175 = 1750 rpm

180 = 1800 rpm

185 = 1850 rpm

#### Digit 20 - Heating Type

A = Steam Coil, LH

B = Hot Water Coil, LH

C = Electric Heat, 1 Stage

F = Hydronic Heat Ctrl Interface

G = Elec. Heat Ctrl Interface, 1 stage

K = Steam Coil Ship Separate, LH

L = Hot Water Coil Ship Separate, LH

M = Steam Coil, RH

N = Hot Water Coil, RH

P = Steam Coil Ship Separate, RH

R = Hot Water Coil Ship Separate, RH

T = Hi-cap. hot water coil, LH

U = Hi-cap. hot water coil LH,

Ship Separate

V = Hi-cap. hot water coil, RH

W = Hi-cap. hot water coil, RH,

Ship Separate

0 = None

#### Digit 21 - Unit Isolators

A = Isopads

B = Spring Isolators

0 = None



# Model Number Description

## SCWG

### Digit 22 - Unit Finish

- 1 = Paint - Executive Beige
- 2 = Protective Coating
- 3 = Protective Coating w/ Finish Coat

### Digit 23

- 0 = None

### Digit 24 - Unit Connection

- 1 = Disconnect Switch
- 2 = Terminal Block
- 3 = Dual Point Power

### Digit 25 - Industrial Options

- A = Protective Coated Evaporator Coil
- B = Silver Solder
- C = Stainless Steel Screws
- D = A and B
- E = A and C
- F = B and C
- G = A, B and C
- 0 = None

### Digit 26 - Drain Pan Type

- A = Galvanized Sloped
- B = Stainless Steel Sloped

### Digit 27 - Waterside Economizer

- A = Mechanical Clean Full Cap. (4-row)
- B = Mechanical Clean Low Cap. (2-row)
- C = Chemical Clean Full Cap. (4-row)
- D = Chemical Clean Low Cap. (2-row)
- E = Mechanical Clean Full Capacity (4-row) Ship Separate
- F = Mechanical Clean Low Capacity (2-row) Ship Separate
- G = Chemical Clean Full Capacity (4-row) Ship Separate
- H = Chemical Clean Low Capacity (2-row) Ship Separate
- 0 = None

### Digit 28 - Ventilation Control

- B = Airside Econ w/Traq™ Damper (Top O/A Inlet)
- C = Airside Econ w/ Standard Dampers (Top O/A Inlet)
- E = Airside Econ w/Traq™ Damper and Comparative Enthalpy (Top O/A Inlet)
- F = Airside Econ w/ Std Dampers and Comparative Enthalpy (Top O/A Inlet)
- G = Traq Damper Ventilation Interface
- H = Ventilation For 2 Pos. Cntrl Interface
- 0 = None

### Digit 29 - Water Piping

- A = Right Hand Condenser Connection
- B = Left Hand Condenser Connection
- C = Right Hand Basic Piping
- D = Left Hand Basic Piping
- E = Right Hand Intermediate Piping
- F = Left Hand Intermediate Piping
- J = Right Hand Basic w/ Flow Switch
- K = Left Hand Basic w/ Flow Switch
- L = Right Hand Intermediate w/ Flow Switch
- M = Left Hand Intermediate w/ Flow Switch
- 0 = None

### Digit 30 - Condenser Tube Type

- A = Standard Condenser Tubes
- B = 90/10 CuNi Condenser Tubes
- 0 = None

### Digit 31 - Compressor Service Valves

- 1 = With Service Valves
- 0 = None

### Digit 32 - Miscellaneous System Control

- 1 = Timeclock
- 2 = Interface for Remote HI
- 3 = Dirty Filter Switch
- 4 = 1 and 2
- 5 = 1 and 3
- 6 = 2 and 3
- 7 = 1, 2, and 3
- 0 = None

### Digit 33 - Control Interface Options

- A = Generic BAS Module (GBAS)
- B = Ventilation Override Module (VOM)
- D = Remote Human Interface (RHI)
- G = GBAS and VOM
- H = GBAS and RHI
- J = VOM and RHI
- M = GBAS, VOM, and RHI
- 0 = None
- 1 = Tracer/LCI-I (COMM5) interface module
- 2 = Tracer/LCI-I and GBAS
- 3 = Tracer/LCI-I and VOM
- 4 = Tracer/LCI-I and RHI
- 5 = Tracer/LCI-I, GBAS and VOM
- 6 = Tracer/LCI-I, GBAS and RHI
- 7 = Tracer/LCI-I, VOM and RHI
- 8 = Tracer/LCI-I, GBAS, VOM and RHI

### Digit 34 - Agency

- T = UL Agency Listing
- 0 = None

### Digit 35 - Filter Type

- 1 = 2-inch Construction Throwaway
- 2 = 2-inch Med Eff. Throwaway

### Digit 36 - Miscellaneous Control Option

- A = Low Entering Air Temp. Protect Device (LEATPD)
- B = High Duct Temp TStat
- C = Plenum High Static Switch
- D = Kit for Heat Mode Output (w/tstat)
- E = A and B
- F = A and C
- G = B and C
- H = A, B, and C
- 0 = None





# Model Number Description

## PSWG

### Self-Contained Ship-With Accessory Model Number Description

<u>P</u>	<u>S</u>	<u>W</u>	<u>G</u>	<u>S</u>	<u>A</u>	<u>1</u>	<u>1</u>	<u>0</u>	<u>JO</u>
<u>1</u>	<u>2</u>	<u>3</u>	<u>4</u>	<u>5</u>	<u>6</u>	<u>7</u>	<u>8</u>	<u>9</u>	<u>10 11</u>

#### Digit 1 - Parts/Accessories

P = Parts/Accessories

#### Digit 2 - Unit Model

S = Self-Contained

#### Digit 3 - Shipment

W = With Unit

#### Digit 4 - Development Sequence

F = Signature Series

G = Modular Series

#### Digit 5 - Sensors and Other Accessories

S = Sensors

#### Digit 6 - Sensors and Thermostats (field installed)

A = BAYSENS077 - Zone Temp Only (CV and VAV)

B = BAYSENS073 - Zone Temp with Timed Override Button (CV and VAV)

C = BAYSENS074 - Zone Temp with Timed Override Button, Setpoint Dial (CV and VAV)

D = BAYSENS023 - Remote Min. Position Potentiometer Control (OA Damper)

E = BAYSENS108 - CV Zone Sensor-dual setpoint, man/auto changeover

F = BAYSENS110 - CV Zone Sensor-dual setpoint, man/auto changeover w, indicator lights

G = BAYSENS019 - CV Programmable Night Setback Sensor

H = BAYSENS021 - VAV Zone Sensor with Indicator Lights

J = BAYSENS020 - VAV Programmable Night Setback Sensor

K = Remote Sensor Kit

L = Outside Air Temperature Sensor Kit

M = Outside Air Humidity Sensor Kit

N = BAYSTAT010 - 2 Heat/2 Cool Thermostat

P = BAYSTAT037A - 2 Heat/2 Cool Programmable Thermostat

0 = None

#### Digit 7 - Mixed Air Temperature Protection Kit (field installed)

1 = Mixed Air Temperature Protection Kit  
0 = None

#### Digit 8 - Carbon Dioxide Sensor (field installed)

1 = Carbon Dioxide Sensor Kit  
0 = None

#### Digit 9 - Future Option

0 = None

#### Digit 10, 11 - Design Sequence

J0 = J Design



# Model Number Description

PSWG

## “After-shipment” Accessory Model Number

**P S A G W N 20 4 \*\* 1 10 0 0 0 1 0 1 0 1 0 0 1 1 0 0 0 0 0 L 1 0 0 7 0 0**  
**1 2 3 4 5 6 7 8 9 10 11 12 13 14 15 16 17 18 19 20 21 22 23 24 25 26 27 28 29 30 31 32 33 34 35 36 37 38 39 40**  
**0 0 0 0 0**  
**41 42 43 44 45**

### Digit 1 - Parts/Accessories

P = Parts/Accessories

### Digit 2 - Unit Model

S = Self-Contained

### Digit 3 - Shipment

A = After Unit

### Digit 4 - Development Sequence

F = Signature Series

G = Modular Series

### Digit 5 - Condenser Medium

W = Water Cooled

R = remote Air Cooled

### Digit 6 - Refrigerant Circuit Configuration

N = Independent (Water-Cooled)

M = Manifolder (Air-Cooled)

### Digits 7, 8 - Unit Nominal Capacity

20 = 20 Tons (Water or Air)

22 = 22 Tons (Water Only)

25 = 25 Tons (Water or Air)

29 = 29 Tons (Water or Air)

30 = 30 Tons (Air Only)

32 = 32 Tons (Water Only)

35 = 35 Tons (Water or Air)

38 = 38 Tons (Water Only)

40 = 40 Tons (Air Only)

42 = 42 Tons (Water Only)

46 = 46 Tons (Water Only)

50 = 50 Tons (Air Only)

52 = 52 Tons (Water Only)

58 = 58 Tons (Water Only)

60 = 60 Tons (Air Only)

65 = 65 Tons (Water Only)

72 = 72 Tons (Water Only)

80 = 80 Tons (Water Only)

### Digit 9 - Unit Voltage

6 = 200 Volt/60 Hz/3 ph

4 = 460 Volt/60 Hz/3 ph

5 = 575 Volt/60 Hz/3 ph

0 = Not Defined

### Digits 10, 11 - Design Sequence

\*\* = Factory Assigned

### Digit 12 - Unit Power Connection

1 = Single Point Power

2 = Dual Point Power

0 = Not Defined

### Digit 13, 14 - Motor HP

05 = 5 HP Motor

07 = 7.5 HP Motor

10 = 10 HP Motor

15 = 15 HP Motor

20 = 20 HP Motor

25 = 25 HP Motor

30 = 30 HP Motor

40 = 40 HP Motor

50 = 50 HP Motor (460V & 575V Only)

0 = Not Defined

### Digit 15 - Exhaust/Comparative Enthalpy Module (Field Installed)

1 = ECEM Kit

0 = None

### Digit 16 - Generic BAS Module

1 = GBAS 0-5 VDC Kit

0 = None

### Digit 17 - Heat Module

1 = Electric Heat Module Kit

2 = Hydronic Heat Module Kit

0 = None

### Digit 18 - Remote Human Interface and IPCB

1 = Remote Human Interface Panel Kit (RHI Only)

2 = Interprocessor Communications Module Kit (IPCB Only)

3 = RHI and IPCB Kit

0 = None

### Digit 19 - LonTalk Communications Interface Kit (LCI)

2 = Tracer/LCI-Comm Interface Kit

0 = None

### Digit 20 - Ventilation Override Module Kit (VOM)

1 = VOM Kit

0 = None

### Digit 21 - Sensors and Thermostats

A = BAYSENS077 - Zone Temp Only (CV and VAV)

B = BAYSENS073 - Zone Temp with Timed Override Button (CV and VAV)

C = BAYSENS074 - Zone Temp with Timed Override Button, Setpoint Dial (CV and VAV)

E = BAYSENS108 - CV Zone Sensor-dual setpoint, man/auto changeover

F = BAYSENS110 - CV Zone Sensor-dual setpoint, man/auto changeover w, indicator lights

G = BAYSENS019 - CV Programmable Night Setback Sensor

H = BAYSENS021 - VAV Zone Sensor with Indicator Lights

J = BAYSENS020 - VAV Programmable Night Setback Sensor

K = Remote Sensor Kit

L = Outside Air Temperature Sensor Kit

M = Outside Air Humidity Sensor Kit

0 = None

### Digit 22 - Low Entering Air Temperature Protection Device

1 = Low Entering Air Temperature Protection Device Kit

0 = None

### Digit 23 - High Duct Temperature Thermostat

1 = High Duct Temp. Thermostat Kit

0 = None

### Digit 24 - Plenum High Static Switch

1 = Plenum High Static Switch Kit

0 = None

### Digits 25 — 45 - Future Use

0 = None

# Installation

## pre-installation considerations

### Receiving and Handling

#### Shipping Package

Commercial self-contained units ship assembled with protective coverings over the coil and discharge openings. Figure I-PC-1 illustrates a typical shipping package.

#### Ship-Separate Accessories

Field-installed sensors ship separately inside the unit's main control panel. Extra filters, sheaves, and belts ship in the unit's fan motor section. Condenser plugs, spring isolators, and isopads ship in the unit's bottom left side.

#### Receiving Checklist

Complete the following checklist immediately after receiving unit shipment to detect possible shipping damage.

- Inspect individual cartons before accepting. Check for rattles, bent carton corners, or other visible indications of shipping damage.
- If a unit appears damaged, inspect it immediately before accepting the shipment. Make specific notations concerning the damage on the freight bill. Do not refuse delivery.
- Inspect the unit for concealed damage before it is stored and as soon as possible after delivery. Report concealed damage to the freight line within the allotted time after delivery. Check with the carrier for their allotted time to submit a claim.**
- Do not move damaged material from the receiving location. It is the receiver's responsibility to provide reasonable evidence that concealed damage did not occur after delivery.
- Do not continue unpacking the shipment if it appears damaged. Retain all internal packing, cartons, and crate. Take photos of damaged material if possible.
- Notify the carrier's terminal of the damage immediately by phone and mail. Request an immediate joint inspection of the damage by the carrier and consignee.
- Notify your Trane representative of the damage and arrange for repair. Have the carrier inspect the damage before making any repairs to the unit.

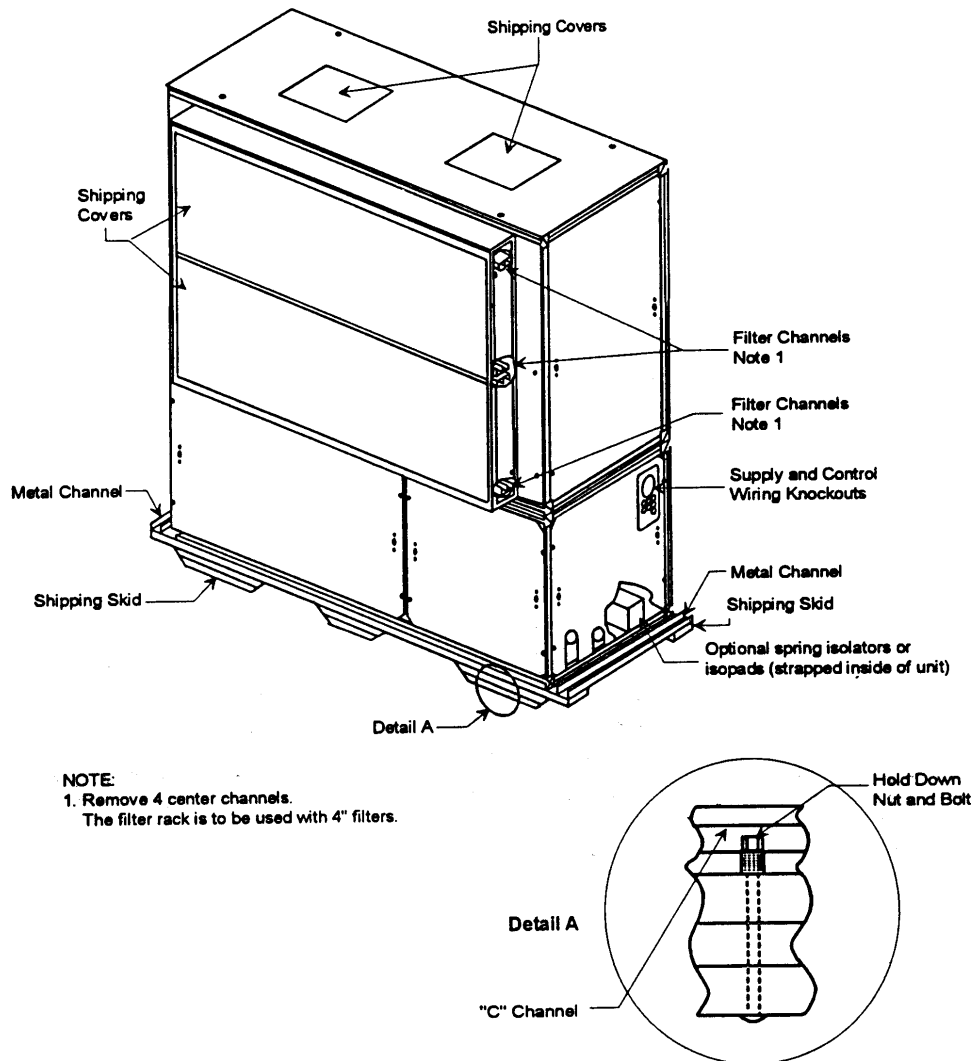

Figure I-PC-1. Typical unit mounted on shipping skid.

# Installation

# pre-installation considerations

## Installation Preparation

***Before installing the unit, perform the following procedures to ensure proper unit operation.***

1. Verify the floor or foundation is level. Shim or repair as necessary. To ensure proper unit operation, install the unit level (zero tolerance) in both horizontal axis. Failure to level the unit properly can result in condensate management problems, such as standing water inside the unit. Standing water and wet surfaces inside units can result in microbial growth (mold) in the drain pan that may cause unpleasant odors and serious health-related indoor air quality problem.
2. Allow minimum recommended clearances for maintenance and routine service. See "Service Access" section on page 13.
3. Position the unit and skid assembly in its final location. If unit shipped split-apart, follow the procedure in the "Split-Apart Unit Assembly" section on page 16 before completing this step. Test lift the unit to determine exact unit balance and stability before hoisting it to the installation location. See Figure I-PC-7 and I-PC-8 on page 15 for typical rigging procedures, including cautions and proper uses of such equipment as fork lifts, spreader bars, and hooks.
4. Remove the skids from under the unit. See the "Rigging and Handling" section on page 14. Refer to the "Skid Removal" section on page 18. If you find internal damage, file a claim immediately to the delivering carrier.
5. Remove the protective shipping covers from the unit. Refer to the "Unit Protective Covers" section on page 35.

---

Note: Unit height and connection locations will change if external vibration isolators are used. The unit may be raised an additional  $5\frac{7}{8}$  inches with spring-type isolators.

---

---

Note: Unit height and connection locations will change if the unit is constructed to be split-a-part in the field. See unit submittal drawings for connection locations.

---

6. Electrical supply power must meet specific balance and voltage requirements, as described in the "Electrical Requirements" section on page 33.
7. Water-cooled units only (model SCWG): The installer must furnish and install a condenser main and standby water pump, cooling tower, pressure gauges and all components for the waterside piping. See the "Water Piping" section on page 30 for general waterside recommendations.
8. Air-cooled units only (model SCRG): These units require field-installation of a remote air-cooled condenser and refrigerant piping. See the "Refrigerant Piping" section on page 32 for general piping recommendations.

# Installation

# pre-installation considerations

## Service Access

### **⚠️ WARNING**

#### **Hazardous Voltage w/Capacitors!**

Disconnect all electric power, including remote disconnects before servicing. Follow proper lockout/tagout procedures to ensure the power cannot be inadvertently energized. For variable frequency drives or other energy storing components provided by Trane or others, refer to the appropriate manufacturer's literature for allowable waiting periods for discharge of capacitors. Verify with an appropriate voltmeter that all capacitors have discharged. Failure to disconnect power and discharge capacitors before servicing could result in death or serious injury.

**Note:** For additional information regarding the safe discharge of capacitors, see PROD-SVB06A-EN or PROD-SVB06A-FR.

See Figure I-PC-2 and Table I-PC-1 for recommended service and code clearances. Access to thermostat unit controls is through a hinged access panel door on the front, lower left of the unit's compressor section.

IntelliPak unit controls access is through a panel on the middle right of the fan section. The panel is secured with an automatic latch and quick-acting fasteners, which require a screwdriver to open.

Removable front unit panels provide access to compressors, fan, motor, inlet guide-vane actuator, and belts.

Removable left side panels give access to drive side, fan bearing, inlet guide-vanes, condensers, and waterside economizer control valve. The compressor, condenser and fan motor access panels are secured with quick-acting fasteners. Access panels for evaporator coils, expansion and water valves, and left fan bearing are sheet metal screws. Access to other components for service requires removal of panels secured with sheet metal screws. During operation, sight glasses are viewable through portholes on the upper right side panel of the fan section.

Variable Frequency Drives are shipped separately and field installed. See page 29 for VFD related dimensions and weights.

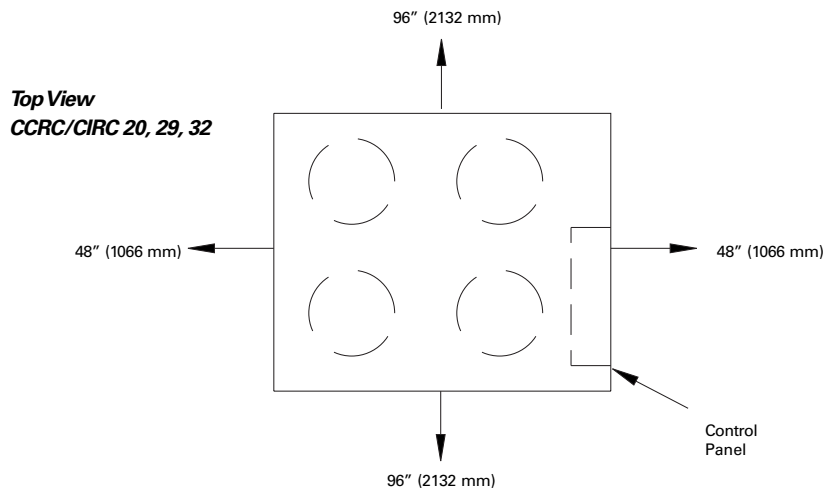

**Table I-PC-1. Service and code clearance requirements**

Side	Distance	Purpose
front	42 in. (20-38 tons)	NEC code requirement
left	18 in.	air-cooled units only
	36 in.	refrigeration & waterside component service
	77 in.	fan shaft removal
right	36 in.	provides uniform airflow
inlet	18 in.	provides uniform airflow

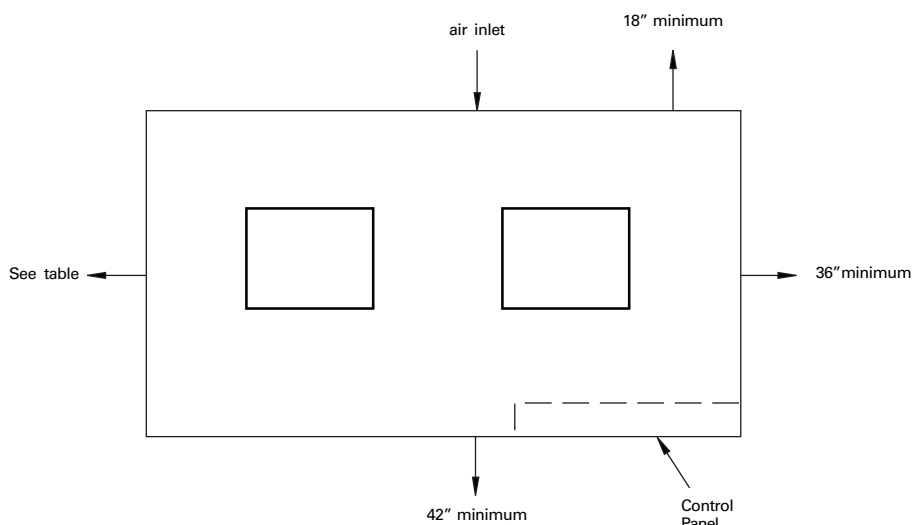

**Figure I-PC-2. Top view of self-contained unit showing recommended service and code clearances**

# Installation

# pre-installation considerations

## Rigging and Unit Handling

### **⚠️ WARNING** Improper Unit Lift!

Test lift unit approximately 24 inches to verify proper center of gravity lift point. To avoid dropping of unit, reposition lifting point if unit is not level. Failure to properly lift unit could result in death or serious injury or possible equipment or property-only damage.

### **⚠️ WARNING** Lifting Equipment Capacity!

Ensure lifting equipment capacity exceeds unit weight by an adequate safety factor to prevent injury, death, or unit damage.

Before lifting the unit or modular component, determine the approximate center of gravity for lifting safety. See Figure I-PC-5 for assembled modular units and Figure I-PC-6 for split-apart units. The center of gravity may vary slightly within the gravity block depending on unit options.

Always test-lift the unit to determine the exact unit balance and stability before hoisting it to the installation location. See Figures I-PC-7 and I-PC-8 for typical rigging procedures and proper rigging equipment usage.

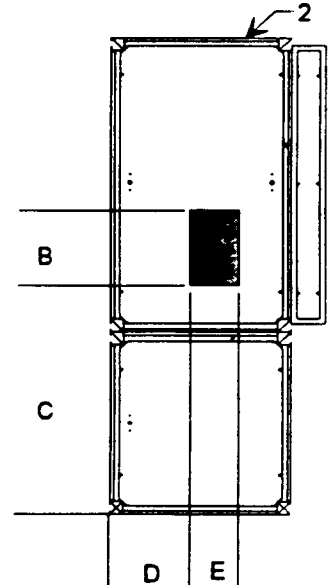
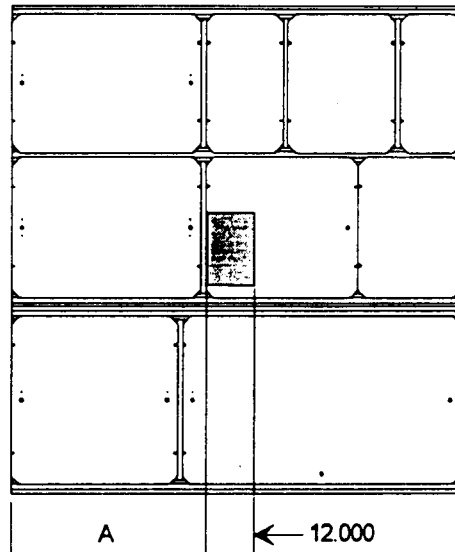
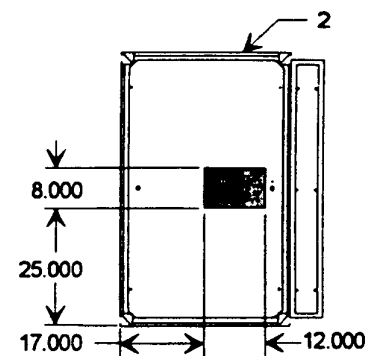
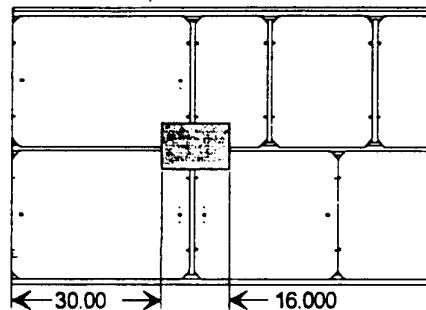

Figure I-PC-5. Assembled unit gravity block location.

Table I-PC-2. Gravity Block Dimensions

Model	A	B	C	D
SCWG	36	14	38	12
SCRG	36	16	40	12

Fan Section Only



Compressor Section Only

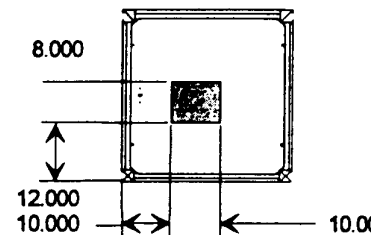
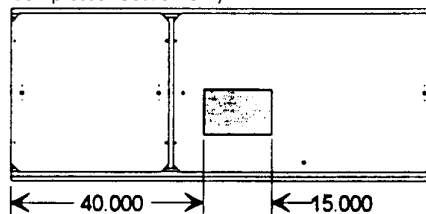

Figure I-PC-6. Split-apart unit gravity block location.

# Installation

## pre-installation considerations

### Unit Handling Procedure

#### NOTICE

Do not use hooks to lift unit or hook into open channels to lift unit. This could cause unit damage.

1. Position rigging sling under wood shipping skid.
2. Use spreader bars to avoid unit damage.
3. When using a forklift, exercise caution to prevent unit damage.
4. Use the standard fork length to lift one end and drag or pull unit while skidding the opposite end.
5. The unit center of gravity will fall within center of gravity block at various locations depending on unit options.
6. Use hooks to lift fan section only. Do not hook into open channels to lift unit.
7. See unit nameplate for unit weight.
8. Do not stack units.

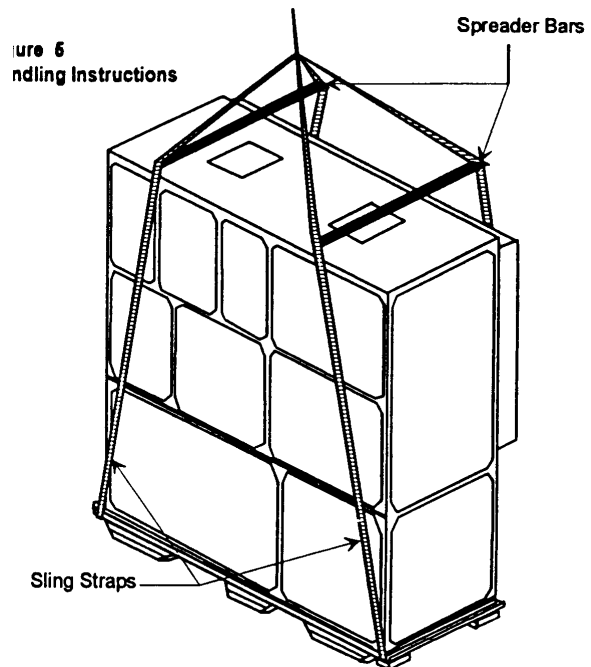

Figure I-PC-7. Assembled modular unit proper rigging.

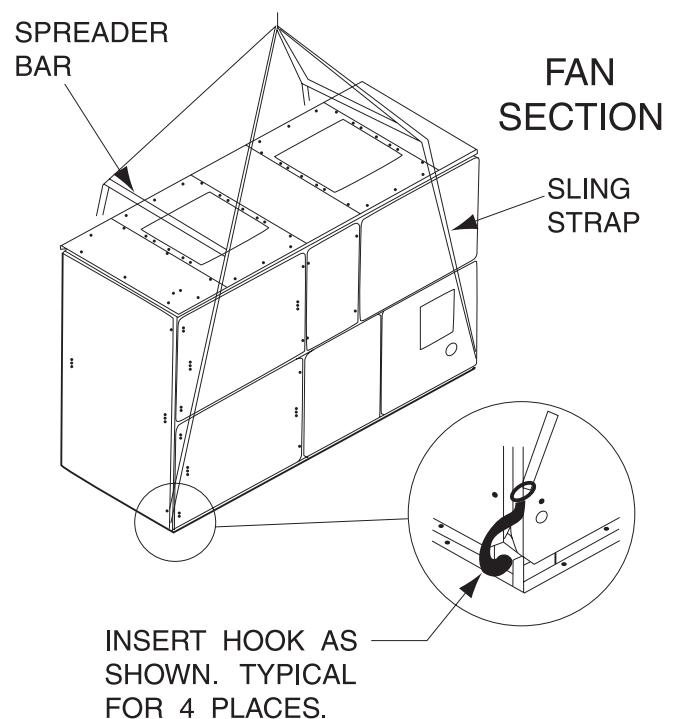
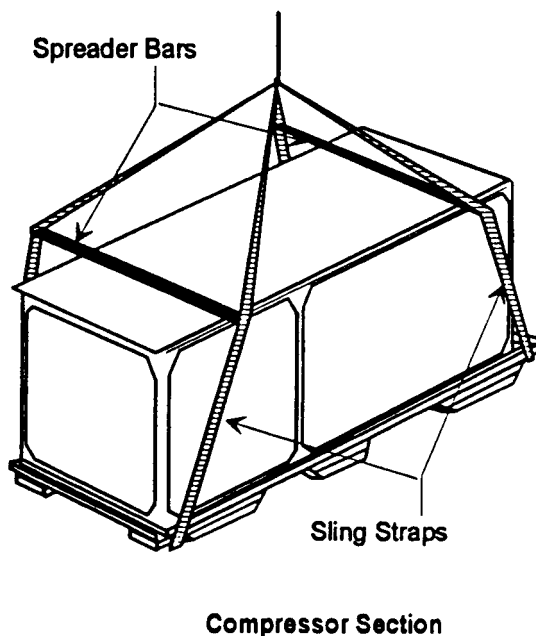

Figure I-PC-8. Split-apart modular unit proper rigging.

# Installation

# pre-installation considerations

## Split-Apart Unit Assembly

1. Ensure the tagging information on the fan section nameplate matches that on the compressor nameplate.
2. Remove the connector brackets holding the the sheet metal shipping cover on compressor section. Retain brackets and screws.
3. Remove shipping cover from the compressor section and verify the ship-with package contains:
  - suction and discharge line couplings
  - insulation
  - sheet metal screws
4. Lift fan section onto the compressor section using the rigging method in Figure I-PC-8 on page 13.
5. Remove skid from the fan section, placing the fan section onto the compressor section. Reference Figure I-PC-9.
6. Install the connection brackets with the sheet metal screws (referenced in step 2) on all sides of the unit. Reference Detail "A" in Figure I-PC-9.
7. Remove the unit panels labeled RU and RL in Figure I-PC-10 on page 17. To remove panels, first remove the four shipping screws located in the corner of each panel. Next, turn the remaining  $\frac{1}{4}$  turn fasteners to the unlatch position. The panel is supported by a "lip" channel. So, lift the panel up and off the unit to remove it. See Detail "A" in Figure I-PC-9.
8. Connect the drain hose to the drainpan outlet fitting and secure it with the drain hose clamp provided.
9. Circulate nitrogen throughout refrigerant circuits.
10. Unbrazed and remove the caps on the discharge and suction lines in both the compressor and fan sections.
11. Install and braze discharge and suction line couplings.

12. Insulate discharge and suction lines with the insulation provided.
13. Remove panel FLR and open the bottom control panel door, FLL. Pull the fan motor leads (coiled in the fan section) through the knockout in the bottom of the fan section to the control panel. Ensure that the bushing is installed in the hole to prevent the wires from chafing. Refer to the unit wiring diagrams to connect the fan motor leads properly and ensure correct phase sequencing.

### IntelliPak Units(UCM) Only

14. Remove panels FML, FMM, and FMR.
15. Pull the circular plug connector (CPC) from the compressor section through the knockouts into the fan section. Install the bushings (provided on the wiring harnesses) in the knockouts.
16. Using the CPC wiring diagram, connect the male CPC to the female CPC in the top control panel.
17. If the unit has the mixed air temperature option, route the capillary tube on back of the filter rack.

### Units with Thermostat Only

18. Remove panel FMR. See Note 1 on Figure I-PC-10.
19. Pull frost protection wires from the bottom control panel through knockouts in bottom of fan section. Route wires to the appropriate frost protection switches on the evaporator coil. Reference the unit wiring diagrams to connect frost protection wiring connectors.

### Air-Cooled Units Only:

20. Route the refrigerant circuit wires for circuits 1 and 2 from the bottom control panel through the knockouts to the solenoid valves. The solenoid valves are located in the liquid refrigerant lines on the right-hand side of the unit. Refer to the unit wiring diagrams to make splice connections.



# Installation

## pre-installation considerations

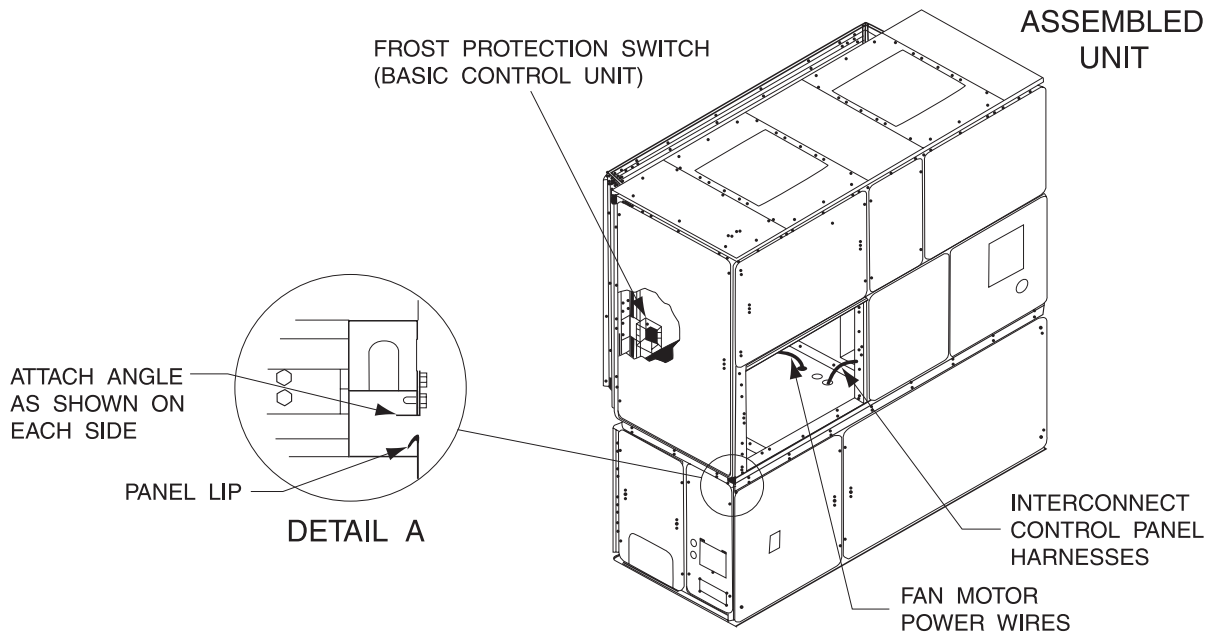

**Figure I-PC-9 How to assemble the split apart modular unit**

**NOTES:**

- 1 PANEL FMM IS ONLY USED ON UNITS WITH INTELLIPAK CONTROL. UNITS W/BASIC CONTROLS HAVE ONE PANEL THAT REPLACES FMM & FMR.

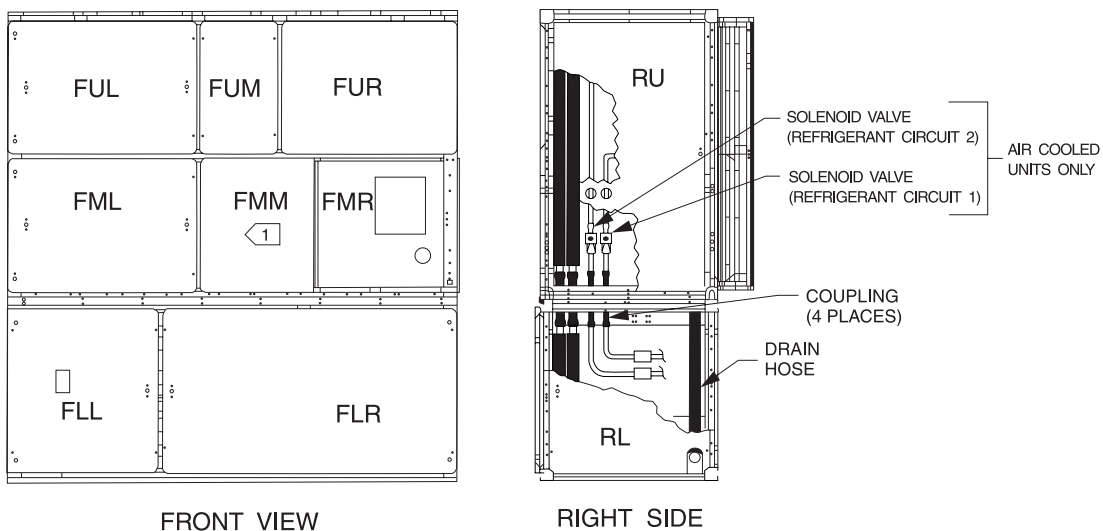

**Figure I-PC-10 Modular unit panel description and internal connections**

# Installation

# pre-installation considerations

## Skid Removal

The unit ships on skids to provide forklift locations from the front or rear. The skid allows easy maneuverability of the unit during storage and transportation. Remove the skids before placing the unit in its permanent location.

Remove the skids using a forklift or jack. Lift one end of the unit off of the skids. See Figure I-PC-5 and I-PC-6 for unit gravity block location. Slide the skids out and lower the unit at the installation location.

Note: External isolation is not necessary since units are internally isolated. Consult a vibration specialist before "double-isolating" the unit.

## External Unit Isolation

If your job requires external vibration isolation, two options are available: isopads or spring-type isolators. Isopads should be placed under the unit at locations indicated on the factory-provided isolator sheet.

Set the spring-type isolators (Figure I-PC-9) in position after the unit is removed from skids before making electrical, piping, or duct connections. All units require a minimum of four isolators per unit. But some may require six isolators, depending upon unit options.

Note: Trane strongly recommends you consult a vibration specialist before double-isolating the unit. Double isolation is not recommended.

If you decide to externally isolate the unit, use spring-flex, type CP isolators. The spring number is marked on the outer housing. See Figure I-PC-9.

### To install external isolators, complete the following procedure.

1. Locate the isolators under unit base at the locations indicated on the factory-provided isolator placement sheet. Lift one end of the unit at a time to position isolators to the floor, using anchor bolts.
2. Level the unit by adjusting isolator heights. Unit weight may cause the upper housing to rest on the lower housing of the spring isolators. The isolator clearance shown in the side

view of Figure I-PC-9, must be  $\frac{1}{4}$  -  $\frac{1}{2}$  inches. To increase the clearance, lift the unit off the isolator and turn the leveling bolt counterclockwise. Recheck the unit level and the housing clearances. Maximum allowable difference between isolator heights is  $\frac{1}{4}$  inch. Shim as required under the isolators.

Note: The compressors and fan assembly are internally isolated on most units. Due to this, the addition of external isolation devices (spring mounting isolators) is at the discretion of the building or HVAC system designer.

## Pre-Installation Checklist

Complete the following checklist before beginning unit installation.

- Verify the unit size and tagging with the unit nameplate.
- Make certain the floor or foundation is level, solid, and sufficient to support the unit and accessory weights. Level or repair the floor before positioning the unit if necessary.
- Allow minimum recommended clearances for routine maintenance and service. Refer to unit submittals for dimensions.
- Allow three fan diameters above the unit for the discharge ductwork. Return air enters the rear of the unit and conditioned supply air discharges through the top.
- Electrical connection knockouts are on the top, left side of the unit.
- Allow adequate space for piping access and panel removal. Condenser water piping, refrigerant piping, and condensate drain connections are on the lower left end panel.
- Electrical supply power must meet specific balance and voltage requirements as described in the "Electrical Requirements" section.
- Water-cooled units only: The installer is responsible for providing a condenser main, standby water pump, cooling tower, pressure gauges, strainers, and all components for waterside piping. See the "Water Piping" section for general waterside recommendations.
- Air-cooled units only: The installer is responsible for providing and installing the remote air-cooled condenser and refrigerant piping, including filter driers.

Note: Unit height and connection locations will change if using vibration isolators. The unit height may increase up to  $5\frac{7}{8}$ " with spring type isolators.

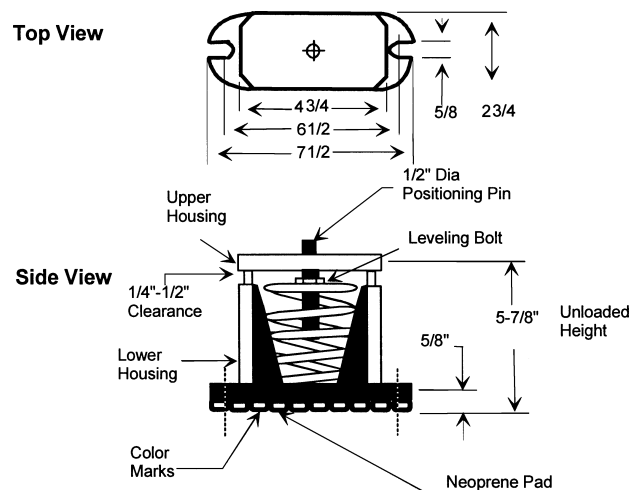

Figure I-PC-9. Optional spring isolator dimensional data.





# Dimensions & Weights

# SCRG / SIRG

## SCRG/SIRG Dimensions, in.

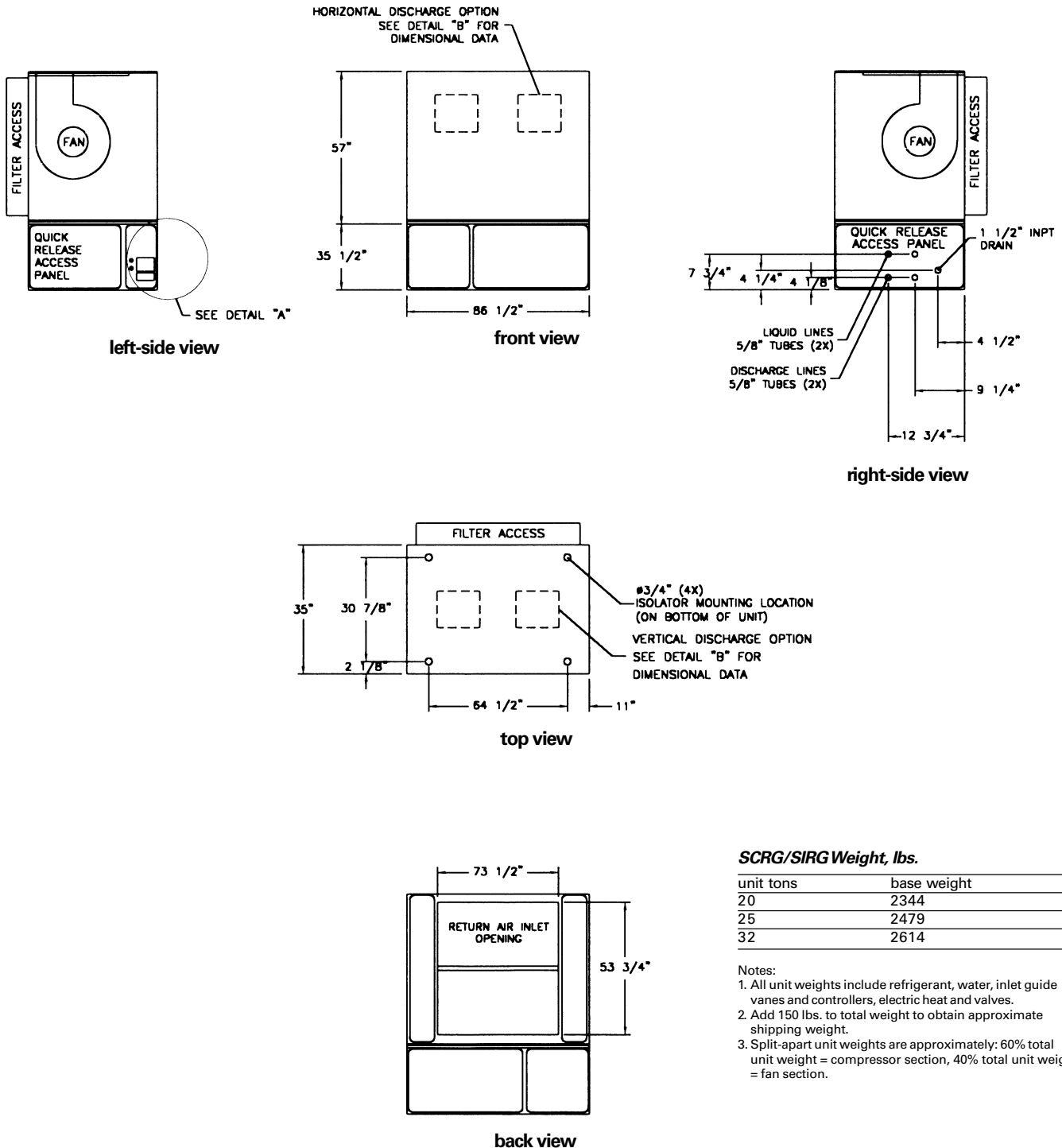

### SCRG/SIRG Weight, lbs.

unit tons	base weight
20	2344
25	2479
32	2614

#### Notes:

- All unit weights include refrigerant, water, inlet guide vanes and controllers, electric heat and valves.
- Add 150 lbs. to total weight to obtain approximate shipping weight.
- Split-apart unit weights are approximately: 60% total unit weight = compressor section, 40% total unit weight = fan section.

# Dimensions & Weights

**SCRG/SIRG/SCWG/SIWG Detail "A"**  
Electrical Connections, in.

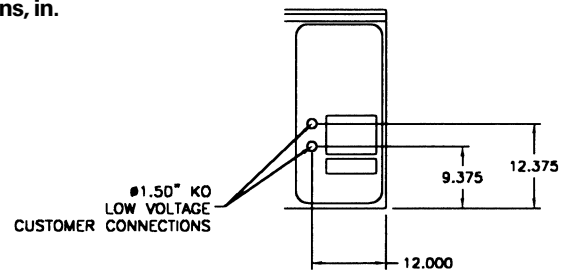

**Detail "B" Discharge Options , in.**

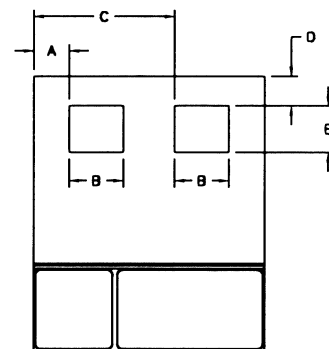

**front view**  
shown with horizontal discharge option

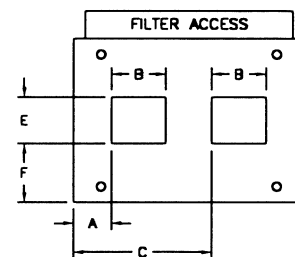

**TOP VIEW**  
(SHOWN WITH VERTICAL DISCHARGE OPTION)

**top view**  
shown with vertical discharge option

**Detail Dimensions, in.**

model	A	B	C	D	E	F
SCWG/SCRG 20	20	10 <sup>3</sup> / <sub>4</sub>	58 <sup>1</sup> / <sub>2</sub>	5 <sup>1</sup> / <sub>8</sub>	13 <sup>1</sup> / <sub>4</sub>	11 <sup>1</sup> / <sub>2</sub>
SCWG/SCRG 25	19 <sup>1</sup> / <sub>4</sub>	12 <sup>1</sup> / <sub>4</sub>	57 <sup>5</sup> / <sub>8</sub>	5 <sup>1</sup> / <sub>8</sub>	13 <sup>1</sup> / <sub>4</sub>	11 <sup>1</sup> / <sub>2</sub>
SCWG 30 - 35/SCRG 32		18	14 <sup>5</sup> / <sub>8</sub>	56 <sup>1</sup> / <sub>2</sub>	5 <sup>1</sup> / <sub>8</sub>	13 <sup>1</sup> / <sub>4</sub>
						11 <sup>1</sup> / <sub>2</sub>



# Dimensions & Weights

# CCRC / CIRC

## CCRC/CIRC – Air-Cooled Condenser

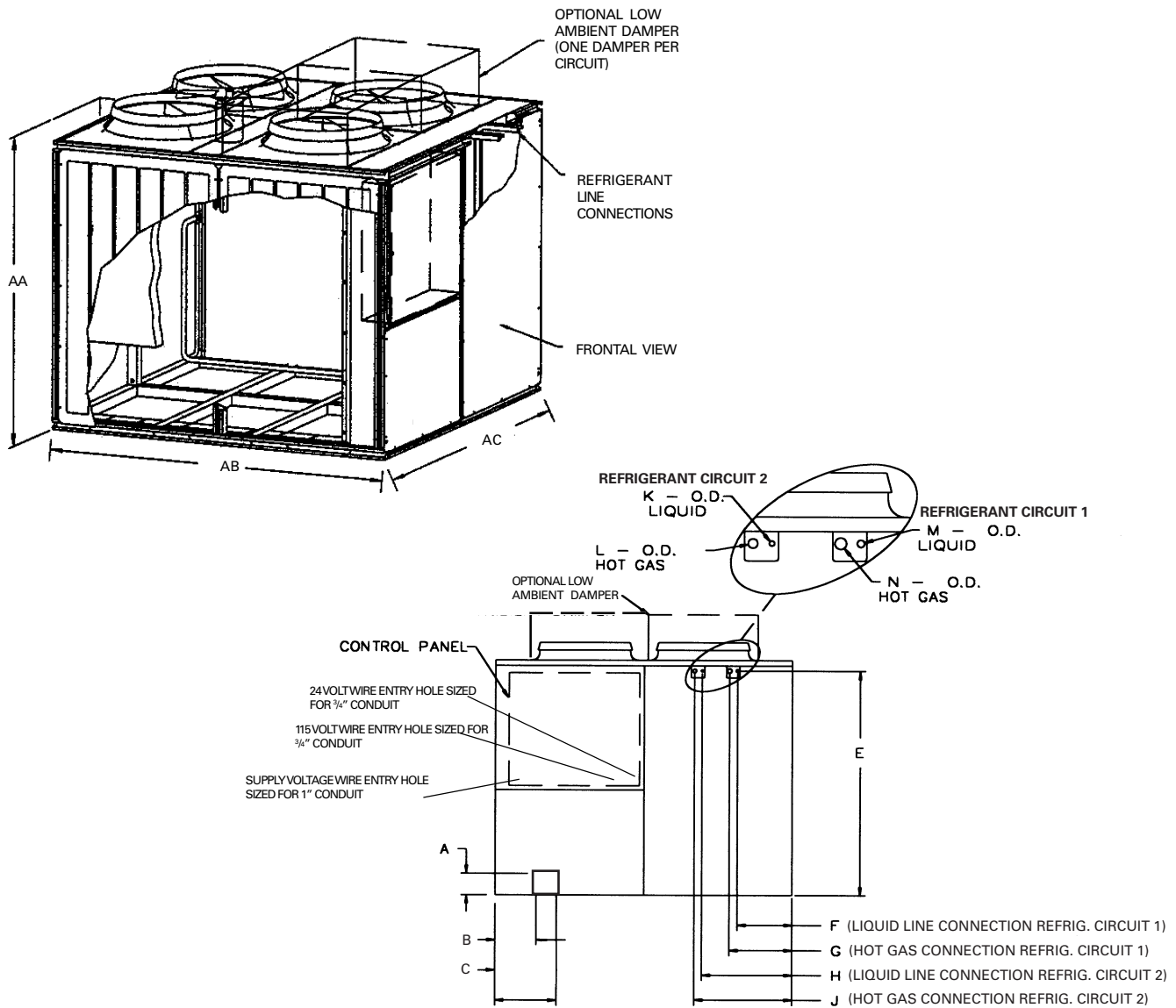

**CCRC/CIRC Air-cooled condenser dimensions & weight, in-lbs.**

model	AA	AB	AC	shipping weight	operating weight
CCRC/CIRC 20	70 1/8	88	88	2030	1906
CCRC/CIRC 29	70 1/8	88	88	2084	1960
CCRC/CIRC 32	70 1/8	88	88	2138	2014

**CCRC/CIRC Electrical connections, in.**

model	A	B	C
CCRC/CIRC 20-32	4 1/2	10 1/2	17 1/2

**CCRC/CIRC Refrigerant connections, in.**

model	E	F	G	H	J	K	L	M	N
CCRC/CIRC 20-32	66 7/8	14 3/8	18 1/2	24 3/4	29	5/8	1 1/8	5/8	1 1/8

# Dimensions & Weights

## Hot Water Coil

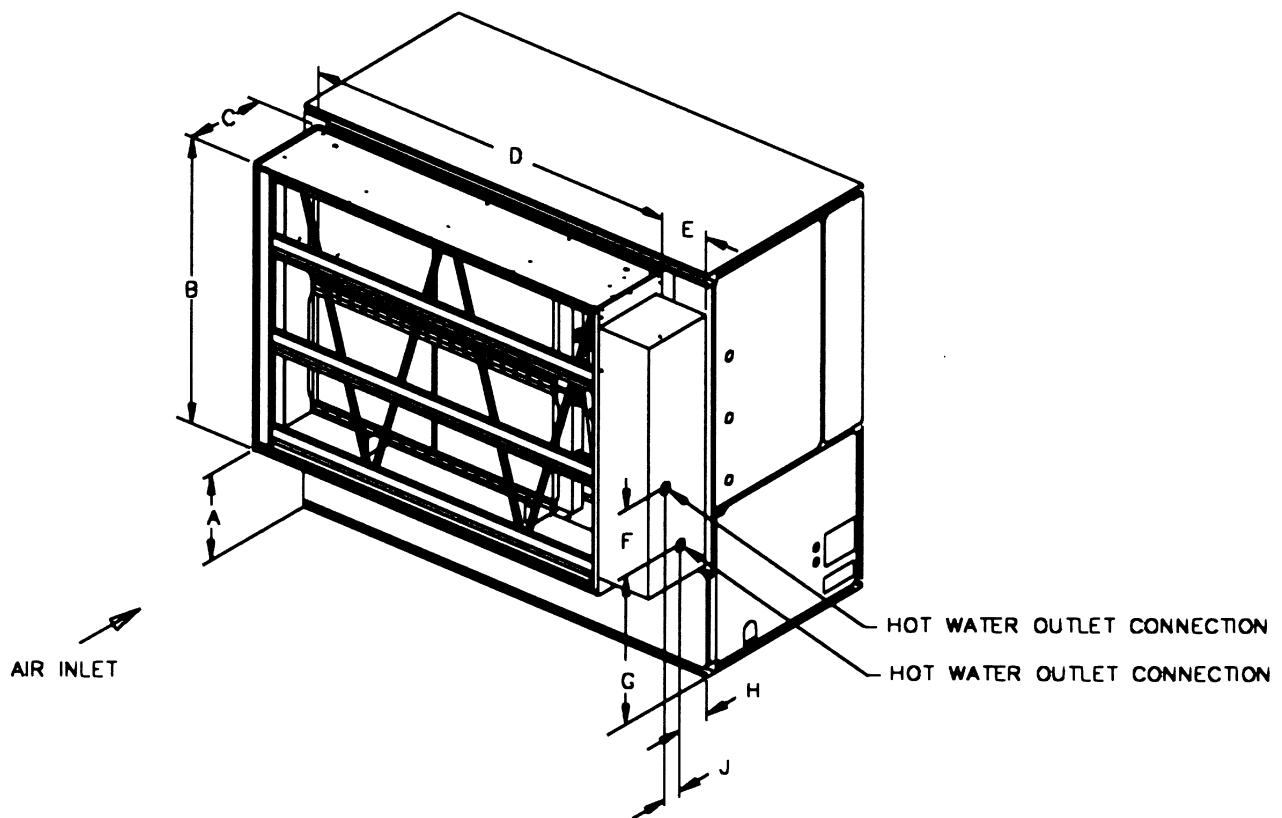

**Hot water coil dimensions & weight, in-lbs.**

unit size	A	B	C	D	E	F	G	H	J	weight
20 - 35 tons	37 1/4	53 3/4	16 5/8	73 1/2	14 7/8	16 1/4	43 1/4	5 5/8	7 3/4	460

# Dimensions & Weights

## Steam Coil

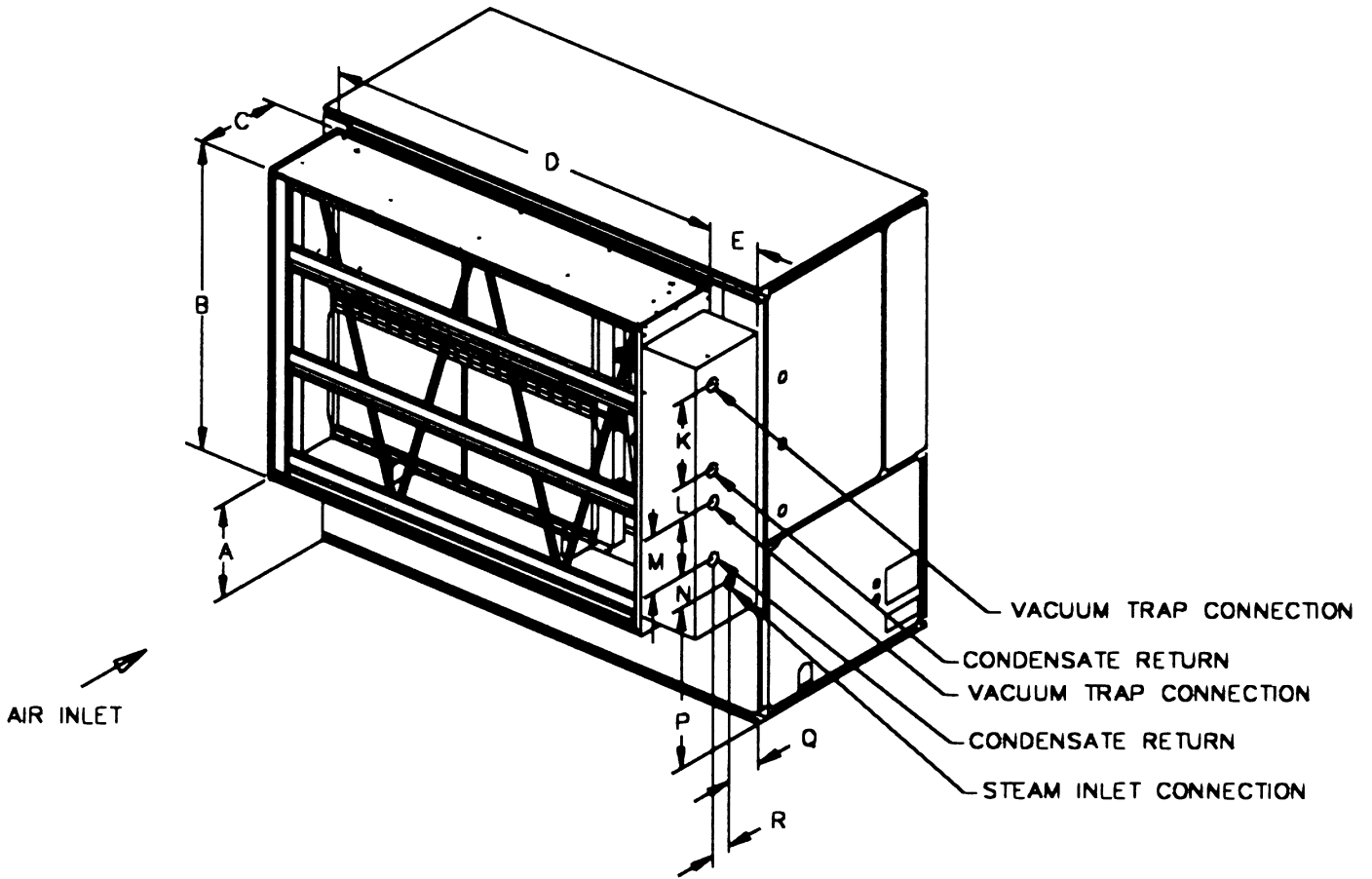

*Steam coil dimensions, in-lbs.*

unit size	A	B	C	D	E	K	L	M	N	P	Q	R	weight
20 - 35 tons	37 1/4	53 3/4	16 5/8	73 1/2	10 7/8	22 1/2	3 3/8	15 7/8	1	41	9 3/8	4 3/8	460



# Dimensions & Weights

## Electric Heat Coil

*Electric heat coil dimensions & weight, in-lbs.*

unit size	A	B	C	D	weight
20 tons	70 1/4	4 7/8	11 1/2	19	460
25 tons	70 1/4	4 1/8	11 1/2	19	460
30 - 35 tons	70 1/4	2 7/8	11 1/2	19	460

Note: Coil box height is 8 in.

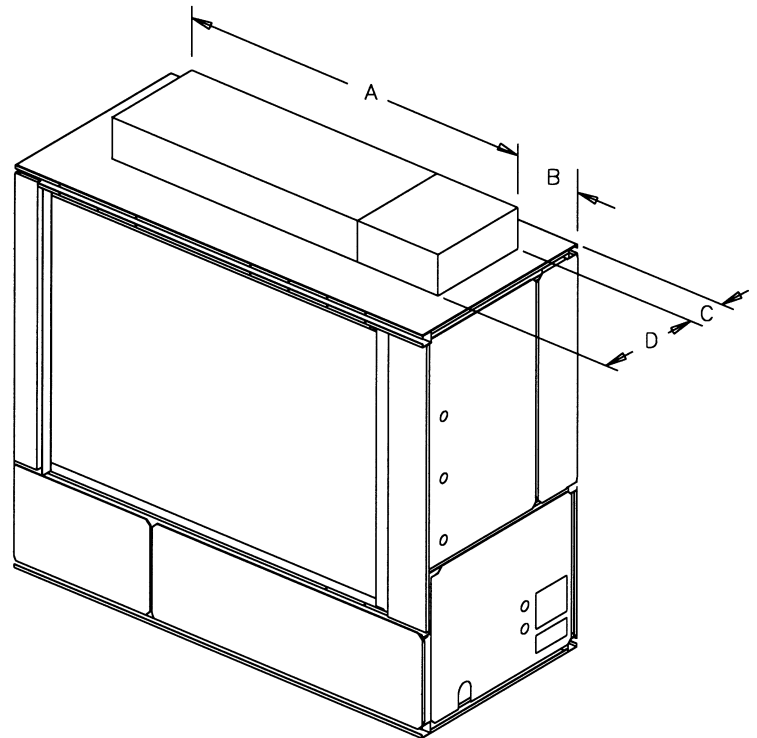

## Flexible Horizontal Discharge Plenum

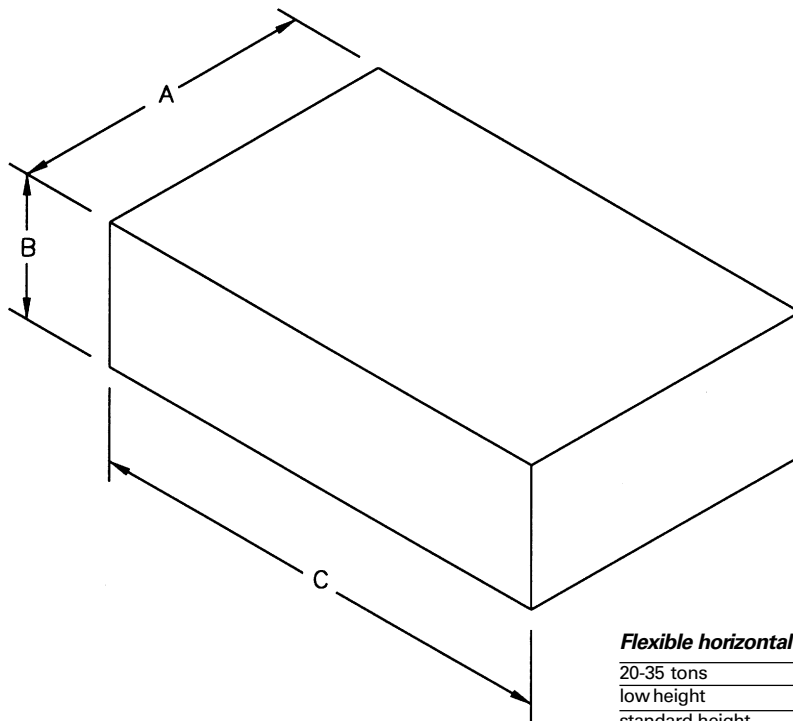

*Flexible horizontal discharge plenum dimensions & weights, in-lbs.*

20-35 tons	A	B	C	weight
low height	35	17 1/4	86 1/2	262
standard height	35	25 1/4	86 1/2	352

# Dimensions & Weights

---

## Waterside Economizer

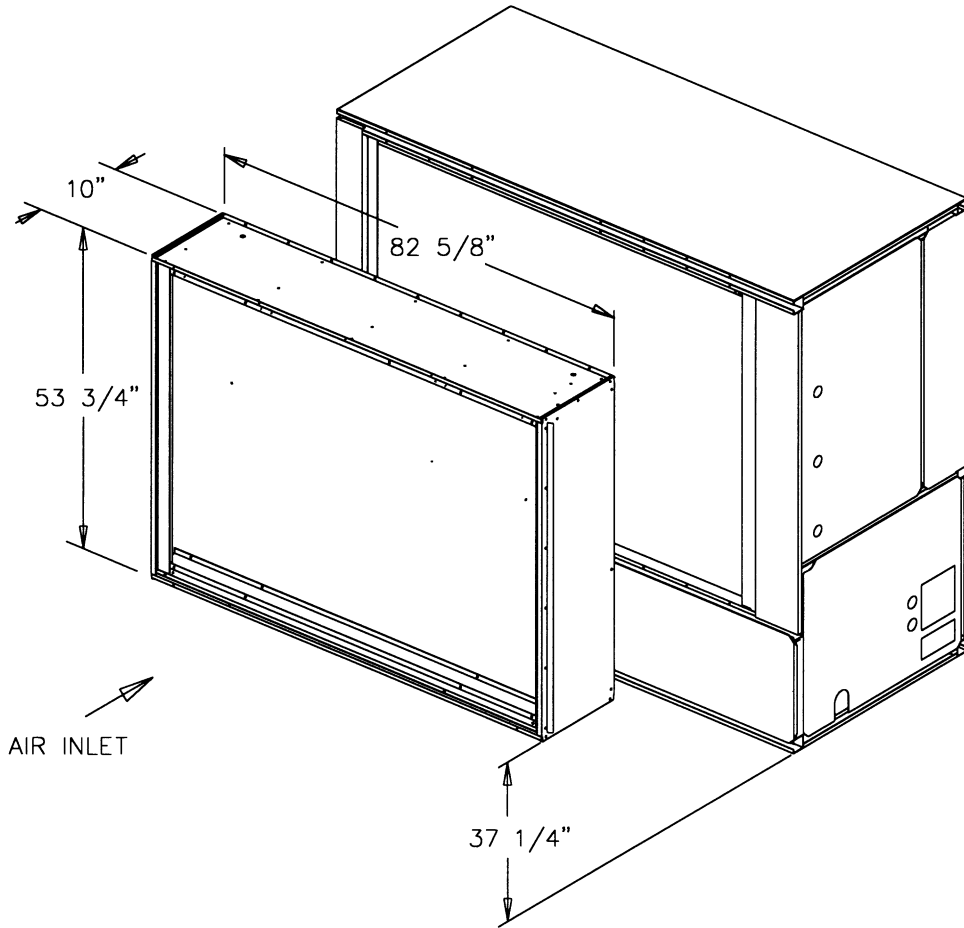

***Waterside economizer weight, in-lbs.***

unit size	weight	
	2-row	4-row
20 - 35 tons	488	584

# Dimensions & Weights

# Airside Economizer

## Airside Economizer

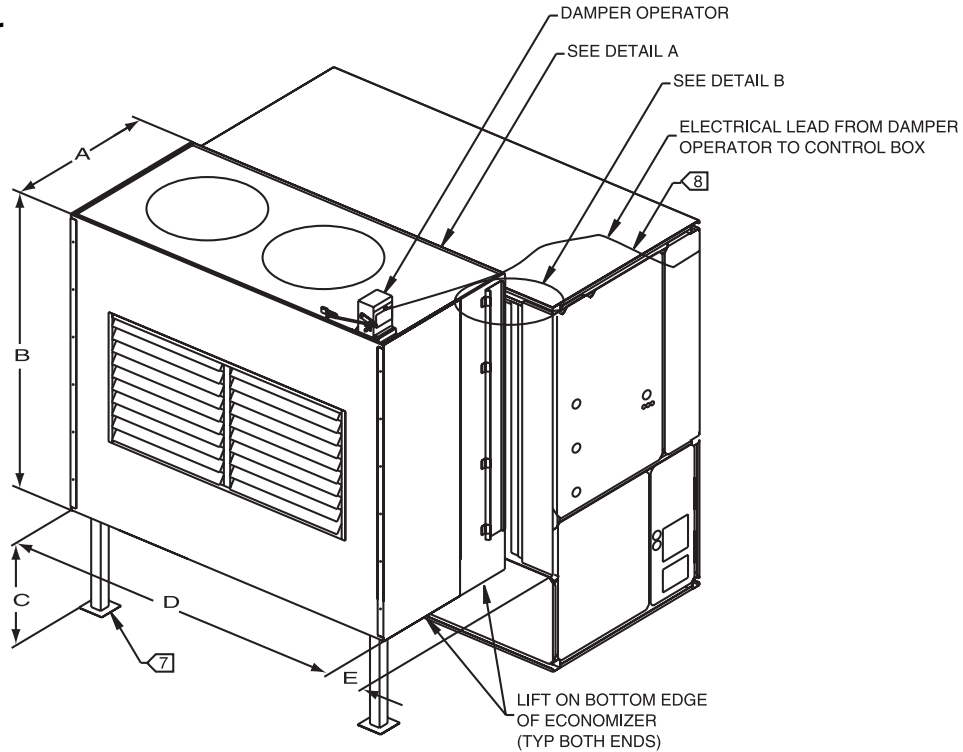

**Airside economizer dimensions & weight, in-lbs.**

unit size	A	B	C	D	E	F (1)	F (2)	G (1)	G (2)	H (1)	H (2)	J	K	L	M	weight
SCWG/SIWG 20, 25 SCRG/SIRG 20	36	65 5/8	37	74 1/4	6 1/8	56 1/2	49 3/4	23 1/4	20 1/2	5 5/8	7	20 1/2	17 1/8	12	49 3/4	273
SCWG/SIWG 30, 35 SCRG/SIRG 25, 32	36	65 5/8	37	74 1/4	6 1/8	61 3/8	62 3/4	28 1/8	20 1/2	3 1/4	7	20 1/2	17 1/8	5 1/2	62 3/4	273

### Detail "A"

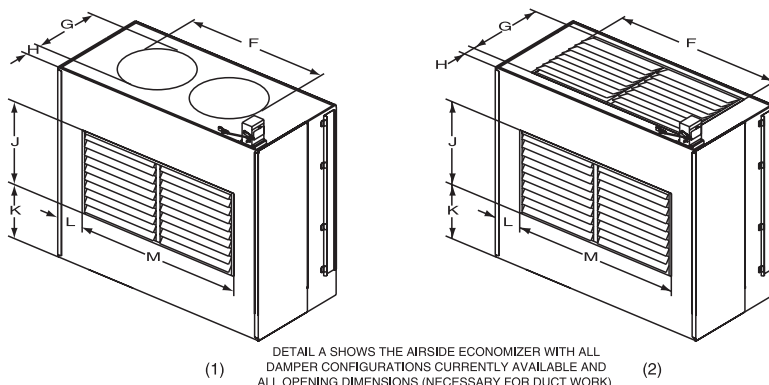

### Detail "B"

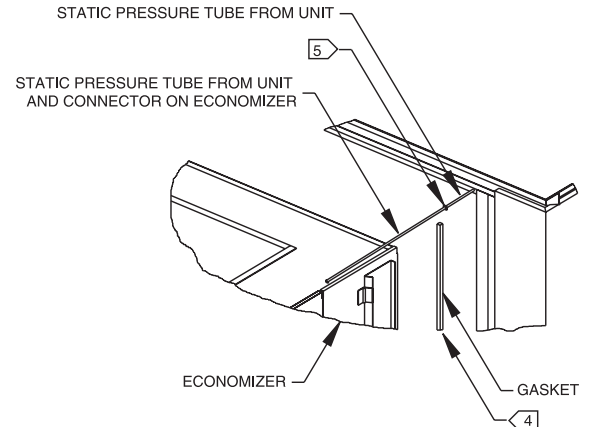



# Dimensions & Weights

## VFD

### Variable Frequency Drive Option (VFD)

#### ⚠ WARNING

#### Control and Line Voltage!

Control and line voltage wiring from the VFD to the unit must be in accordance with all local and National Electric Codes. Do not touch circuit components until main power has been turned off and "charge" lamp is extinguished. The capacitors are still charged and could result in death or serious injury.

#### ⚠ WARNING

#### Hazardous Voltage w/Capacitors!

Disconnect all electric power, including remote disconnects before servicing. Follow proper lockout/tagout procedures to ensure the power cannot be inadvertently energized. For variable frequency drives or other energy storing components provided by Trane or others, refer to the appropriate manufacturer's literature for allowable waiting periods for discharge of capacitors. Verify with an appropriate voltmeter that all capacitors have discharged. Failure to disconnect power and discharge capacitors before servicing could result in death or serious injury.

Note: For additional information regarding the safe discharge of capacitors, see PROD-SVB06A-EN or PROD-SVB06A-FR.

#### NOTICE

#### Use Copper Conductors Only!

Unit terminals are not designed to accept other types of conductors. Failure to use copper conductors may result in equipment damage.

The variable frequency drive (VFD) option can only be used with IntelliPak units. The VFD and VFD w/bypass is available from 5 to 25 hp and is a Trane TR1. All VFD's are pre-configured and run tested at the factory prior to shipping. The VFD is wall mounted.

#### Mounting Requirements

Proper location of the VFD is important to achieve proper performance and normal operating life. Installation must be in an area where it will be protected from:

- Direct sunlight, rain or moisture.
- Corrosive gases or liquids.
- Vibration, airborne dust, or metallic particles.

For effective cooling as well as proper maintenance, install the VFD vertically to the ground using four mounting screws.

There **must** be a **minimum** eight inch clearance above and below the VFD. A minimum two inch clearance is required on each side.

Also, allow enough clearance for opening the VFD cabinet door. This will ensure sufficient air space for cooling.

Refer to the "Dimensions and Weights" section beginning on page 19 for VFD dimensions and weights.

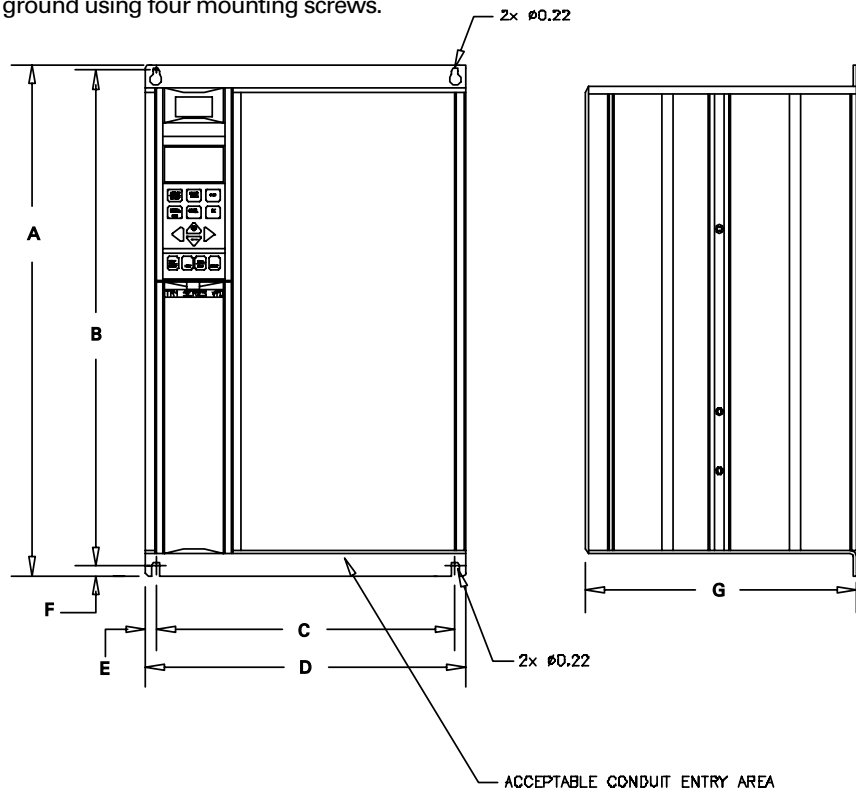

VFD dimensions, in.

voltage	hp	A	B	C	D	E	F	G
460	7.5	15.55	15.12	7.87	8.66	0.39	0.24	7.87
	10							
208	7.5	22.05	21.26	7.87	9.53	0.83	0.30	10.24
	10							
460	15	27.56	26.77	10.63	12.13	0.83	0.30	11.05
	20							
	30							
	40							
208	30	31.50	30.71	10.63	12.13	0.75	0.30	11.65
	50							
460	50	31.49	30.71	10.63	14.57	1.97	-	13.19
	60							

# Dimensions & Weights

## VFD

### Electrical Installation Procedure

Refer to the *National Electric Code*, section 310-16 for sizing wires 4B - 9B. All other control wires should be twisted shielded or twisted pair shielded, 20 - 14 AWG, with lead length not to exceed 164 feet. When using shielded wire, the shield sheath **must** be connected at the VFD only. The connection on units with VFD is J13-S. The connection on units with VFD/bypass is ITBI-10.

### Variable Frequency Drive with Bypass

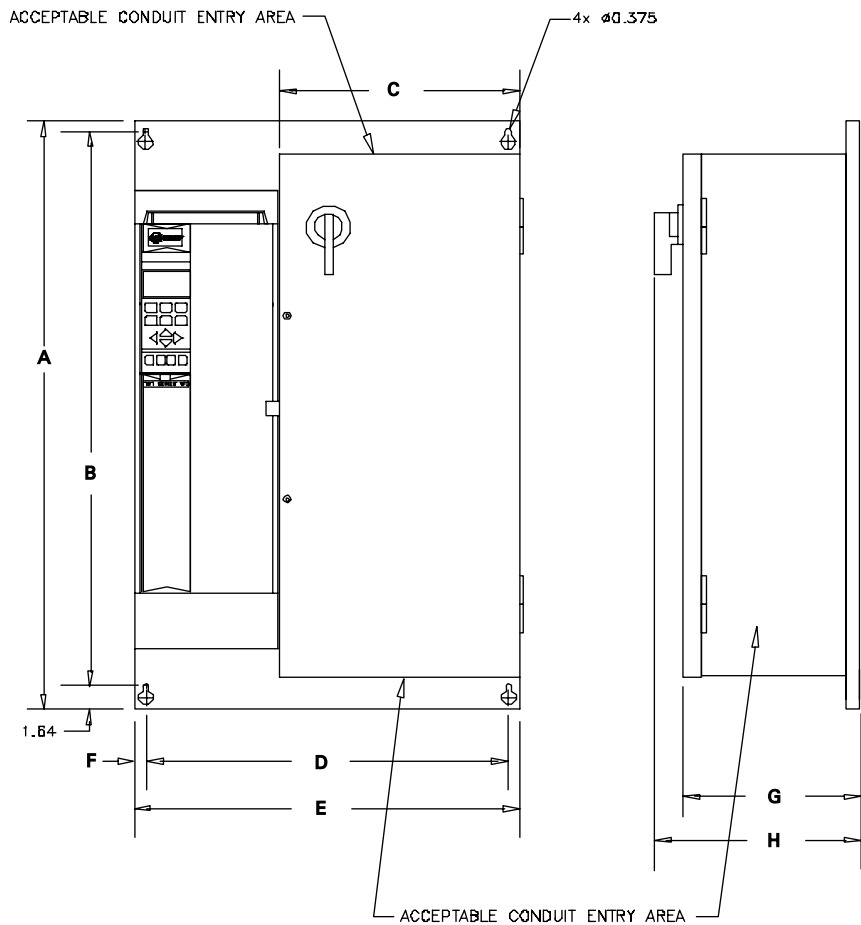

**VFD with bypass dimensions, in.**

voltage	hp	A	B	C	D	E	F	G	H
460	7.5	30.40	28.03	16.14	23.35	24.85	0.75	8.59	10.63
	10								
208	7.5	41.28	38.89	16.14	24.00	25.5	0.75	10.95	12.99
	10								
	15								
460	15	50.81	48.35	21.36	31.61	33.41	0.90	12.36	14.41
	20								
	25								

# Mechanical Specifications

## Duct Connections

### **⚠️ WARNING** Hazardous Voltage w/Capacitors!

Disconnect all electric power, including remote disconnects before servicing. Follow proper lockout/tagout procedures to ensure the power cannot be inadvertently energized. For variable frequency drives or other energy storing components provided by Trane or others, refer to the appropriate manufacturer's literature for allowable waiting periods for discharge of capacitors. Verify with an appropriate voltmeter that all capacitors have discharged. Failure to disconnect power and discharge capacitors before servicing could result in death or serious injury.

**Note:** For additional information regarding the safe discharge of capacitors, see PROD-SVB06A-EN or PROD-SVB06A-FR.

Return air enters the rear of the unit and conditioned supply air discharges through the top. Attach supply air ductwork directly to the unit's top panel, around the fan discharge opening. A duct collar is not provided.

**Note:** Units equipped with the flexible horizontal discharge plenum option may include a duct collar when holes are factory cut. If discharge openings are field-cut, refer to the "Plenum Installation" section.

Install all air ducts according to the National Fire Protection Association standards for the "Installation of Air Conditioning and Ventilation Systems other than Residence Type (NFPA 90A) and Residence Type Warm Air Heating and Air Conditioning Systems (NFPA 90B).

Make duct connections to the unit with a flexible material such as heavy canvas. If a fire hazard exists, Trane recommends using Flexweave 1000, type FW30 or equivalent canvas. Use **three inches** for the return duct and **three inches** for the discharge duct. Keep the material loose to absorb fan vibration.

**Note:** The compressors and fan assembly are internally isolated. Therefore, external isolation devices (spring mounting isolators) are at the discretion of a vibration specialist consulted by the building or HVAC system designer.

Run the ductwork straight from the opening for a minimum of three fan diameters. See Figure I-MR-1. Extend remaining ductwork as far as possible without changing size or direction. Do not make abrupt turns or transitions near the unit due to increased noise and excessive static losses. Use elbows with splitters or turning vanes to minimize static losses.

Poorly constructed turning vanes may cause airflow generated noise. Align the fan outlet properly with the ductwork to decrease noise levels in the duct and to increase fan performance. To complete trunk ductwork to the VAV terminal units, refer to the VAV box manuals for specific requirements. Check total external static pressures against fan characteristics to be sure the required airflow is available throughout the ductwork.

To achieve maximum acoustical performance, minimize the duct static pressure setpoint.

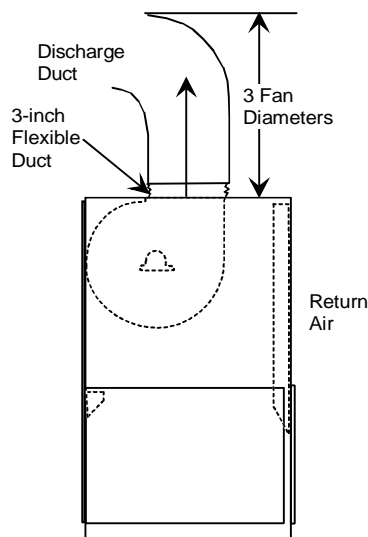

**Figure I-MR-1. Duct connection recommendations**

## Water Piping

### **⚠️ WARNING** High Pressure Water!

**Provide relief valves on system water piping to prevent instantaneous release of high pressure water. Failure to provide relief valves could result in death or serious injury or water pump damage or unit failure.**

### Condenser Connections

Condenser water piping knockouts are in the lower left end panel. If necessary, remove insulation to gain access. All field installed piping must conform to applicable local, state, and federal codes. To complete condenser water connections follow the procedure below.

**Note:** Four condenser waterline drain plugs ship in a bag in the unit's left end. The installer must field install these four plugs using pipe thread sealer. An additional plug is provided for units with a waterside economizer.

1. Attach the water supply line to the inlet connection, and the return line to the outlet connection. Entering and leaving water connections for all condensers are factory manifolded and require only single connections for entering and leaving water. If the unit has a waterside economizer and/or control valves, the factory pipes between these components.
2. If using a cooling tower, refer to Figure I-MR-2 for a typical piping circuit from the unit.
3. Ensure the water pressure to the unit does not exceed 400 psig.

**Note:** To prevent water pump damage, design system piping to provide relief when using energy saving waterside economizer valves.

# Mechanical Specifications

## Condensate Drain Connections

The condensate drain is internally trapped. Condensate drain connections are on the unit's left side. Connect condensate drain piping to the 1 1/4" NPT female fitting, using at least 7/8" OD copper or 3/4" OD iron pipe. Pitch the condensate line downward a minimum of 1/2" for each 10' of horizontal run, away from the unit. Be sure to install the condensate drain "P" trap drain plug. Before starting the unit, fill the trap with water to prevent negative pressure in the fan section from impeding condensate flow. To facilitate drain pipe cleaning, install plugged tees in place of 90° elbows.

## General Waterside Recommendations: Cooling Towers

Cooling tower control affects the unit cycle rates. Condenser water temperature swings from 10-15°F may cause excessive compressor, water valve, and unit cycling. Be sure to set the tower controls to minimize compressor/unit cycling.

## Waterside Piping Arrangements

Install a condenser water pump between the cooling tower (either open or closed) and the self-contained unit. Lay out the remainder of the system's condenser piping in reverse returns. This helps balance the system by equalizing the length of supply and return pipes. Multistory buildings may use a direct return system with balancing valves at each floor.

Install the supply riser and its return in close proximity. Furnish both with permanent thermometers to check the waterside balance during start-up and routine maintenance checks.

Also, include strainers at each pump inlet and unit. Install drain valves at the riser's base to allow drainage points for system flushing during start-up and routine maintenance. For condenser draining and header removal, include a shutoff/balancing valve on the entering and leaving waterside pipes, drain tees, and unions of each unit. Also, install a shutoff valve on the unit entering water pipe for condenser draining.

Note: Unit does not have floor drains.

## Water Temperature Requirements

Do not allow the entering water temperature to go below 54°F (12.2°C) on units with constant water flow (basic piping). This will cause the compressors to shut down and the mechanical cooling function will lockout. However, the economizer (if enabled) will continue to function. The compressors will reset when the entering water temperature reaches 58°F (15°C).

Units with variable water flow (intermediate piping) have a modulating condensing pressure control valve that allows compressor operation down to entering water temperatures of 35°F (2°C).

For more information on constant and variable water flow, see the Sequence of Operation section of this manual.

Note: Units with a waterside economizer can be set from the human interface panel for variable or constant water flow.

**Table I-MR-1. Water Connection Sizes.**

Unit Size	Direct Condenser	Factory Piped
SCWG 20-35	1-1/2 NPT	2-1/2 NPT

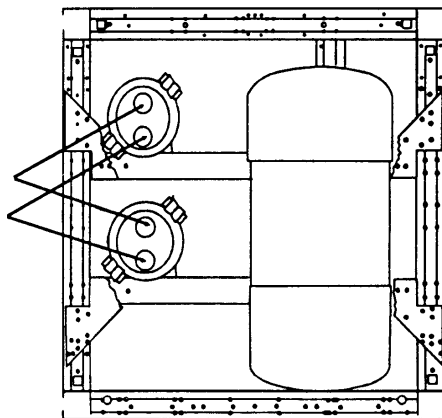

**Figure I-MR-3. Direct condenser connections.**

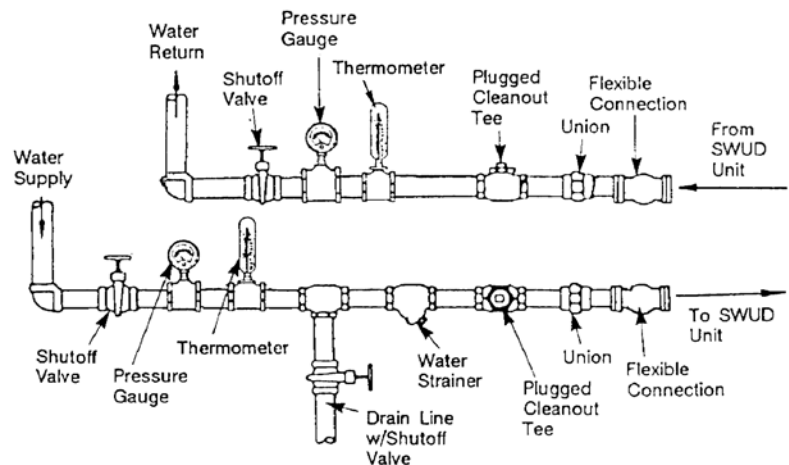

**Figure I-MR-2. Condenser water piping components for cooling tower system**

# Mechanical Specifications

## Refrigerant Piping (Air-Cooled Units Only)

See the “Startup” section of this manual for instructions on refrigerant evacuation, charging, and superheat measurement. Leak-test the entire refrigeration system after all piping is complete.

### Leak Test (Remote Air-cooled Units Only)

Units ship with a holding charge of dry nitrogen. Before installing the unit refrigerant piping, momentarily depress either the suction or discharge line access valve to verify the holding charge has not been lost. If no nitrogen escapes the access valve, leak-test the entire refrigerant system to determine the leak source. Use a halogen leak detector, a halide torch, or soap bubbles to leak test. After finding a leak, remove the test pressure and repair the leak. Retest the unit to ensure all leaks are repaired.

### Brazing Procedures

Proper brazing techniques are essential when installing refrigerant piping. The following factors should be kept in mind when forming sweat connections:

## WARNING

### Hazard of Explosion and Deadly Gases

**Never solder, braze or weld on refrigerant lines or any unit components that are above atmospheric pressure or where refrigerant may be present. Always remove refrigerant by following the guidelines established by the EPA Federal Clean Air Act or other state or local codes as appropriate. After refrigerant removal, use dry nitrogen to bring system back to atmospheric pressure before opening system for repairs. Mixtures of refrigerants and air under pressure may become combustible in the presence of an ignition source leading to an explosion. Excessive heat from soldering, brazing or welding with refrigerant vapors present can form highly toxic gases and extremely corrosive acids. Failure to follow all proper safe refrigerant handling practices could result in death or serious injury.**

1. When heating copper in the presence of air, copper oxide forms. To prevent copper oxide from forming inside the tubing during brazing, sweep an inert gas, such as dry nitrogen, through the tubing. A nitrogen flow of 6 to 10 cubic feet per hour is sufficient to displace the air in the tubing and prevent oxidation of the interior surfaces. Use a pressure regulating valve or flow meter to control the flow.
2. Ensure that the tubing surfaces requiring brazing are clean, and that the tube ends are carefully reamed to remove any burrs.
3. Make sure the inner and outer tubes of the joint are symmetrical and have a close clearance, providing an easy ‘slip’ fit. If the joint is too loose, the connection’s tensile strength is significantly reduced. Ensure the overlap distance is equal to the inner tube diameter.
4. Wrap each refrigerant line component with a wet cloth to keep it cool during brazing. Excessive heat can damage the internal components.
5. If using flux, apply it sparingly to the joint. Excess flux will contaminate the refrigerant system.
6. Apply heat evenly over the length and circumference of the joint.
7. Begin brazing when the joint is hot enough to melt the brazing rod. The hot copper tubing, not the flame, should melt the rod.
8. Continue to apply heat evenly around the joint circumference until the brazing material is drawn into the joint by capillary action, making a mechanically sound and gas-tight connection.
9. Visually inspect the connection after brazing to locate any pinholes or crevices in the joint. Use a mirror if joint locations are difficult to see.
10. Reference Tables M-MP-6 and M-MP-7 for the correct amount of refrigerant required for charging the unit.



# Electrical Requirements

## Unit Wiring Diagrams

### **⚠️ WARNING**

#### **Live Electrical Components!**

During installation, testing, servicing and troubleshooting of this product, it may be necessary to work with live electrical components. Have a qualified licensed electrician or other individual who has been properly trained in handling live electrical components perform these tasks. Failure to follow all electrical safety precautions when exposed to live electrical components could result in death or serious injury.

Specific unit wiring diagrams are provided on the inside of the control panel door. Use these diagrams for connections or trouble analysis.

## Supply Power Wiring

### **⚠️ WARNING**

#### **Hazardous Voltage w/Capacitors!**

Disconnect all electric power, including remote disconnects before servicing. Follow proper lockout/tagout procedures to ensure the power cannot be inadvertently energized. For variable frequency drives or other energy storing components provided by Trane or others, refer to the appropriate manufacturer's literature for allowable waiting periods for discharge of capacitors. Verify with an appropriate voltmeter that all capacitors have discharged. Failure to disconnect power and discharge capacitors before servicing could result in death or serious injury.

**Note:** For additional information regarding the safe discharge of capacitors, see PROD-SVB06A-EN or PROD-SVB06A-FR.

It is the installer's responsibility to provide power supply wiring to the unit terminal block or the non-fused disconnect switch option. Wiring should conform to NEC and all applicable code

requirements.

Bring supply wiring through the knockout in the lower left side of the unit control panel. Connect the three phase wires to the power terminal block or the non-fused disconnect switch in the control box terminals. Refer to specific wiring diagrams and fuse information in the unit's control panel.

### **NOTICE**

#### **Use Copper Conductors Only!**

Unit terminals are not designed to accept other type conductors. Failure to use copper conductors may result in equipment damage.

### **NOTICE**

#### **Equipment Damage!**

Correct phase sequence is critical. If phase sequence of the incoming line voltage is not correct, it may result in motor damage.

### **Voltage Range**

Voltages must be within +/- 10% the nameplate voltage. Ensure the unit voltage is balanced by measuring at the compressor terminals. Voltage imbalance on three phase systems can cause motor overheating and premature failure. Maximum allowable imbalance is 2.0%.

### **Voltage Imbalance**

Read the voltage at the compressor terminals to determine if it is balanced. Voltage imbalance on three phase systems can cause motor overheating and premature failure. The maximum allowable imbalance is 2.0%. Voltage imbalance is defined as 100 times the sum of the deviation of the three voltages from the average (without regard to sign) divided by the average voltage. For example, if the three measured voltages are 221, 230, and 227, the average voltage would be:

$$\frac{(221 + 230 + 227)}{3} = 226 \text{ volts}$$

The percentage of voltage imbalance is then:

$$100 * \frac{(226-221)}{226} = 2.2\%$$

## Control Power

### **NOTICE**

#### **Component Failures!**

Unit transformers IT1, IT3, 1T4, and IT5 are sized to provide power to the unit only. Do not use these transformers to supply power to field equipment. Field connections to these transformers may create immediate or premature component failures.

In this example, 2.2% imbalance is not acceptable. Whenever a voltage imbalance of more than 2.0% exists, check the voltage at the unit disconnect switch. If the imbalance at the unit disconnect switch does **not** exceed 2.0%, faulty unit wiring is causing the imbalance. Conduct a thorough inspection of the unit electrical wiring connections to locate the fault, and make any repairs necessary.

Access the connection terminal block through the control panel on the unit's upper left side. All wiring should conform to NEC and applicable local code requirements.

Be sure all wiring connections are secure. Reference the unit specific diagrams inside the control panel.



# Electrical Requirements

## Selection Procedures

RLA = rated load amps

Compressor LRA = locked rotor amps

Fan motor LRA = locked rotor amps, N.E.C. table 430 - 150

FLA = full load amps, N.E.C.

Table 430 - 150

Voltage utilization range is  $\pm 10\%$

Determination of minimum circuit ampacity (MCA).

MCA = 1.25 x largest motor amps/VFD amps (FLA or RLA) + the sum of the remaining motor amps.

Determination of maximum fuse size (MFS) and maximum circuit breaker size (MCB).

MFS and MCB = 2.25 x largest motor amps (FLA or RLA) + the sum of the remaining motor amps.

For units with the dual power option, there are two electrical circuits that need calculations using the formulas above:  
 circuit #1 - fans  
 circuit #2 - compressors

If the rating value determined does not equal a standard current rating of over current protective device, use the next lower standard rating for the marked maximum rating.

**Table ED-1. Number of Compressors per Unit**

SCWG/SIWG	20	25	30	35
SCRG/SIRG	20		25	32
10 HP	2	2	1	-
15 HP	-	-	1	2

**Table ED-2. SCWG/SIWG Compressor Motor Data**

HP	200V		460V		575V	
	RLA	LRA	RLA	LRA	RLA	LRA
10	33.1	269	14.4	117	11.5	94
15	46.9	409	20.4	178	16.4	143

**Table ED-3. SCRG/SIRG Compressor Motor Data**

HP	200V		460V		575V	
	RLA	LRA	RLA	LRA	RLA	LRA
10	38.4	269	16.7	117	13.4	94
15	55.0	409	24.1	178	19.1	143

**Table ED-4. Fan without VFD**

HP	200V		460V		575V	
	FLA	LRA	FLA	LRA	FLA	LRA
5	16.1	105	6.7	46	5.4	37
7.5	25.0	152	10.8	66	8.2	54
10	32.9	193	14.2	84	11.4	66
15	44.8	290	20.3	126	16.2	102
20	61.0	373	25.0	162	20.0	132
25	74.0	469	31.0	204	24.2	162

**Table ED-5. Fan with VFD**

HP	200V		460V	
	FLA	LRA	FLA	LRA
7.5	13.8	152	10.6	66
10	32.2	193	14.2	84
15	48.3	290	21.0	126
20	61.9	373	27.6	162
25	78.2	469	34.0	204

Note: Values are at the maximum VFD input rating and not the reduced motor values.

**Table ED-6. Electric Heat - Single Stage**

SCWG/SIWG Size	SCRG/SIRG Size	Heat Kw	200V Amps	460V Amps
20	20	16	44.8	19.6
25	25	20	55.6	24.2
30	-	24	66.8	29.0
-	32	26	72.4	31.6
35	-	28	78	34.0

Note: Electric heat amperage should not be considered when determining minimum circuit ampacity. The current of the unit in the heating mode will not exceed the current of the unit in the cooling mode.

**Table ED-7. CCRC/CIRC Condenser Electrical Data**

Unit Size Tons	Rated Voltage	# Fans	FLA (ea.)	LRA (ea.)	MCA	MFS/MCB
20, 29, 32	200	4	4.1	20.7	17.4	20
	230	4	4.1	20.7	17.4	20
	460	4	1.8	9.0	7.7	15
	575	4	1.4	7.2	6.0	15

Note: All motors for CCRC/CIRC units are rated at 1 hp (.7457 kW).

# pre-startup requirements

## Installation

### Pre-Startup Procedures

#### **⚠️ WARNING** Hazardous Voltage w/Capacitors!

Disconnect all electric power, including remote disconnects before servicing. Follow proper lockout/tagout procedures to ensure the power cannot be inadvertently energized. For variable frequency drives or other energy storing components provided by Trane or others, refer to the appropriate manufacturer's literature for allowable waiting periods for discharge of capacitors. Verify with an appropriate voltmeter that all capacitors have discharged. Failure to disconnect power and discharge capacitors before servicing could result in death or serious injury.

**Note:** For additional information regarding the safe discharge of capacitors, see PROD-SVB06A-EN or PROD-SVB06A-FR.

Before starting up units perform the following procedures to ensure proper unit operation.

#### Unit Protective Covers

Remove the shipping protection coverings from the human interface panel (HI) at the control panel, the filter box (or air inlet opening), the discharge air opening, and optional variable frequency drive (VFD).

#### Compressor Isolators

Loosen compressor isolator mounting bolts and remove shipping bracket from beneath the compressor feet. Retighten isolator mounting bolts. Torque to 18 ft. lbs. (+ 2 ft. Lbs.)

#### Supply Fan Isolators

Remove the shipping channels and mounting bolts from beneath the fan. See Figure I-PR-1. Open both fan compartment access doors to access the channels. There are four mounting points for 20-38 ton units and six mounting points for 40-80 ton units. See Fig I-PR-2.

**Note:** For 20-38 ton units, do not remove the fan assembly shipping blocks and tie down bolts if the fan speed is 750 rpm or less.

While keeping the fan mounting frame level, turn the fan isolator height adjusting bolts until the fan housing P-gasket compresses  $\frac{1}{4}$ " against the roof transition piece. See Figure I-PR-1.

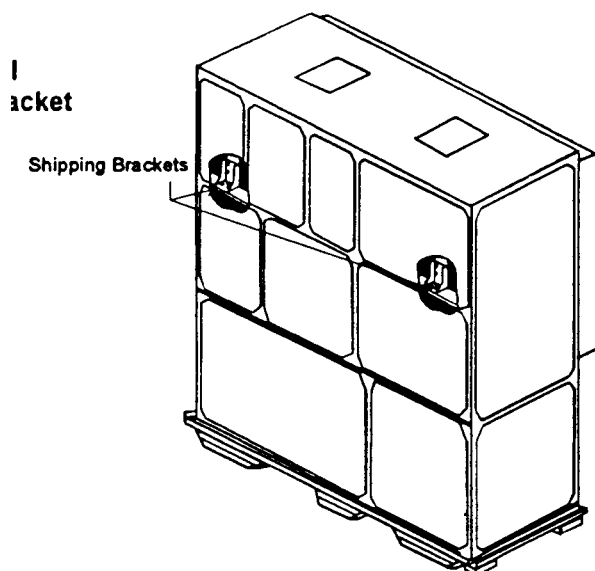

Figure I-PR-1. Supply fan horizontal isolation shipping bracket.

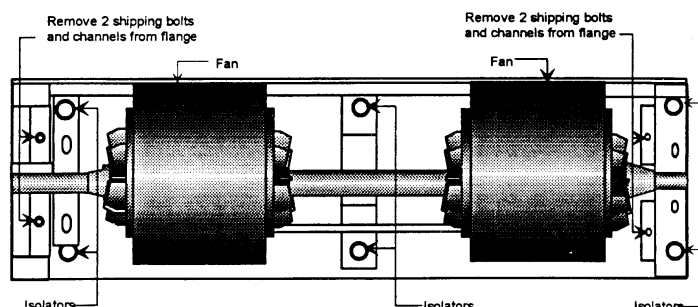
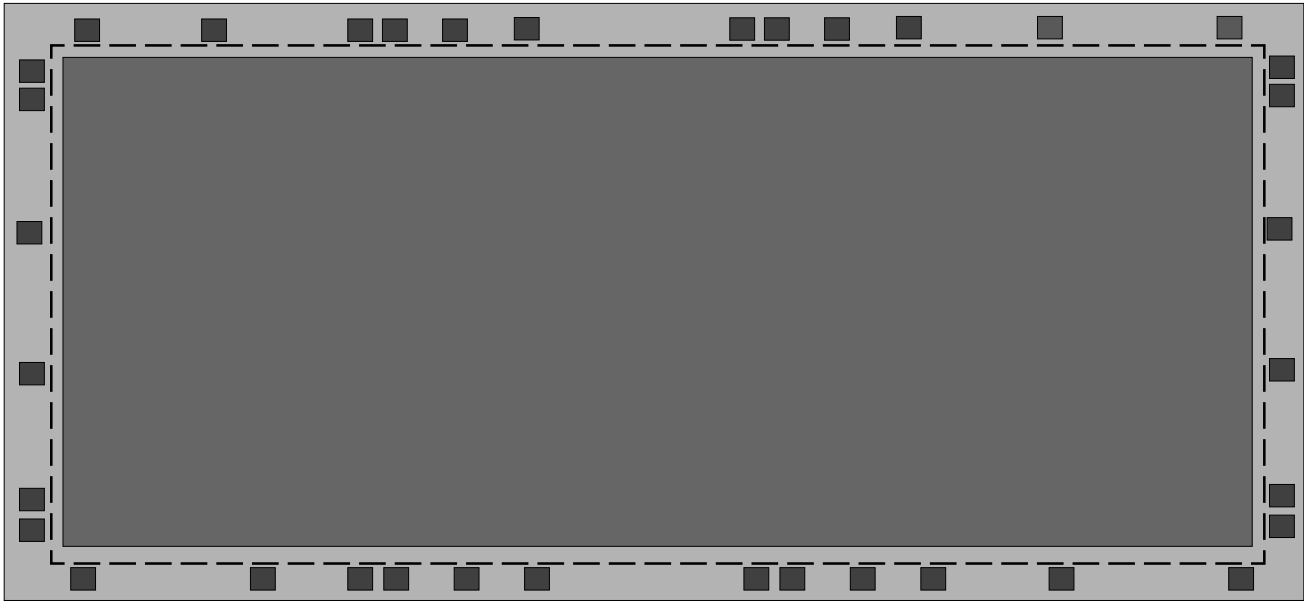

Figure I-PR-2. Fan isolator locations.

Plenum Bottom View



Dashed line indicates correct insulation placement.

**Figure I-PR-3. Correct plenum insulation placement**

## Plenum

Before installing the plenum attach the insulation strip that ships with the plenum. See Figure I-PR-3 for proper insulation location. Align the plenum front with the control panel side of the unit. Using the strips and screws provided, secure the plenum to the unit.

Treat field-cut holes to prevent fiberglass from entering the airstream.

---

Note: Plenum insulation must be applied properly to prevent air bypass around the plenum. See Figure I-PR-3.

---

# Installation

## pre-startup requirements

### Airside Economizer Installation

Note: Airside economizer option available on 20-80 tons only.

#### Unit Handling

1. Hoist the damper cabinet to the installation location with straps positioned under the skid as shown in Figure I-PR-4. Use spreader bars to prevent unit damage during lifting.
2. With the damper cabinet at its final location (near the unit), remove the screws securing it to the skid from the side flanges. Retain these screws for later use.

#### Unit Preparation

3. The support legs are secured to the skid, and the hanging bracket is secured with wire ties to an inside flange near the cabinet's base. Remove the C-channel collar and install it on the unit, if not already installed.
4. Remove the roll of  $\frac{1}{8}$ " thick gasket from the damper cabinet's W-supports, and apply it to the C-channel collar mounted on the rear of the unit. This gasket will provide a seal between the damper cabinet and the unit.
5. Attach the legs (with screws provided) to the leg brackets located on the damper's base.
6. Attach a field-provided clevis of suitable strength ( $\geq \frac{1}{2}$ " ), to each of the corner lifting brackets through the  $\frac{7}{8}$ " diameter holes.
7. Attach to the clevises a means of lifting the damper cabinet from its skid.

#### Unit Installation

8. Slowly raise the damper cabinet from its skid.
9. Attach the hanging bracket across the front of the damper cabinet. Position it with its short flange pointing to four

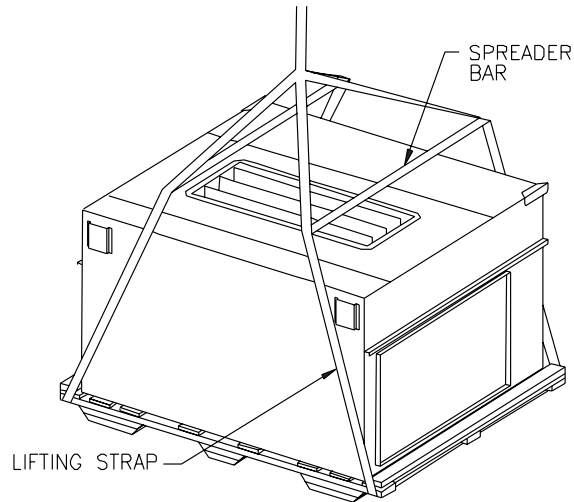

Figure I-PR-4. Proper lifting of the airside economizer

- o'clock, and secure it with screws provided. See Figure I-PR-5.
10. Lift the damper cabinet and position it such that the hanging bracket is positioned over the unit's C-channel collar.
11. Lower the damper cabinet until the holes in its side flanges are aligned with the holes in the C-channel collar. Install screws removed in step 3 through the damper cabinet's side flanges and into the C-channel's corresponding holes.
12. Attach ductwork to the top and back dampers according to local codes.

#### Field Wiring Connections

13. Open the damper cabinet's door and connect the **factory-provided plug** from the actuator to the **factory-provided plug** in the unit's filter section.

#### 14. Cabinets with TRAQ dampers only:

Unroll the two rolls of pneumatic tubing located inside the damper cabinet. Route these tubes through the cabinet's front upper panel (0.25 dia. holes provided). Connect them to the two pneumatic tubes protruding from the customer electrical connection panel on the unit. Be sure to connect like tubes to each other (black to black, white stripe to white stripe).

#### 15. Cabinets with TRAQ dampers only:

Locate the "bullet" sensor and rolled up wiring in the unit's filter section. Route it into the damper cabinet and insert the sensor into the sensor mounting clip attached to underside of one of the Traq dampers.

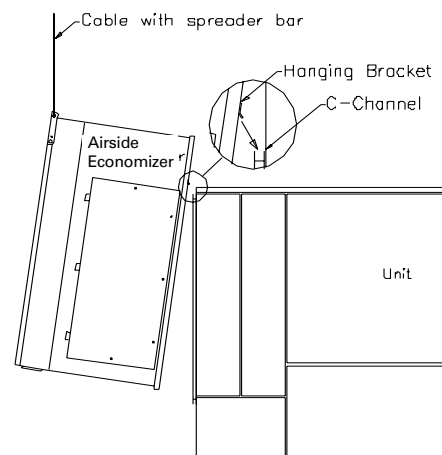

Figure I-PR-5. Proper installation of the airside economizer option

# Installation

## pre-startup requirements

### Static Pressure Transducer Installation (VAV units only)

Supply air static pressure controls the inlet guide vane and inverter options. A static pressure head assembly ships separate in the control panel for field installation in the supply air duct work. The installer is responsible for providing pneumatic tubing.

#### Transducer Location

Place the head assembly in an area of the ductwork that will provide an average and evenly distributed airflow pattern. Use the following guidelines to determine an appropriate installation location.

1. Locate the static head assembly about  $\frac{2}{3}$  to  $\frac{3}{4}$  of the way down the longest duct run, in an area approximately 10 duct diameters downstream and 2 duct diameters upstream of any major interferences, turns, or changes in duct diameter.
2. When installing pneumatic tubing between the head assembly and transducer in the control panel, do not exceed 250 feet for  $\frac{1}{4}$ " OD tubing or 500 feet for  $\frac{3}{8}$ " OD tubing.

#### Installing the Transducer

Complete the following procedure to properly install the inlet guide vane static pressure transducer.

1. Mount the pressure sensing head assembly in the duct so that the sensing tip is in the middle of the duct so that it will provide a proper pressure measurement. See Figure I-PR-6.
2. Connect the pneumatic tubing from the sensing head to the push-on tubing connection in the control panel. Use a plastic static pickup tubing. Do not exceed 250 feet for  $\frac{1}{4}$ " OD tubing or 500 feet for  $\frac{3}{8}$ " OD tubing.

The transducer inside the control panel picks up low side or reference pressure.

Note: If plastic tubing pulls away from a connection, trim it back before replacing it on the fitting. Stretched tubing may leak and cause faulty control.

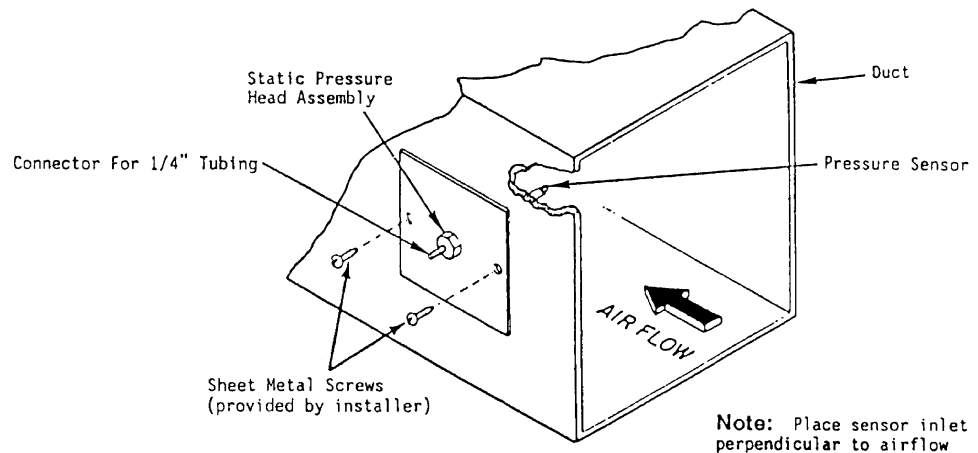

Figure I-PR-6. Static pressure sensor installation

# Installation

## pre-startup requirements

### Waterside Economizer Installation Procedure

1. Loosen and pull all end devices that go through the bushing on the filter rack (upper right corner of rack).
2. Remove the filter rack from the back of the unit by removing the  $\frac{1}{4}$ " hex head screws from the top and bottom of the filter rack assembly. The filter rack assembly will hang on the unit when the screws are removed. Remove the filter rack by lifting it up off the unit.
3. Remove the economizer from the crate and position it behind the unit with the headers on the left side, when facing the back of the unit. Remove the plastic envelope that is taped to the economizer box assembly. This envelope contains the gasket that must be installed onto the vertical side flanges of the box.
4. Install the pressure sensitive gasket to the unit side of the vertical flange on the economizer box.
5. Hang the economizer on the unit as shown in Figure I-PR-7. Lift the economizer by using the holes provided in the top panel of the economizer.
6. Align economizer holes with the holes in the unit channel. Install screws in the top (6x) and bottom (6x) of the economizer.
7. Remove the unit's rear middle panel and unbrazed the two copper pipes in the  $2\frac{5}{8}$ " water pipe. Do not remove the pipe outlet blockoff panel.
8. Remove the economizer tubing assemblies from the shipping box. Check ship-separate parts against those shown in Figures I-PR-8, I-PR-9, I-PR-10, and I-PR-11. Face the front of the unit to see which side the water pipe exits to determine if the unit has either right or left-hand piping.
9. Assemble tubing as shown in Figure I-PR-8 or I-PR-11. Tack all tubes in place before brazing to ensure proper fit-up. For right-hand piped units, install the ball valve actuator assembly and actuator as shown in Figure I-PR-10. Refer to the unit wiring diagram for wiring connection points.
10. Install the pipe insulation on all pipe line to prevent sweating
11. Install the rear panels.
12. Re-install the filter rack on the back of the economizer coil box and affix with screws provided.

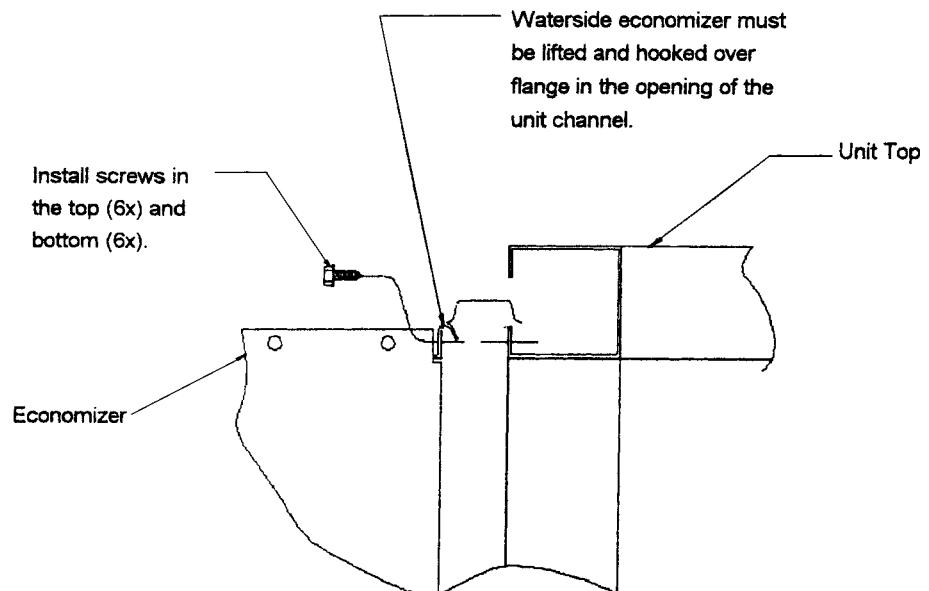
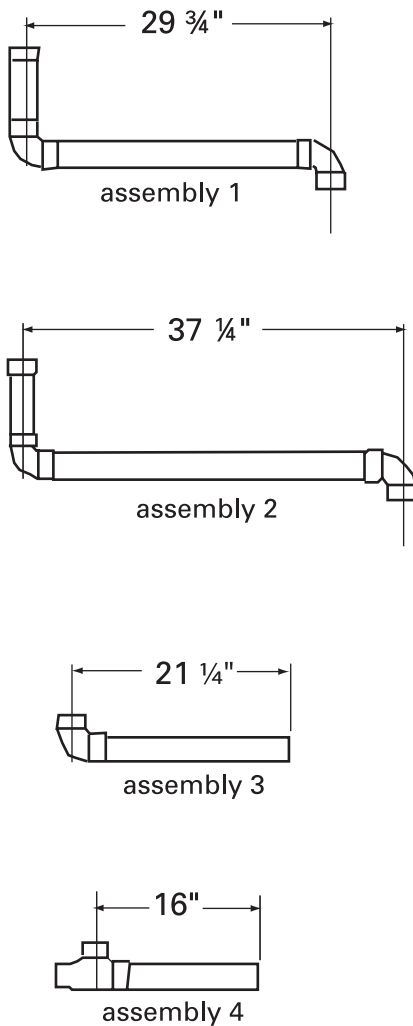

Figure I-PR-7. Installing the waterside economizer.

# Installation

## pre-startup requirements

### Waterside Economizer with left-hand factory piping components



**Figure I-PR-8. Detail view of ship-separate tubing assemblies for waterside economizer left-hand piping**

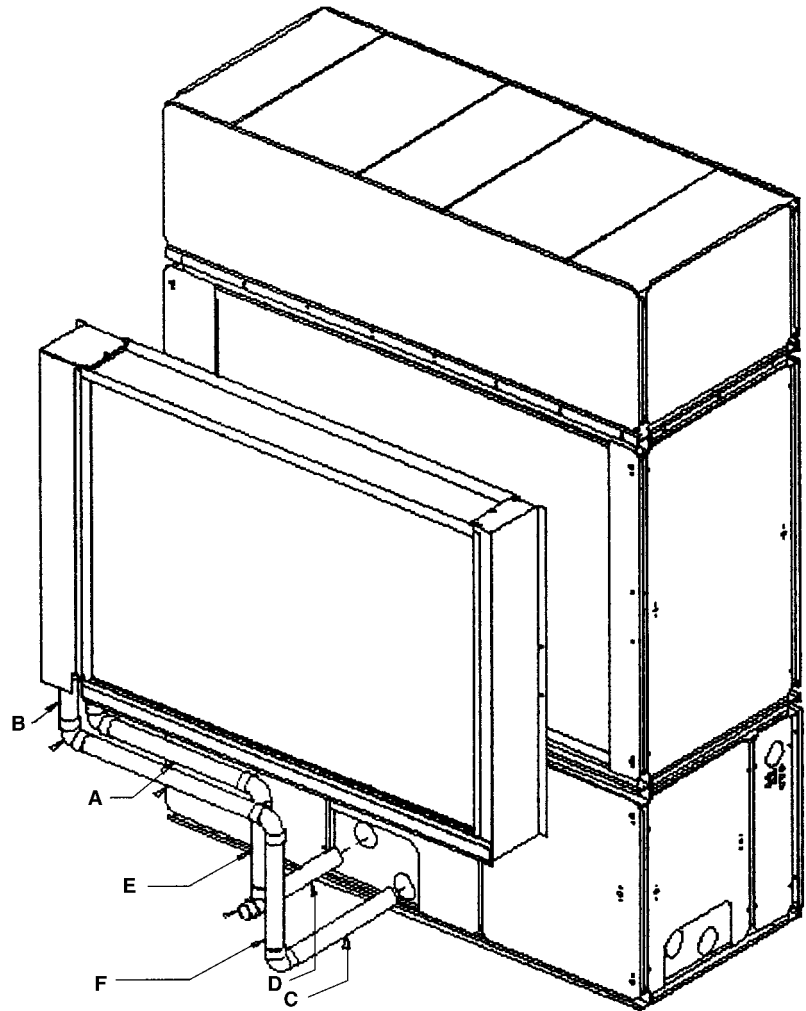

**Figure I-PR-9. Waterside economizer with left-hand factory piping tubing assembly**

Item	Part Description
A	Assembly #1
B	Assembly #2
C	Assembly #3
D	Assembly #4
E	Tube; 2 5/8" x 16 7/8"
F	Tube; 2 5/8" x 22 5/8"

#### Waterside Economizer Ship-Separate Parts List

Factory Piping	Item Part #	Qty.	Description
Left-Hand	4001	2	Tube; 2 5/8" x 9"
	X17110026250	5	Elbow; 2 5/8" x 2 5/8"
	4003	1	Tube; 2 5/8" x 26 1/8"
	4740	1	Tube; 2 5/8" x 33 1/2"
	4009	1	Tube; 2 5/8" x 14 7/8"
	X21040098390	10 ft.	Gasket
	X21080406110	1	Insulation; 2 5/8" Rubatex
	X16120203570	1	Plug; 1 1/2" Brass
	X17150027060	1	Bushing; 2 1/2" ftg. x 1 1/2"
	X17170031210	1	Tee; 2 5/8" x 2 1/8" x 2 5/8"
	4738	1	Tube; 2 5/8" x 19 3/4"
	4007	1	Tube; 2 5/8" x 14 1/2"
	X45000032020	1 roll	Tape, 1.5' wide
	4006	1	Tube; 2 5/8" x 19 15/16"



# Installation

## pre-startup requirements

### Waterside Economizer with right-hand factory piping components

#### Waterside Economizer Ship-Separate Parts List

Factory Piping	Item Part #	Qty.	Description
Right-Hand	4001	1	Tube; 2 5/8" x 9"
	4607	1	Tube; 2 5/8" x 17"
	X17110026250	5	Elbow; 2 5/8" x 2 5/8"
	4605	2	Tube; 2 5/8" x 9 1/2"
	X15330177010	1	Water Valve
	4008	1	*Tube; 2 5/8" x 20 1/4"
	X17170031210	1	Tee; 2 5/8" x 2 1/8" x 2 5/8"
	X16120203570	1	Brass Plug, 1 1/2"
	X17150027060	1	Bushing; 2 1/8" ftg. x 1 1/2"
	4007	1	Tube; 2 5/8" x 14 1/2"
	4031	1	Tube; 2 5/8" x 62"
	4603	1	*Tube; 2 5/8" x 11 3/4"
	4006	1	Tube; 2 5/8" x 19 1/4"
	X13610256010	1	*Actuator with wires
	X19110028040	2	*90 Degree Conduit Fitting
	X19110028040	3 ft.	*1/2" Conduit
	X210804060110	14 ft.	*Rubatex Insulation, 2 5/8"
	X45000032020	1 roll	Tape, 1.5' wide
	X21040098390	10 ft.	*Gasket

Item	Part Description
A	Assembly #1
B	Assembly #2
C	Assembly #3
D	Assembly #4
E	Tube; 2 5/8" x 11 3/4"
F	Tube; 2 5/8" x 20 1/4"
G	Actuator Assembly

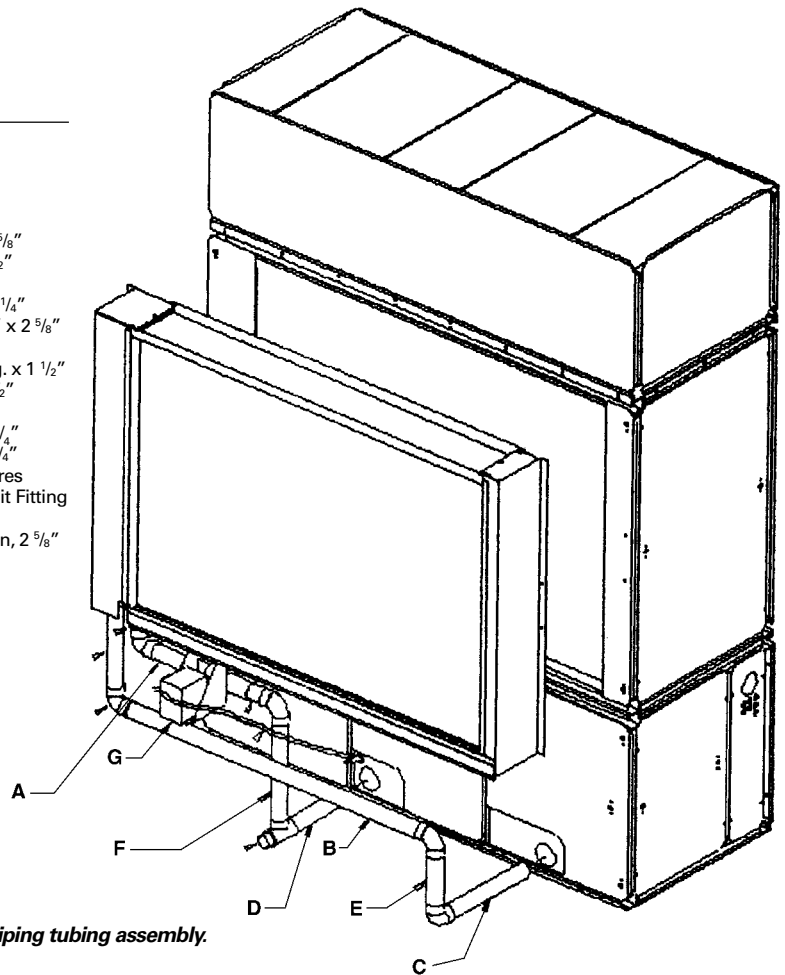

Figure I-PR-10. Waterside economizer with right-hand factory piping tubing assembly.

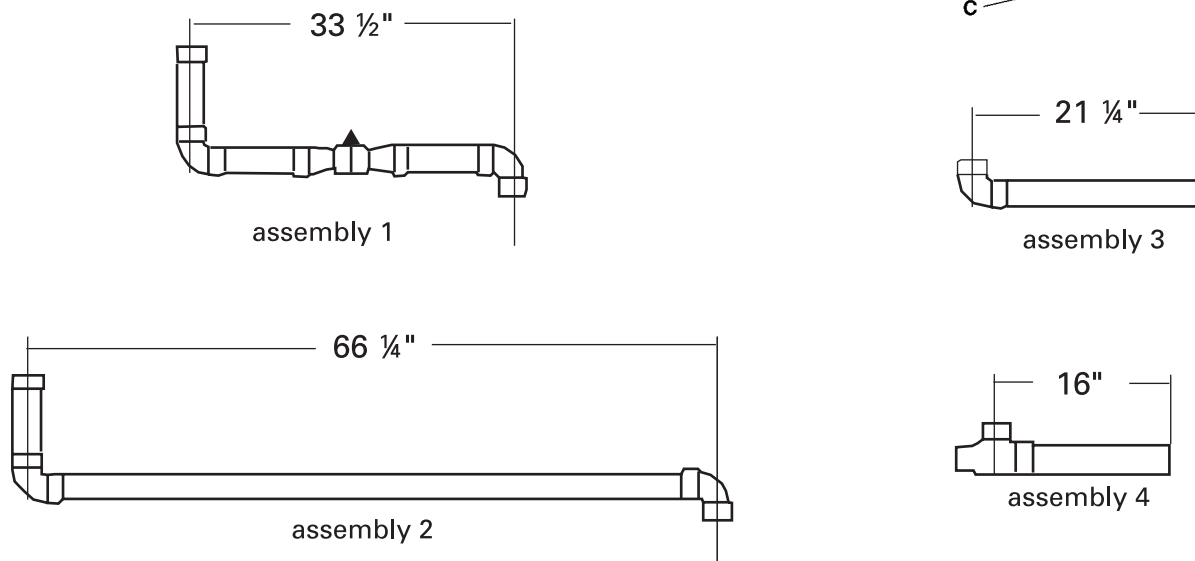

Figure I-PR-11. Detail view of ship-separate tubing assemblies for waterside economizer right-hand factory piping.

# Installation

## pre-startup requirements

### Hydronic Coil Installation

These instructions are for steam and hot water coil installation. The hydronic coil assembly has a full coil, piping, a modulating temperature control valve, and a disc temperature limit device located in the unit near the fan on the motor frame. Hydronic coils are available with either right or left-hand pipe connections. Piping connections are identical to the unit piping. For example, if you have right-hand unit piping, the hydronic coil will have right-hand connections. The hydronic coil assembly has temperature controls to keep the unit's internal cabinet temperature below 105 F to prevent motor and bearing damage.

#### Installation Procedure

#### **WARNING**

#### **Unit Structural Integrity!**

**Unit panels provide structural integrity. Do not remove more than two non-adjacent panels at one time as this could cause the plenum frame to collapse. Failure to follow these recommendations could result in death, serious injury or equipment damage.**

1. Remove filter rack from the back of the unit. Remove the  $\frac{1}{4}$ -inch hex head screws from the top and bottom of the filter rack assembly. The filter rack assembly will hang on the unit when the screws are removed. The filter rack can now be removed by lifting up on the filter rack.
2. Remove the hydronic coil from the crate and position it behind the unit with the open side facing the unit evaporator coil inlet. Also, remove the plastic envelope that is taped to the coil box assembly. This envelope contains the

mounting screws needed to attach the coil box to the unit and the gasket required on the vertical side flanges of the box.

3. Install the pressure sensitive gasket to the unit side of the vertical flange on the coil box in two places.
4. Using 2" x  $\frac{1}{2}$ " standard thread eyebolts, thread into the coil lift plates to raise the coil up to the height necessary to attach it to the unit. The top panel has a "J" hook on it to allow hanging, similar to the filter rack. Align the holes so that the coil hangs on the unit. If the unit has the dirty filter option, connect the static pressure tube to the unit before bolting the coil in place. Locate the static pressure tubing on the unit evaporator coil and route through the knockout in the top corner of the coil box.
5. Align the hydronic coil with the holes in the unit channel or waterside economizer option. Move the coil box up against the unit and install using six mounting screws in the top and six in the bottom of the coil box.
6. Remove the valve and pipe cover on the coil box. Connect the wires that are coiled in the coil box, referring to the wiring diagram installed on the unit control panel door. Route wires into the unit through knockouts in the top of the box.
7. Reinstall the filter rack on the back of the heating coil rack. If the unit has the waterside economizer option, the filter rack will require additional support legs.

# pre-startup requirements

## Installation

### Electric Heat Installation

The electric heat option consists of a single stage heater and is used in IntelliPak units or units with a field-installed thermostat. The electric heater ships separate for field installation and wiring. Available heater kW per unit size is listed in Table I-PR-2. Electric heat can be installed on units with a vertical discharge. However, it cannot be installed on units with plenums. See Figure I-PR-12 and Table I-PR-3 for electric heat dimensional data.

Table I-PR-2. Available Electric Heat kW

Unit Size	Heater kW
20 Tons	16
25 Tons	20
30 Tons	24
32 Tons	26
35 Tons	28

### Installation Procedure

1. Remove the fan discharge shipping covers, if they have not already been removed.
2. Install the open-cell gasket around the discharge opening on the heater.
3. Position the electric heater so that the unit fan discharge openings line up with the electric heater openings. For a

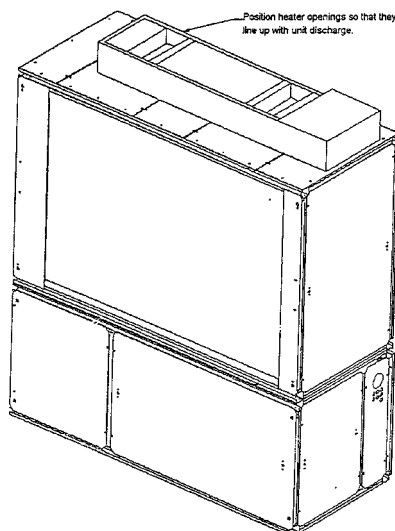

Figure I-PR-12. Vertical discharge electric heat installation.

- vertical discharge unit, position the electric heater as shown in Figure I-PR-12.
4. Use the hole pattern in the electric heat as a template for marking and drilling  $\frac{3}{16}$ " diameter holes in the unit.
  5. Bolt the electric heaters to the unit using  $\frac{1}{4}$ " sheetmetal screws.

Note: It is very important that electric heaters are selected based on unit voltage and tonnage because discharge opening sizes vary by unit tonnage.

### Electric Heat Coil Wiring Procedure

#### NOTICE

#### Use Copper Conductors Only!

Unit terminals are not designed to accept other type conductors. Failure to use copper conductors may result in equipment damage.

#### WARNING

#### Hazardous Voltage w/Capacitors!

Disconnect all electric power, including remote disconnects before servicing.

Follow proper lockout/tagout procedures to ensure the power cannot be inadvertently energized. For variable frequency drives or other energy storing components provided by Trane or others, refer to the appropriate manufacturer's literature for allowable waiting periods for discharge of capacitors. Verify with an appropriate voltmeter that all capacitors have discharged. Failure to disconnect power and discharge capacitors before servicing could result in death or serious injury.

Note: For additional information regarding the safe discharge of capacitors, see PROD-SVB06A-EN or PROD-SVB06A-FR.

1. Before wiring the electric heater, remove the unit wiring diagram from the unit control panel and refer to the connection points.

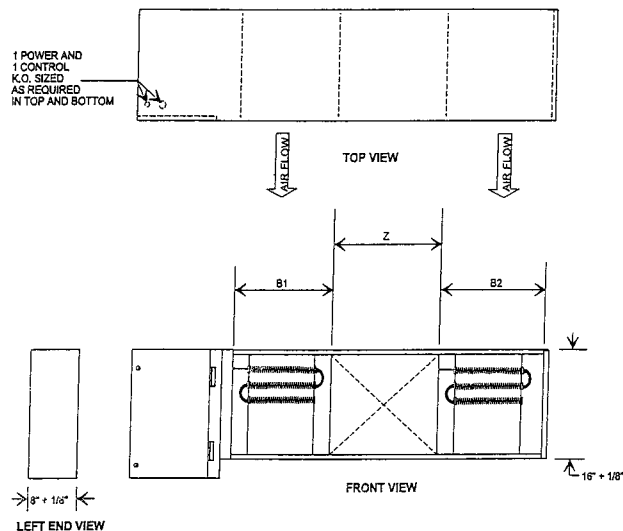

Figure I-PR-12. Electric heater dimensions.

Table I-PR-3. Electric Heat Dimensions - English - (inches)

Unit Size	B1	B2	Z
20 Tons	10 $\frac{3}{4}$	15 $\frac{5}{8}$	27 $\frac{3}{4}$
25 Tons	12 $\frac{1}{4}$	15 $\frac{5}{8}$	26 $\frac{3}{4}$
30, 32, 35 Tons	14 $\frac{3}{4}$	15 $\frac{5}{8}$	23 $\frac{3}{4}$

## Installation

### Standard with All IntelliPak Units



Figure I-PR-7. BAYSENS077 zone temperature sensor only

### Zone Sensor Options for IntelliPak Control Units

Zone sensor options are available and be ordered with the unit or after the unit ships. Following is a full description of zone sensors and their functions. Installation instructions are on page 34. Programming instructions for the programmable zone sensor are on page 36. Refer to Table O-GI-2 on page 61 for the zone sensor temperature vs. resistance coefficient curve.

#### BAYSENS077\* Description

This zone sensor module ships with all units, and can be used with BAYSENS019, BAYSENS020, or BAYSENS021 remote sensors. When this sensor is wired to one of these remote zone sensors, wiring must be 18 AWG shielded twisted pair (Belden 8760 or equivalent). Refer to the specific zone sensor for wiring details. It provides the following features and system control functions:

- Remote temperature sensing in the zone
- Morning warmup sensor
- Zone sensor for ICS™ systems
- Zone temperature averaging

When used as a remote sensor for standard zone sensor, the thermistor sensor must be disabled.

(Possible Schematic Designation(s): 5U23, 5U26, 5U30, and 5RT5.)

### CV Unit Zone Sensor Options



Figure I-PR-8. BAYSENS108 Dual setpoint, manual/automatic changeover sensor, accessory model number digit 6 = E

#### BAYSENS108 & BAYSENS110 Description

These zone sensor modules are for use with cooling/heating constant volume units. They have four system switch settings (heat, cool, auto, and off) and two fan settings (on and auto). The zone sensor provides either manual or automatic chaneover control with dual setpoint capability.

BAYSENS108 and BAYSENS110 features and system control functions include:

- System control switch to select heating mode (HEAT), cooling mode (COOL), automatic selection of heating or cooling as required (AUTO), or to turn the system off (OFF).
- Fan control switch to select automatic fan operation while actively heating or cooling (AUTO), or continuous fan operation (ON).
- Dual temperature setpoint levers for setting desired temperature. The blue lever controls cooling, and the red lever controls heating.
- Thermometer to indicate temperature in the zone. This indicator is factory calibrated.

(Possible Schematic Designation: 5U29)



Figure I-PR-10. BAYSENS110 Dual setpoint, manual/automatic changeover sensor with system function lights, accessory model number digit 6 = F

BAYSENS110-Specific Feature: Function status indicator lights:

- SYSTEM ON glows continuously during normal operation, or blinks if system is in test mode.
- COOL glows continuously during cooling cycles, or blinks to indicate a cooling system failure.
- HEAT glows continuously during heating cycles, or blinks to indicate a heating system failure.
- SERVICE blinks or glows to indicate a problem. These signals vary depending on the particular equipment being used.

(Possible Schematic Designation: 5U29)

## Installation

### CV and VAV Unit Zone Sensor Options



**Figure I-PR-11. BAYSENS074**  
Zone temperature sensor w/timed override and local setpoint adjustment, accessory model number digit 6 = C



**Figure I-PR-12. BAYSENS073**  
Zone temperature sensor w/timed override, accessory model number digit 6 = B

### VAV Unit Zone Sensor Option



**Figure I-PR-9. BAYSENS021**  
Single setpoint sensor with system function lights, accessory model number digit 6 = H

### Integrated Comfort™ Systems Sensors for CV and VAV Applications

These zone sensor options are for use with cooling/heating Integrated Comfort System (ICS) systems.

#### BAYSENS074 Description

This electronic analog sensor features single setpoint capability and timed override with override cancellation.

BAYSENS074 features and system control functions include:

- Remote temperature sensing in the zone
- A timed override button to move an ICS or a building management system from its "unoccupied" to "occupied" mode.
- Thumbwheel for local setpoint adjustment
- A cancel button to cancel the "unoccupied override" command.

(Possible Schematic Designation: 5U23)

#### BAYSENS073 Description

This electronic analog sensor features single setpoint capability and timed override with override cancellation. It is used with a Trane Integrated Comfort system.

BAYSENS073 features and system control functions include:

- Remote temperature sensing in the zone
- A timed override button to move an ICS or a building management system from its "unoccupied" to "occupied" mode.
- Cancel button to cancel the "unoccupied override" mode.

(Possible Schematic Designation: 5U23)

#### BAYSENS021 Description

This zone sensor module is for use with VAV units without night setback. It allows the user to control system operation and monitor unit operating status from a remote location. The sensor has a system switch, a S/A temperature setpoint indicator, a local sensor, and four LED's.

BAYSENS021 features and system control functions include:

- Temperature sensing in the zone
- System control switch with mode setting for "AUTO" and "OFF"
- Supply air single temperature setpoint
- Function status indicator lights:
  - "SYS ON" glows continuously during normal operation, or blinks if system is in test mode.
  - "COOL" glows continuously during cooling cycles, or blinks to indicate a cooling system failure.
  - "HEAT" glows continuously during heating cycles, or blinks to indicate a heating system failure.
  - "SERVICE" blinks or glows to indicate a problem. These signals vary depending on the particular equipment being used.

(Possible Schematic Designation: 5U25)



# Installation

## pre-startup requirements



Standard zone sensors, BAYSENS077, ships with all units

### Zone Sensor Installation

All sensor options ship in the main control panel and are field-installed. Programmable option installation procedures.

#### Mounting Location

Mount the sensor on the wall in an area with good air circulation at an average temperature. Avoid mounting space temperature sensor in areas subject to the following conditions:

- Drafts or “dead” spots behind doors or in corners
- Hot or cold air from ducts
- Radiant heat from the sun or appliances
- Concealed pipes and chimneys
- Unheated or non-cooled surfaces behind the sensor, such as outside walls
- Airflows from adjacent zones or other units

To mount the sensors, remove the dust cover and mount the base on a flat surface or 2" x 4" junction box. Sensors ship with mounting screws.

#### Mounting the Subbase

### **⚠**WARNING

#### **Hazardous Voltage w/Capacitors!**

**Disconnect all electric power, including remote disconnects before servicing. Follow proper lockout/tagout procedures to ensure the power cannot be inadvertently energized. For variable frequency drives or other energy storing components provided by Trane or others, refer to the appropriate manufacturer’s**

**literature for allowable waiting periods for discharge of capacitors. Verify with an appropriate voltmeter that all capacitors have discharged. Failure to disconnect power and discharge capacitors before servicing could result in death or serious injury.**

**Note: For additional information regarding the safe discharge of capacitors, see PROD-SVB06A-EN or PROD-SVB06A-FR.**

### NOTICE

#### Use Copper Conductors Only!

**Unit terminals are not designed to accept other types of conductors. Failure to use copper conductors may result in equipment damage.**

Remove the zone sensor cover from subbase, and mount subbase on the wall or on a 2 x 4 junction box. Route wires through the wire access hole in the subbase. See Figure I-PR-14. Seal the hole in the wall behind the subbase.

Note: Guidelines for wire sizes and lengths are shown in Table I-PR-1. The total resistance of these low voltage wires must not exceed 2.5 ohms per conductor. Any resistance greater than 2.5 ohms may cause the control to malfunction due to excessive voltage drop.

Note: Do not run low-voltage control wiring in same conduit with high-voltage power wiring.

#### Wiring

1. Run wires between the unit control panel and the zone sensor subbase. To determine the number of wires required, refer to the unit wiring diagrams.
2. Connect the wiring to the appropriate terminals at the unit control panel and at the zone sensor subbase. In general, zone sensor connections to the unit use the convention of connecting zone sensor terminals to like numbered unit terminals (1 to 1, 2 to 2, etc.). The connection detail is shown on the unit wiring diagrams, which are located in

- the unit control panel.
3. Replace the zone sensor cover back on the subbase and snap securely into place.

#### Standard Remote Sensor (BAYSENS077)

When using the remote sensor, BAYSENS077, mount it in the space that is to be controlled. Wire according to the interconnecting wiring diagrams on the unit.

Table I-PR-1. Zone sensor maximum lengths and wire size

Distance from Unit to Controller	Recommended Wiring Size
0-150 feet	22 gauge
151-240 feet	20 gauge
241-385 feet	18 gauge
386-610 feet	16 gauge
611-970 feet	14 gauge

# Installation

## pre-startup requirements

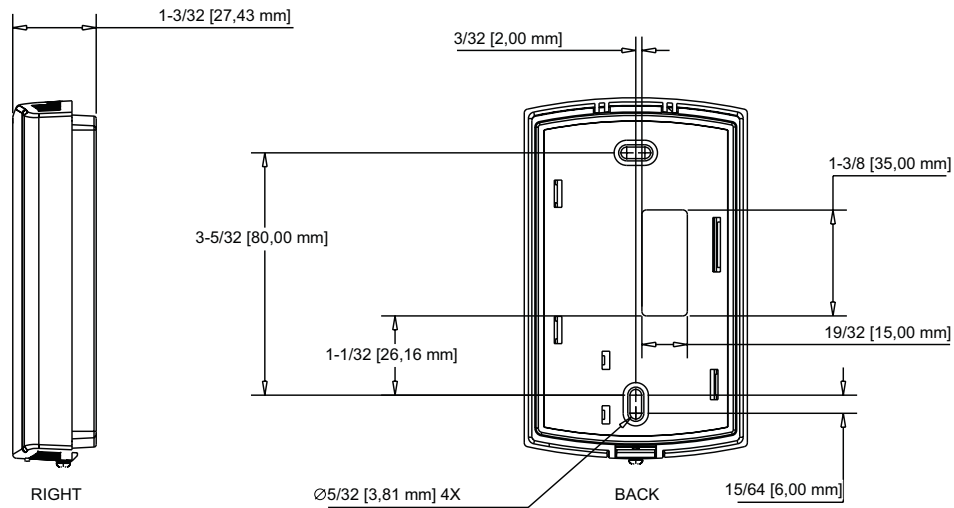

**Figure I-PR-22. Zone sensor mounting hole locations for: BAYSENS077, BAYSENS073, BAYSENS074, BAYSENS108, and BAYSENS110.**

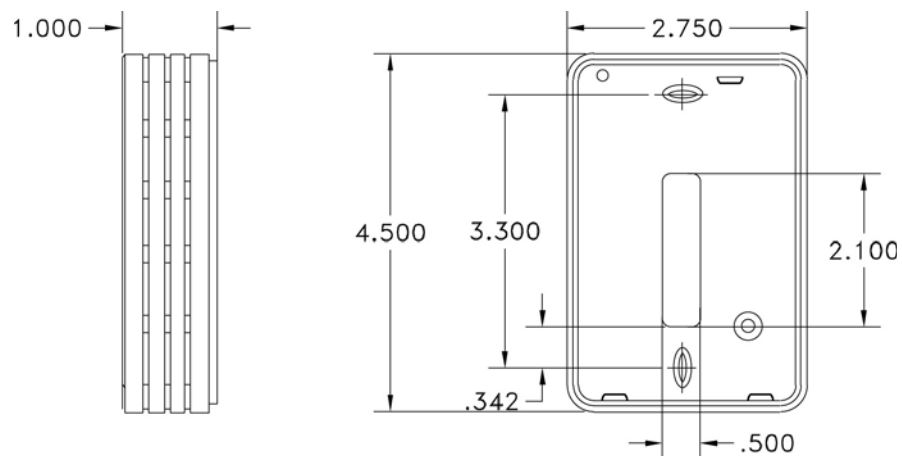

**Zone sensor mounting hole locations for: BAYSENS021.**

# Installation

## pre-startup requirements

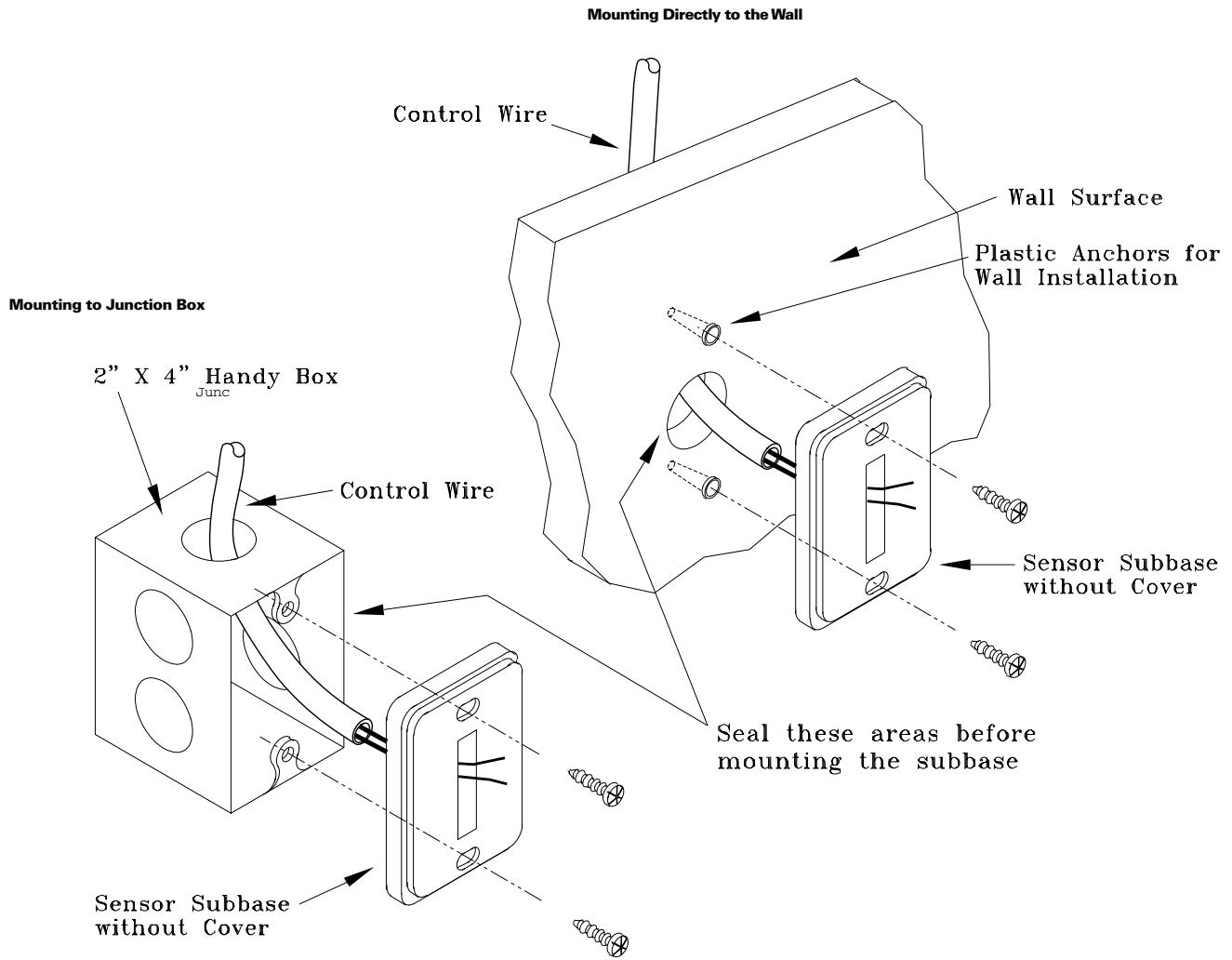

Figure I-PR-23. Typical zone sensor installation for vertically-oriented sensors



## pre-startup requirements

# Installation

### Programmable Zone Sensors

Programmable zone sensors provide programming and zone temperature sensing for the self-contained unit. It allows the user to monitor room temperatures and program settings in the space, without having to access the unit control panel.

Reference programming instructions for these zone sensors beginning on page 44.

#### Constant Volume Zone Sensor

##### BAYSENS019 Description

This seven day programmable sensor with night setback has four periods for occupied/unoccupied programming per day. If power is interrupted, the program retains in permanent memory. If power is off longer than two hours, only the clock and day may have to be reset.

The six programming keys on the front of the zone sensor allow selection of system modes (heat, cool, auto, and off), two fan modes (on and auto). The zone sensor has dual temperature selection with programmable start time capability. The occupied cooling setpoint range is 40 to 80°F. The warmup setpoint range is 50 to 90°F with a 2° deadband. The unoccupied cooling setpoint range is 45 to 98°F. The heating setpoint range is 43 to 96°F.

Two liquid crystal displays (LCD) display zone temperature, setpoints, week day, time, and operational mode symbols.

The DIP switches on the subbase enable or disable applicable functions; i.e. morning warmup, economizer minimum CFM override during unoccupied status, Fahrenheit or Centigrade, supply air tempering, remote zone temperature sensor, 12/24 hour time display, smart fan, and computed recovery.

During an occupied period, an auxiliary relay rated for 1.25 amps @ 30 volts AC with one set of single pole double throw contacts activates.



**Figure I-PR-16. BAYSENS019, programmable night setback sensor, accessory model number digit 6 = G**

#### Variable Air Volume Zone Sensor

##### BAYSENS020B Description

This seven day programmable sensor with night setback has four periods for occupied/unoccupied programming per day. Either one or all four periods can be programmed. If power is interrupted, the program retains in permanent memory. If power is off longer than two hours, only the clock and day may have to be reset.

The zone sensor keypad allows you to select occupied/unoccupied periods with two temperature inputs (cooling supply air temperature and heating warmup temperature) per occupied period. The occupied cooling setpoint ranges between 40 and 80°F. The warmup setpoint ranges between 50 and 90°F with a 2° deadband. The unoccupied cooling setpoint ranges between 45 and 98°F. The heating setpoint ranges between 43 and 96°F.

The liquid crystal display (LCD) displays zone temperature, setpoints, week day, time, and operational mode symbols.

The DIP switches on the subbase enable or disable applicable functions; i.e. morning warmup, economizer minimum position override during unoccupied status, heat installed, remote zone temperature sensor, 12/24 hour time display, and daytime warmup. During an occupied period, an auxiliary relay rated for 1.25 amps @ 30 volts AC with one set of single pole double throw contacts activates.



**Figure I-PR-17. BAYSENS020, programmable night-setback sensor, accessory model number digit 6 = J**

## Installation

### Programmable Zone Sensor Installation

#### Mounting Location

Mount the sensor on the wall in an area with good air circulation at an average temperature. Choose a location that is easily accessible, and on a wall where the subbase can be mounted about 5 feet (1.5 meters) above the floor.

Avoid mounting space temperature sensor in areas subject to the following conditions:

- Drafts or “dead” spots behind doors or in corners
- Hot or cold air from ducts
- Radiant heat from the sun or appliances
- Concealed pipes and chimneys
- Unheated or non-cooled surfaces behind the sensor, such as outside walls
- Airflows from adjacent zones or other units

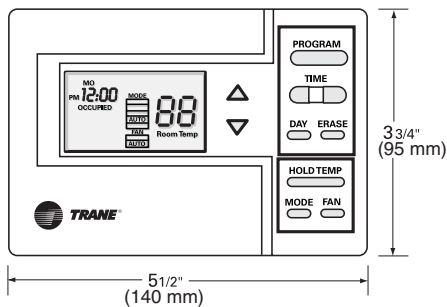

Figure I-PR-18. BAYSENS019 dimensions

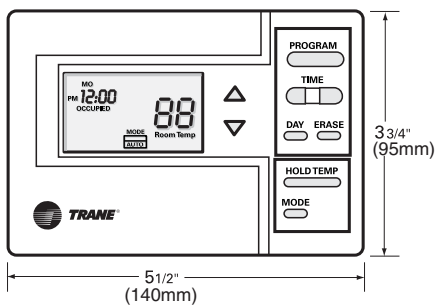

Figure I-PR-19. BAYSENS020 dimensions

#### Installation Procedure

1. Remove the zone sensor module from the subbase. Carefully hold the zone sensor module with one hand and firmly grasp the subbase with the other. See Figure I-PR-20. To remove the zone sensor module from the subbase, gently pull away and upward.

Note: The zone sensor module is an electronic sensitive device. Do not touch printed circuit board, electronic components, or connector pins. Handle plastic housing only to prevent damage to electronic components.

2. After disassembly, protect the internal surfaces from contact with objects or substances that could cause damage.
3. Remove the terminal block from subbase and set aside for wiring. Discard the tape.
4. Mount the zone sensor module using the mounting hardware included in the shipping package. The mounting hardware is contained in single plastic bag and includes:
  - Plastic wall anchors (3 x)
  - Mounting screws (3 x)
 The zone sensor module can mount directly to a wall or to a junction box mounted to a wall. To mount to a junction box, you must have the mounting plate and adapter kit, BAYMTPL003. Installation instructions are enclosed with the mounting plate.
5. To mount the zone sensor module directly to a wall:

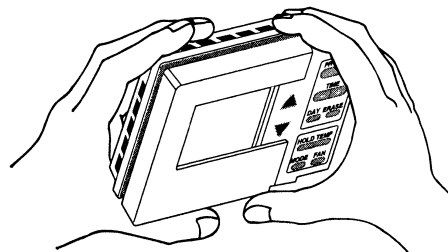

Figure I-PR-20. Removing the zone sensor module from the subbase

- a. Hold the subbase in position and mark the three mounting hole locations on the wall.
- b. Drill three  $\frac{3}{16}$ " (4.8 mm) holes. Gently tap the plastic wall anchors into the holes until the anchor tops are flush with the wall.
6. Pull the zone sensor module wires through the subbase as shown in Figure I-PR-21.
7. Loosely secure subbase to the wall with the mounting screws. Do not tighten the subbase screws yet.
8. Level the subbase by sight, then firmly tighten the three subbase mounting screws.

Note: Do not overtighten the subbase screws. Overtightening may cause the screws to crack the subbase.

9. Before wiring the subbase, identify the wires from the unit's low voltage terminal strip. Each screw terminal is labeled.
10. Remove TB from subbase and discard the tape.
11. Strip the wires  $\frac{1}{4}$ " and connect the wires from the unit's low voltage terminal strip to the zone sensor module subbase. Reference connection details on the unit wiring diagrams, located on the unit.
12. Firmly tighten each screw terminal.
13. Fit the wires as close to the subbase as possible.

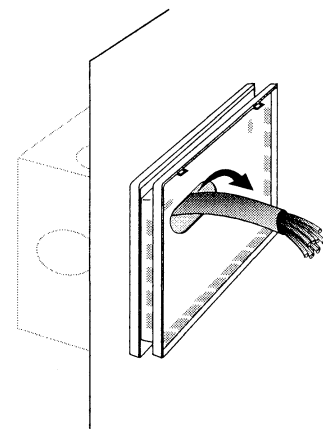

Figure I-PR-21. Securing the subbase

## pre-startup requirements

# Installation



Figure I-PR-22. Grasslin time clock option

### Time Clock Option

The time clock option has a programmable timer that is factory wired to the unoccupied input to provide on/off control. The time clock will not allow the unit to pass through the night setback/morning warmup mode, except on units with optional night heat/morning warm up, or programmable night setback. See Figure I-PR-22.

The timeclock, a "Digi 20" by Grasslin, is inside the control panel, but accessible with the control panel door closed. This same type timer is also used for programmable night setback/morning warm up. Programming instructions for the "Digi 20" timer are in the "Programming" section.

#### Time Clock Installation

1. Ensure operating temperature is between 4°F and 131°F.
2. Locate the time clock at least 5 feet away from any large electrical contact or machinery to avoid possible electrical interference problems.
3. Provide a separate independent circuit for the time clock power supply.
4. Since all electronic instruments are sensitive to voltage spikes, pay close attention to the following:
  - a. If possible, supply power to the electronic time clock from a phase different than the one supplying power to the load.
  - b. Provide a suitable Varistor or RC network across the INDUCTIVE LOADS supply terminals to reduce voltage spikes.
  - c. Place a diode across the DC OPERATED INDUCTOR terminals to eliminate back EMF.
  - d. HIGHLY INDUCTIVE LOADS, especially fluorescent lights, may require a relay in which case step a. and c. apply.

The timeclock can be surface or flush mounted. Lift off the front cover and loosen the two screws on opposite corners. Pull off the base's plug with a left to right rolling motion.

#### Time Clock Installation Checklist

1. Ensure operating temperature is 4°F to 131°F.
2. Locate the time clock at least 5 feet away from any large electrical contact or machinery to avoid possible electrical interference problems.
3. Provide a separate independent circuit for the time clock power supply.
4. Since all electronic instruments are sensitive to voltage spikes, pay close attention to the following:
  - a. If possible, supply power to the electronic time clock from a phase different than the one supplying power to the load
  - b. Provide a suitable Varistor or RC network across the INDUCTIVE LOADS supply terminals to reduce voltage spikes.
  - c. Place a diode across the DC OPERATED INDUCTOR terminals to eliminate back EMF.
  - d. HIGHLY INDUCTIVE LOADS, especially fluorescent lights, may require a relay in which case (A) and (C) apply.

The Digi 20A timeclock unit can be surface or flush mounted. Lift off the front cover and loosen the two screws on opposite corners. Pull off the base's plug with a left to right rolling motion.

#### Surface Mounting Inside Panel

Place screws through the base's preset holes and screw to back of panel or wall.

Wire according to the instructions in the following section. Depending upon the specific installation, you may find it more convenient to complete wiring before attaching the base.

Place the terminal cover over the terminal block by aligning the two screws with the corner holes in the base. Push the timer firmly onto the plug in the base. Tighten the two screws. A base for DIN rail mounting is optional.

#### Wiring the Timeclock

1. Wire 24, 120, or 220 VAC to input terminals. Make sure to apply correct voltage. Using incorrect voltage will void the warranty.
2. Connect wire to the screw terminals according to the unit wiring diagrams. Use 12 to 22 AWG wire.

# Installation

## pre-startup requirements

### Remote Human Interface Panel Installation

#### Human Interface (HI) Panel

The HI enables the user to communicate necessary unit operating parameters and receive operating status information from within the occupied space.

The HI displays top level information in the LCD window, unless the operator initiates other displays, for the various unit functions. It also displays menu readouts in a clear language 2 line, 40 character format. The 16-key keypad allows the operator to scroll through the various menus to set or modify the operating parameters. See Figure I-PR-23 to reference the HI keypad.

#### Remote Human Interface Panel

The remote human interface (RHI) panel is identical to the unit mounted HI with the exception of the "unit select" key. This key allows the operator to switch from one unit to the next to program or view status information regarding a particular unit.

The RHI functions the same as the unit mounted HI with two exceptions. The first is the "test start" function. The operator can view the service parameters, but can only initiate the service test function at the unit. The RHI door has a locking screw to deter access by unauthorized personnel. Additionally, the RHI can control up to four different units.

#### Location Recommendations

The HI microprocessor module is mounted inside a molded plastic enclosure for surface mounting. It is not weatherproof. Therefore, it is only applicable for indoor use.

Locate the RHI panel in an area that will ensure the communication link between the panel and the unit(s) does not exceed 5,000 feet maximum or pass between buildings. See Table I-PR-2.

The run length of the low voltage AC power wiring to the remote HI must not exceed three (3) ohms/conductor. Refer to Table I-PR-3.

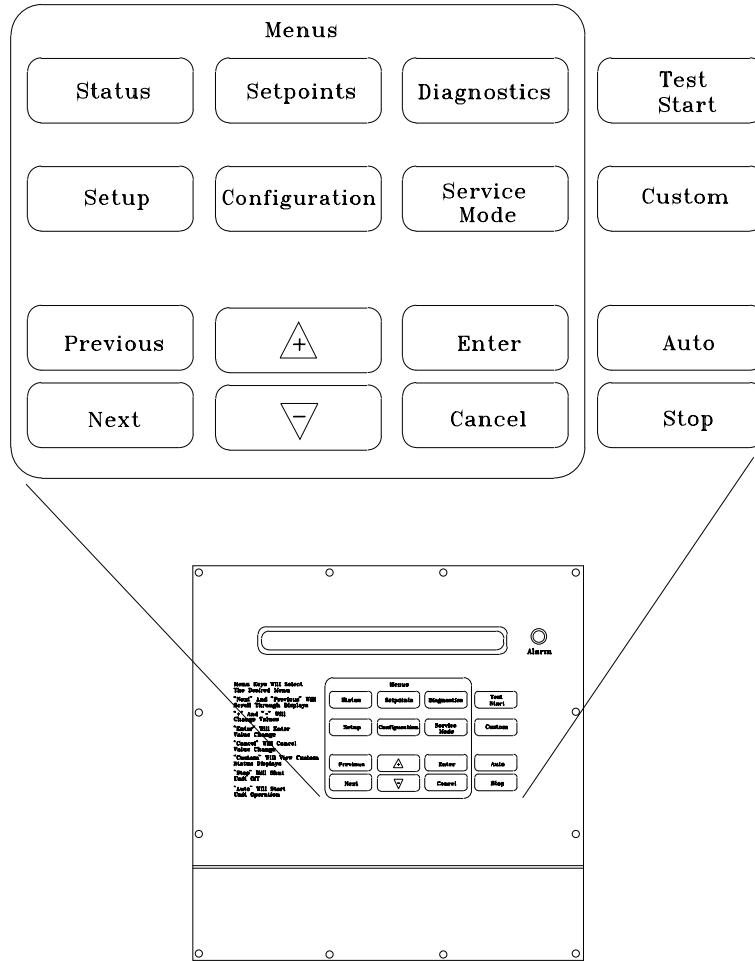

Figure I-PR-23. Human interface (HI) panel keypad

Table I-PR-2. Maximum communication link wiring length

max. wire length	max. capacitance between conductors
1,000 ft	up to 60 pF/ft
2,000 ft	up to 50 pF/ft
3,000 ft	up to 40 pF/ft
4,000 ft	up to 30 pF/ft
5,000 ft	up to 25 pF/ft

Note: pF/ft = picofarads/foot

#### Ambient Temperature and Humidity Limits

##### Ambient Operating Conditions

- Temperature: 32 to 120°F
- Relative humidity: 10 to 90%, non-condensing

##### Ambient Storage Conditions

- Temperatures: -50 to 200°F
- Relative humidity: 5 to 95%, non-condensing

Table I-PR-3. Wiring recommendations for the remote HI panel

distance to remote HI	recommended wire size
0-460 feet	18 gauge
461-732 feet	16 gauge
733-1000 feet	14 gauge

## Installation

### Mounting the Remote Human Interface (RHI) Panel

The installer must provide all mounting hardware such as; hand tools, electrical boxes, conduit, screws, etc. Refer to Figure I-PR-24 for the mounting hole and knockout locations.

#### Procedure

Refer to Figure I-PR-24 and follow the procedure below for mounting the remote HI panel on a 4" by 4" electrical junction box. Place the microprocessor in a clean dry location during the enclosure mounting procedures to prevent damage.

1. Mount an electrical junction box in the wall so that the front edge of the box will be flush with the finished wall surface.
2. Prior to mounting the panel, the microprocessor module must be carefully removed from the enclosure. To remove the module:
  - a. Lay the remote panel face up on a flat surface and remove the locking screw from the right hand bottom end of the panel.
  - b. Remove the recessed hinge screw from the left hand bottom end of the panel.
  - c. Unlatch the door of the enclosure as if to open it, and slide the left hand side of the door upward away from the hinge. Lay it aside.
  - d. With the key pad visible, remove the two (2) screws located on the right hand side of the key pad.
  - e. Carefully slide the key pad plate upward from the bottom, releasing the extruded hinge pin from its socket at the top.
  - f. Set the microprocessor aside until mounting is complete.
3. Remove the junction box knockout in the back of the enclosure.

---

Note: The top of the enclosure is marked "TOP:"

---

4. With the enclosure in the correct position; align the mounting holes around the knockout in the enclosure with the screw holes in the electrical handy box and secure with the appropriate screws.
5. Replace the microprocessor within the enclosure as follows:

- a. Verify that the terminal block jumpers are connected properly.
- b. Slide the extruded hinge pin at the top left of the key pad plate into the hole located at the top left hand side of the enclosure.
- c. Slide the bottom of the plate into place, aligning the two (2) clearance holes with the screw holes on the right. Install the screws but do not tighten.

---

Note: If the two screws are not installed as called out in the previous step, hold against the key pad plate while installing the door in the next step, to prevent it from falling out.

---

- d. Slide the extruded hinge pin at the top left of the door into the hole located under the bottom left side of the display.
- e. Install and tighten the hinge screw located at the bottom left side of the enclosure.

#### Wall Mounting the RHI Panel

1. Prior to mounting the panel, the microprocessor module must be removed from the enclosure. Complete step 2 in the previous discussion, "Mounting on a 4 in. x 4 in. Electrical Box," before proceeding.
2. With the microprocessor removed, refer to Figure I-PR-24 for the location of the mounting holes to be used for wall mounting.
3. Place the enclosure against the mounting surface and mark the mounting holes.

---

Note: The top of the enclosure is marked with "TOP:"

---

4. With the enclosure in the correct position, remove the enclosure and drill the necessary holes in the surface for the appropriate fasteners, (plastic anchors, molly bolts, screws, etc.)
5. Remove the necessary knockouts for the wire or conduit entry before mounting the panel.
6. Place the enclosure back onto the surface and secure it with the appropriate screws.
7. Follow step 5 in the previous section, "Mounting on a 4" by 4" Electrical Box," to replace the microprocessor within the enclosure.

# Installation pre-startup requirements

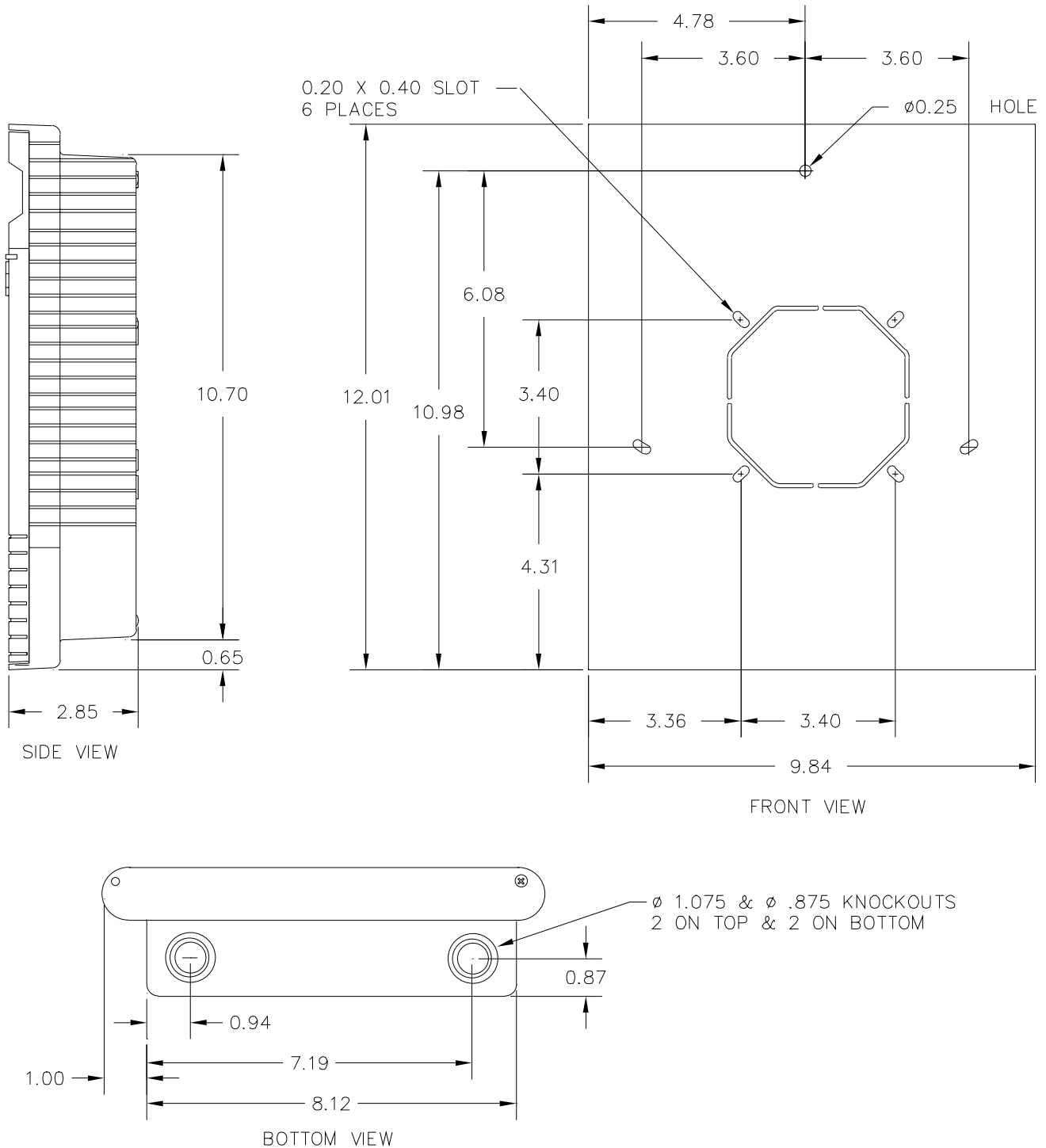

Figure I-PR-24. Remote HI mounting holes and knockout locations

## pre-startup requirements

# Installation

### Wiring the Remote Human Interface

The remote human interface requires 24 VAC  $\pm$  4 volts power source and a shielded twisted pair communication link between the remote panel and the interprocessor communication bridge (ICPB) module at the self-contained unit.

Field wiring for both the low voltage power and the shielded twisted pair must meet the following requirements:

Note: To prevent control malfunctions, do not run low voltage wiring (30 volts or less) in conduit with higher voltage circuits.

### **⚠**WARNING

#### Hazardous Voltage w/Capacitors!

Disconnect all electric power, including remote disconnects before servicing. Follow proper lockout/tagout procedures to ensure the power cannot be inadvertently energized. For variable frequency drives or other energy storing components provided by Trane or others, refer to the appropriate manufacturer's literature for allowable waiting periods for discharge of capacitors. Verify with an appropriate voltmeter that all capacitors have discharged. Failure to disconnect power and discharge capacitors before servicing could result in death or serious injury.

Note: For additional information regarding the safe discharge of capacitors, see PROD-SVB06A-EN or PROD-SVB06A-FR.

1. All wiring must be in accordance with NEC and local codes.
2. Reference Table I-PR-3 for recommended wiring distance and size.
3. Communication link wiring must be 18 AWG shielded twisted pair (Belden 8760, or equivalent).
4. Communication link must not exceed 5,000 feet maximum for each link. See Table I-PR-2.
5. Do not run communication link between buildings.

### Low Voltage (AC) Field Wiring Connections

To access the wire entry locations, open the RHI panel door and remove the two screws on the right-hand side of the key pad. Swing the keypad open, exposing both the wire entries and the back of the HI module. Refer to Figure I-PR-24 and connect one end of the three conductor 24 volt wires to the remote panel terminal strip (+), (-), and (ground).

### Communication Link (Shielded Twisted Pair) Wiring

Trim the outer covering of the shielded cable back approximately 1 inch. See Figure I-PR-25. **Do not** cut the bare shield wire off. Strip approximately 1/2-inch of insulation from each insulated wire to connect them to the terminal strip at the remote panel.

Connect the white lead to the positive (+) terminal, the black lead to the negative (-) terminal, and the bare shield wire to the terminal at the remote human interface panel.

Close the key pad plate. Install and tighten the two screws removed earlier. Close the outer door and install the recessed locking screw at the bottom right hand side of the enclosure to prevent accidental starting of the unit by unauthorized personnel while completing the wiring at the self-contained unit.

### At the Self-Contained Unit

Connect the opposite end of the three conductor 24-volt wire to the appropriate terminal strip as follows:

Note: Although the 24 volt power is not polarity sensitive, do not connect either the + (plus) or - (minus) terminals from the remote panel to ground at the self-contained unit.

Connect the wire connected to the positive (+) terminal at the remote panel. Connect the wire connected to the negative (-) terminal at the remote panel. Connect the ground wire from the remote panel to the unit control panel casing.

### Interprocessor Communication Bridge Module Wiring

Refer to Figure I-PR-25 and trim the outer covering of the shielded cable back approximately one inch. Cut the bare shield wire off even with the outer covering. Strip approximately 1/2-inch of insulation from each insulated wire in order to connect them to the terminal strip at the unit. Wrap tape around any exposed foil shield and/or base shield wire.

Note: The communication link is polarity sensitive.

Refer to the unit wiring diagram and connect the white lead to the positive (+) terminal and the black lead to the negative (-) terminal. (These terminals are numbered. Reference to color is for clarification to maintain polarity).

Note: To maintain polarity, do not connect the base shield wire to ground at the self-contained unit.

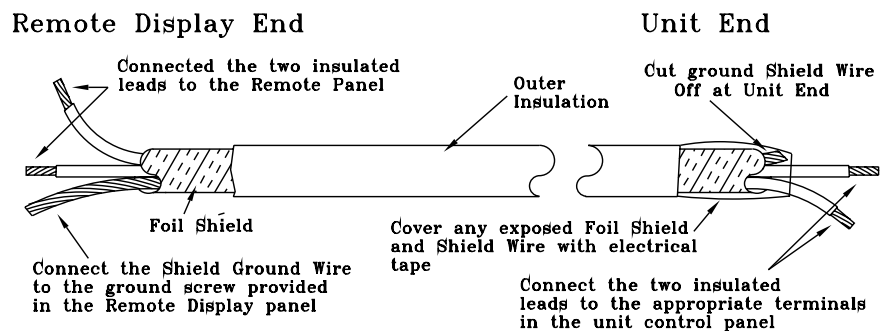

Figure I-PR-25. Dressing shielded twisted wire



## pre-startup requirements

# Installation

## Connecting to Tracer Summit

### **⚠ WARNING**

#### **Hazardous Voltage w/Capacitors!**

Disconnect all electric power, including remote disconnects before servicing. Follow proper lockout/tagout procedures to ensure the power cannot be inadvertently energized. For variable frequency drives or other energy storing components provided by Trane or others, refer to the appropriate manufacturer's literature for allowable waiting periods for discharge of capacitors. Verify with an appropriate voltmeter that all capacitors have discharged. Failure to disconnect power and discharge capacitors before servicing could result in death or serious injury.

**Note:** For additional information regarding the safe discharge of capacitors, see PROD-SVB06A-EN or PROD-SVB06A-FR.

IntelliPak commercial self-contained (CSC) units operate with Trane building automation software, Tracer Summit version 10.0.4 or later or any OS2 operating system.

Note: Tape the non-insulated end of the shield on shielded wire at the unit. Any connection between the shield and ground will cause a malfunction. If daisy-chained in the unit, splice and tape the shields to prevent contact with ground.

### **Communication Wiring**

Note: Communication link wiring is a shielded, twisted pair of wire and must comply with applicable electrical codes.

An optional communication link provides a serial communication interface (SCI) between Tracer Summit and each commercial self-contained (CSC) unit in the system. The CSC system can have a maximum of 12 CSC units per connection link to Tracer Summit. Use a single 18 AWG shielded, twisted pair wire with stranded, thinned copper conductors to

establish each communication link between Tracer Summit and each unit.

### **Pre-Startup Checklist**

Complete this checklist after installing the unit to verify all recommended installation procedures are complete before unit start-up. This does not replace the detailed instructions in the appropriate sections of this manual. Always read the entire section carefully to become familiar with the procedures.

#### **Receiving**

- Inspect unit and components for shipping damage. File damage claims immediately with the delivering carrier.
- Check unit for missing material. Look for ship-with drives, isolators, filters, and sensors that are packaged separately and placed inside the main control panel, fan section, or compressor section. See the "Receiving and Handling" section.
- Check nameplate unit data so that it matches the sales order requirements.

#### **Unit Location**

- Remove crating from the unit. Do not remove the shipping skid until the unit is set in its final position.
- Ensure the unit location is adequate for unit dimensions, ductwork, piping, and electrical connections.
- Ensure access and maintenance clearances around the unit are adequate. Allow space at the end of the unit for shaft removal and servicing. See the "Service Access" section.

#### **Unit Mounting**

- Place unit in its final location.
- Remove shipping skid bolts and skid.
- If using isolators, properly mount unit according to the isolator placement sheet.
- Remove shipping brackets on the compressors and supply fan.
- Remove the unit protective shipping covers.

#### **Component Overview**

- Verify the fan and motor shafts are parallel.
- Verify the fan and motor sheaves are aligned.
- Check the belt tension for proper adjustment.
- Ensure the fan rotates freely.

- Tighten locking screws, bearing set screws and sheaves.
- Ensure bearing locking collars do not wobble when rotated.

#### **Ductwork**

- If using return ductwork to the unit, secure it with three inches of flexible duct connector.
- Extend discharge duct upward without change in size or direction for at least three fan diameters.
- Use a 3" flexible duct connection on discharge ductwork.
- Ensure trunk ductwork to VAV boxes is complete and secure to prevent leaks.
- Verify that all ductwork conforms to NFPA 90A or 90B and all applicable local codes

#### **Water-Cooled Unit Piping**

- Verify the condensate drain piping is complete for the unit drain pan. Install and tighten the condensate "P" trap drain plug.
- Install water piping drain plugs, economizer header, and condenser vent plugs.
- Make return and supply water connections to the unit and/or waterside economizer piping package with recommended valves and piping components. Refer to the "Water Piping" section.
- Install unions to allow waterside maintenance.
- Install cooling tower and standby pumps.
- Treat water to prevent algae, slime, and corrosion.
- Prevent refrigerant piping from rubbing against other objects.

#### **Air-Cooled Units Only**

- Connect refrigerant lines.
- Install liquid line filter driers.

#### **Units with Hydronic Heat**

- Verify the entering water temperature sensor is installed upstream of the hydronic coil.

#### **Units with Electric Heat**

- Verify the supply air temperature sensor is downstream of the electric heat coil.



# Installation programming

## Programmable Zone Sensor Options BAYSENS019

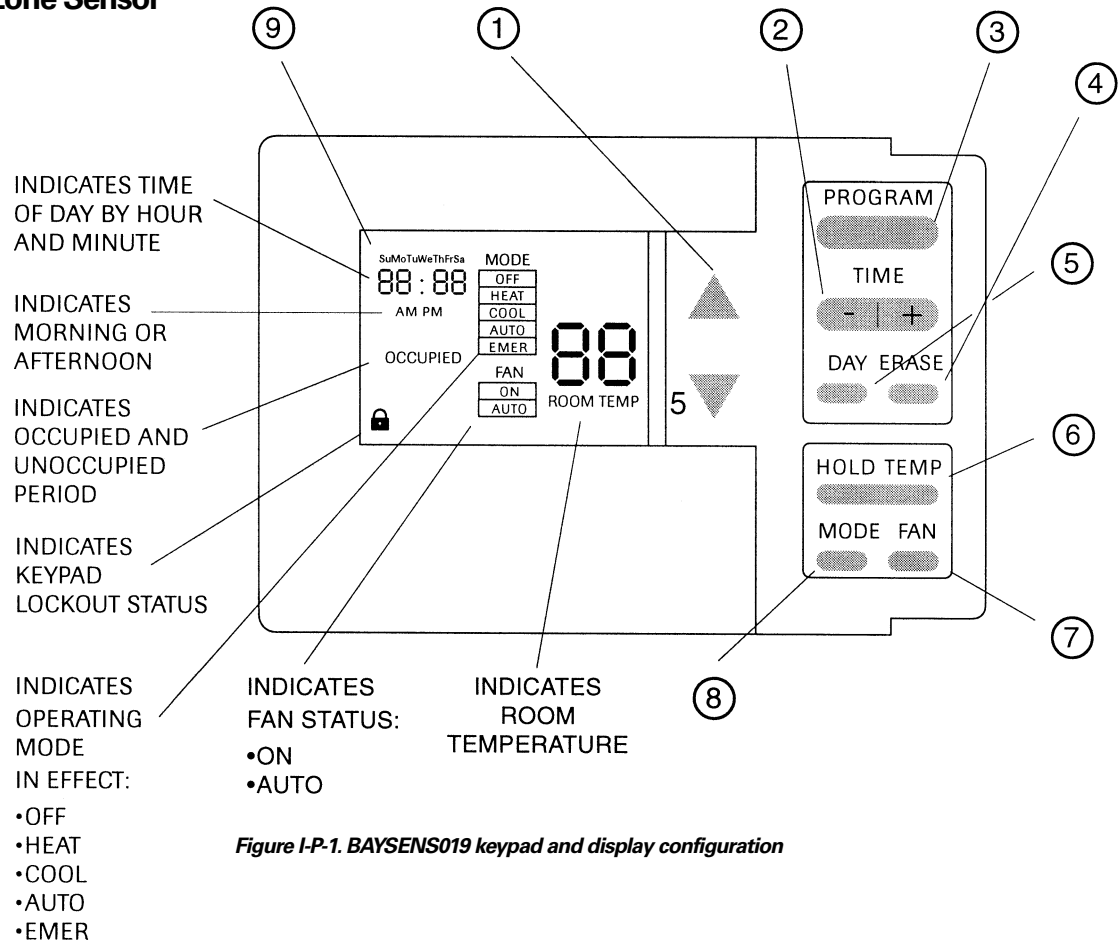

Figure I-P-1. BAYSENS019 keypad and display configuration

### BAYSENS019 Keypad and Display Explanation

#### 1. Up and Down Buttons

- Increases or decreased programmed temperature settings in program menu.
- Shifts to temporary manual override in normal run mode.
- Increases or decreases temperature while in temporary override menu.

#### 2. Time Adjust Button

Used to set the correct time of day. Used to set programmed time for temperature variations.

#### 3. Program Button

Toggles between the display control screen and the display program screen.

#### 4. Erase Button

- Erases time and temperature settings throughout each of the programmed periods.
- Exits temporary manual override.

#### 5. Day Button

Toggles through the seven days of the week.

#### 6. Hold Temp Button

Shifts controller to temporary manual override, and begins temperature override.

#### 7. Fan Button

Toggles the fan controller between on and auto mode.

#### 8. Mode Button

Toggles the controller through its 4 modes: off, heat, cool, and auto; if HP version, also emer (emergency).

#### 9.

- Indicates day of the week
- Indicates begin time in program menu
- Indicates time setting in temporary override mode.

# Installation programming

## BAYSENS020

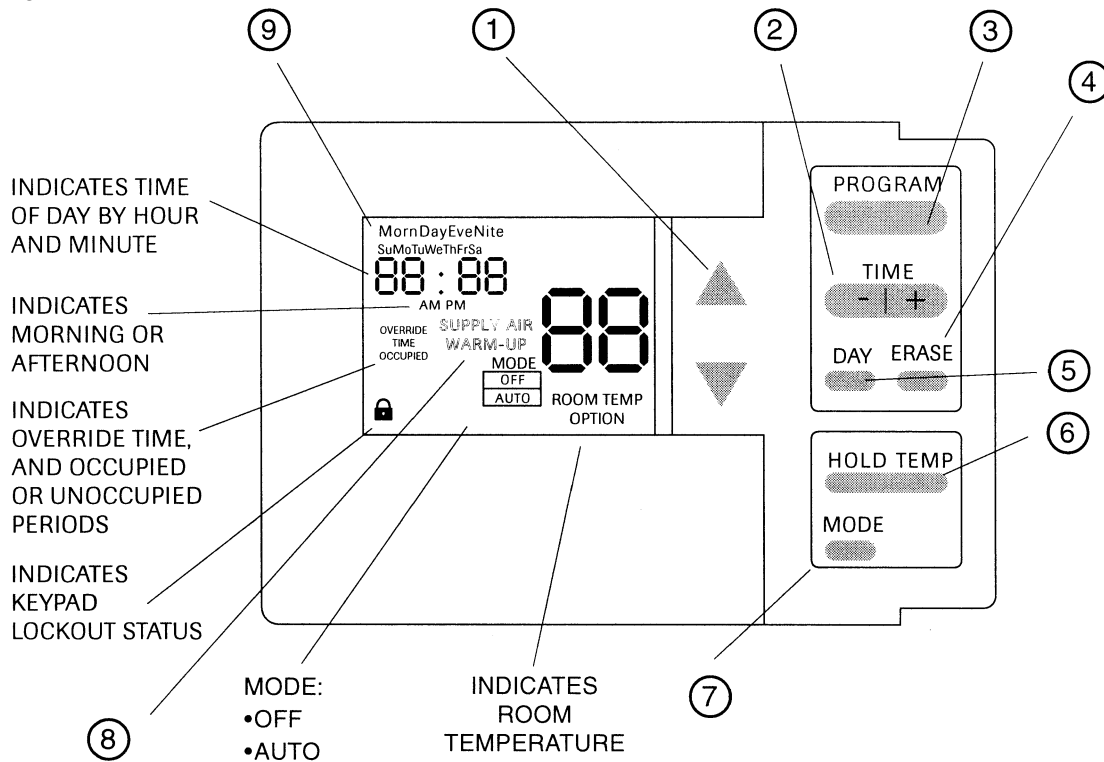

Figure I-P-2. BAYSENS020 keypad and display configuration

### BAYSENS020 Keypad and Display Explanation

#### 1. Up and Down Buttons

- Increases or decreased programmed temperature settings in program menu.
- Shifts to temporary manual override in normal run mode.
- Increases or decreases temperature while in temporary override menu.
- Pressed together, toggles between unoccupied/occupied setting.

#### 2. Time Adjust Button

Used to set the correct time of day. Used to set programmed time for temperature variations.

#### 3. Program Button

Toggles between the display control screen and the display program screen.

#### 4. Erase Button

- Erases time and temperature settings throughout each of the programmed periods.
- Exits temporary manual override.

#### 5. Day Button

Toggles through the seven days of the week.

#### 6. Hold Temp Button

Shifts controller to temporary manual override, and begins temperature override.

#### 7. Mode Button

- Toggles the controller between the two modes, off and auto.
- Advances to next setpoint in program menu.

#### 8. During Programming Indicates:

- Heat supply air
- Cool supply air
- Warmup temperature

# Installation

# programming

## Initial Power-Up

Before applying power to your ZSM, and before performing setup and operation procedures, verify that all wiring is correct. See Figures I-P-9 on page 52 and I-P-10 on page 53 for a complete zone sensor icon display description.

For BAYSENS020 only: at initial power-up, the ZSM controls to default temperatures of 68°F (19°C) for warmup, and 55°F (13°C) supply air, until the ZSM is programmed or the arrow keys are pressed. If the arrow keys and mode are moved, the ZSM starts controlling to these new settings.

## Time and Day Settings

On power-up your ZSM will be in normal run mode and will begin operating using setpoints. The display will show the wrong day and time and will need to be set.

To set the time, there is a single rubber button on the keypad “minus” and “plus” mark time.

Depressing the positive side will advance the time. Depressing the negative side will decrease the time.

Each time you depress the positive or negative side “minus” and “plus”, the time will either advance or decrease respectively by one minute. If you press and hold either side of the time button, the time change will accelerate rapidly.

When you reach the correct time, release the time button and the time will be set into permanent memory.

Note: To ensure the time changes are made, the ZSM will initiate a 30 second user-stabilization time before making changes to the ZSM operation mode.

## Keypad Operation

Note: After toggling to the program screen, the week is divided into seven days with each day divided into four periods. Therefore, 28 program settings are possible.

## Program Button

Depressing the program button will toggle the display from normal run mode to the program menu. See Figure I-P-3. Before toggling to the program menu, use the mode button to select the type setpoints to review or program (heat, cool or auto). For example, if you select cool mode before toggling to the program menu, then only the cool setpoints are reviewed or programmed. If you select heat mode, then only the heat setpoints are reviewed or programmed. In auto mode, both heat and cool setpoints are reviewed and programmed.

- While in program menu, each time you press and release the program button, the ZSM toggles through the four periods that divide each day. Those four periods are: Morn(ing), Day, Eve(ning), and Night.
- To exit the program menu, depress the program button for two seconds.

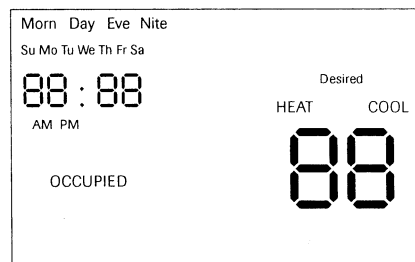

Figure I-P-3. Display program menu screen

## Program Menu

### BAYSENS020 Only

Note: After toggling to the program screen, the week is divided into seven days with each day divided into four periods.

Setpoint programming depends on the setting status, occupied or unoccupied, and whether or not heat is installed, modulated heat, morning warmup, or daytime warmup options are enabled.

In the occupied period, the cool supply air temperature is always set. If heat installed and modulated heat options are on, the supply air heat is also set during occupied periods. The warmup temperature is also set in occupied periods, if heat

is installed and warmup options are enabled.

During unoccupied periods, only the desired room temperature setpoints are entered. Each unoccupied period has a heat and cool setpoint, and both setpoints are offered during programming.

Blank temperature settings may also be entered. When a setpoint is blank, the program will default to the last setpoint of its type. If there is no setpoint of its type, the default setpoint is used. If all setpoints in the time period are blank, the entire time period is erased after exiting from the program menu.

## The ZSM has independent, seven day programming:

- Each day can be programmed with different times, temperatures, and occupied status.
- Each day can be programmed with up to four periods. Although four periods are available each day, you can program just one of the four.
- Each period can be programmed for occupied or unoccupied.

## To begin programming, follow these steps:

- Determine which periods during the day will be occupied and unoccupied.
- Write your daily schedule on the sheet enclosed with the zone sensor.
- Enter your program by following the steps below.

## To program time periods and setpoints for a day:

- Press the program button to enter program mode.
- Press the day button to select first day to be programmed.
- To set the “begin” time for the first period of the day, press the minus or plus keys.
- To set the temperature setpoint for that period, use ↑ or ↓.
- Press the program button to move to the next period for that day.
- To program time periods and setpoints for the next day, press the day button.
- When finished, press and hold the program button for two seconds to return to the normal run mode.

# Installation

# programming

Note: Blank temperature settings may be entered at any of the four daily periods. When a setpoint is left blank and in an occupied condition, the ZSM will default to the last occupied setpoint. When a setpoint is left blank and in an unoccupied condition, the ZSM will default to the last unoccupied setpoint.

### Temporary Manual Override

While in normal run mode, depressing the hold temp button toggles the ZSM to the temporary manual override menu.

The mode will override any number of programmed setpoints through any of the 28 programmed periods. After entering setpoints and length of override time, these new settings are used in place of the setpoints programmed for normal run mode.

### Time Button

- While in the program menu, each time you press and release the positive or negative side of the time button, the time will advance or decrease by ten minute increments. If you press and hold the positive or negative side ("minus" and "plus" keys), the ZSM will increment rapidly.
- When the display is in the normal run mode, each time you press and release the positive or negative side of the time button ("minus" and "plus" keys), the time will advance or decrease by one minute. If you press and hold the positive or negative side ("minus" and "plus" keys), the ZSM will increment rapidly.

Note: Blank temperature settings may be entered at any of the four daily periods. When a setpoint is left blank and in an occupied condition, the ZSM will default to the last occupied setpoint.

### Keypad Lockout

If you simultaneously depress and hold both the positive and negative sides of the "minus" and "plus" keys for four seconds, the lock icon will appear and all keypad functions will lock out. If you repeat this operation, the lock icon will disappear and all keypad functions will be available again.

- Keypad lockout applies only to normal run mode and temporary manual override mode.

### Day Button

- In normal run mode, depressing the day button will move the current day ahead.
- While in the program menu, depressing the day button will move you through the seven days of the week and allow you to program temperature settings for each of the four daily periods.

### Erase Button

- Pressing the erase button while in normal run mode will turn off the check filter icon.
- Pressing the erase button while in the program menu, will erase all time and temperature setpoints of a given period.
- The erase button will acknowledge the failure buzzer (option 16) until 12:00 am.

### Mode Button

- BAYSENS019 only: Pressing the mode button toggles through all modes: off, heat, cool, auto, and emer (HP unit).
- BAYSENS020 only: Pressing the mode button while in normal run mode, or temporary manual override run mode, will toggle through both modes, off and auto.

### Fan Button

- The fan button allows you to toggle between on and auto.

### Up and Down Button Arrows

- Depressing  $\uparrow$  or  $\downarrow$  arrow while in normal run mode will cause your ZSM to toggle to the temporary manual override menu.
- Depressing either  $\uparrow$  or  $\downarrow$  arrow while in the program menu or temporary override menu will cause the temperature setpoint to advance or decrease in one degree increments.
- Depressing and holding either the  $\uparrow$  or  $\downarrow$  arrow will cause the temperature setting to increment rapidly.

Simultaneously depressing the  $\uparrow$  or  $\downarrow$  arrow for two seconds while in the program menu or temporary override menu will toggle the ZSM between an occupied and unoccupied condition.

### Holdtemp Button

While in normal run mode, depressing the hold temp button toggles the ZSM to

a temporary manual override menu. See Figure I-P-4.

This mode overrides any number of programmed setpoints through any of the 28 programmed periods. After entering setpoints and length of override time, these settings are now used.

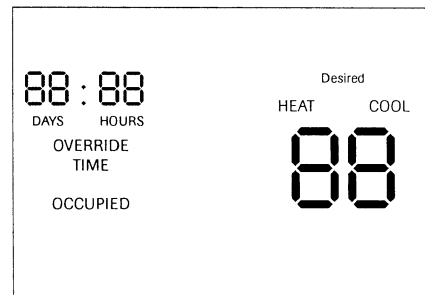

Figure I-P-4. Temporary manual override menu screen

### Keypad Operation for Temporary Manual Override Menu

The keypad has the same function in temporary manual override menu as in all other menus, with a few exceptions:

- Depressing the day button will toggle your ZSM between the day and hour icon. See Figure I-P-4.
- Depressing the mode button will toggle your ZSM between the heat and cool icons and setpoints.
- Depressing the erase button will cancel the override and return the ZSM to normal run mode.
- Depressing the holdtemp or program buttons while in the temporary manual override menu will toggle your ZSM to the temporary override mode. See Figure I-P-5.

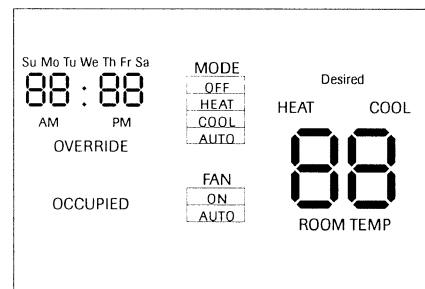

Figure I-P-5. Override run mode screen

# Installation

# programming

## Temporary Override Run Mode

The temporary override run mode sends setpoint data to the unit control module (UCM) from the setpoint data entered in the temporary manual override menu.

In temporary override run mode, most of the keypad functions lock out with these exceptions:

- The mode button still functions as in normal run mode.
- The fan button still functions as in normal run mode.
- Depressing the holdtemp button toggles the ZSM between the temporary manual override menu and override run mode. (if no button is pressed for 20 seconds while in temporary manual override menu, the ZSM exits to normal run mode, ignoring the temporary override settings.)
- Depressing either the ↑ or ↓ arrow while in the override run mode will cause the ZSM to toggle to the temporary manual override menu.
- The erase button will turn off the check filter icon if displayed.
- Simultaneously depressing and holding the positive and negative sides of the “minus” and “plus” for four seconds will lock out the keypad.
- Time is not adjustable in this mode.
- The program button is disabled.

## Keypad Operation for Temporary Manual Override Menu

The keypad has the same function in temporary manual override menu as in all other menus, with a few exceptions:

- Depressing the holdtemp or program buttons while in temporary manual override menu will enter settings and begin temporary manual override run mode. See Figure I-P-6.

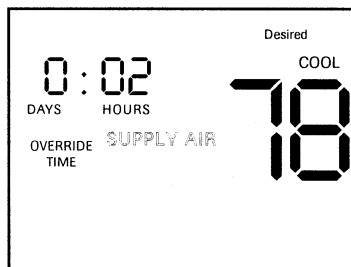

**Figure I-P-6. Temporary manual override menu screen**

- Depressing the day button will toggle the ZSM between the day and hour icon.
- Depressing the mode button will toggle the ZSM between the heat and cool icons and setpoints.
- Depressing the erase button will cancel the override and return the ZSM to normal run mode.
- If no button is pressed for 20 seconds, the ZSM exits temporary manual override menu and enters the normal run mode, ignoring the temporary manual override menu settings.

## Temporary Manual Override Run Mode

The temporary manual override run mode sends setpoint data to the UCM from the setpoint data entered in the temporary manual override menu. See Figure I-P-7.

In temporary manual override run mode, most of the keypad functions lock out with these exceptions:

- The mode button still functions as in normal run mode.
- Depressing the holdtemp button toggles the ZSM between temporary manual override menu and temporary manual override run mode. If no button is pressed for 20 seconds, while in the temporary manual override menu, the ZSM exits to the normal run mode, ignoring the temporary manual override settings.
- Depressing either the up or down arrow keys while in temporary manual override run mode will cause the ZSM to toggle to temporary manual override menu.
- The erase button will turn off the check filter icon if displayed.
- Simultaneously depressing and holding the positive and negative sides of the minus/plus key for four seconds will lock out the keypad.
- Time is not adjustable in this mode.

# Installation programming

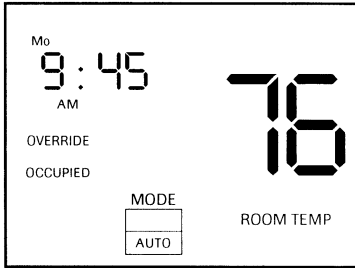

**Figure I-P-7. Temporary manual override run mode screen**

### Option Menu and Keypad Operation

The operation menu sets all programmable options built into your ZSM. All options are retained in permanent EEPROM memory.

To access the option menu display, simultaneously depress and hold the mode button and program button for four seconds.

The example in Figure I-P-8 shows option 15 displayed and indicates the initial timer setting in the temporary override run mode. The option value shown is in hours, and value selected is five hours.

When the option menu displays, the only active buttons are the  $\uparrow$  or  $\downarrow$  arrow and the "minus" and "plus" button. The  $\uparrow$  or  $\downarrow$  arrow increment through the available options by number (1-24), and the "minus" and "plus" button toggles through the various option values associated with each option number. See Table I-P-1.

Note: On both programmable zone sensor options, changing either option 9 or 10 will erase the current program. To avoid reprogramming, set options 9 and 10 before programming.

**Table I-P-1. Zone sensor BAYSENS019 option menu settings**

option	description	value	factory setting
1	morning warmup	0 = disabled 1 = enabled	0
2	economizer minimum position override	0 = disabled 1 = enabled	1
3	temperature scale	0 = Fahrenheit 1 = enabled	0
4	supply air tempering	0 = disabled 1 = enabled	0
5	time clock	0 = 12 hours 1 = 24 hours	0
6	smart fan	0 = disabled 1 = enabled	1
7	intelligent temperature recovery	0 = disabled 1 = enabled	0
8	programmable days/week	0 = 7 days (M,T,W,T,F,S,S) 1 = 3 days (M-F, S, S) 2 = 2 days (M-F, S,S)	0
9	programmable periods/day	2,3,4	4
10	programmable fan operation	0 = disallowed 1 = allowed	0
11	remote sensor installed	0 = No 1 = Yes	0
12	check filter interval	0 = disabled 3000 to 50 in 50 hour increments	350
13	display zone temperature	0 = no 1 = yes	1
14	keypad lockout enabled	0 = disabled 1 = enabled	1
15	initial time setting in temporary override mode (hrs.)	1,2,3,4,5	3
16	buzzer options	0 = key press only 1 = key press & check filter 2 = key press, check filter, and system failures	1
17	zone temperature calibration	displays current temp. with any offsets	0 offset
18	baud rate	0 = 1024 baud 1 = 1200 baud	1
19	CV or HP operation	0 = CV 1 = HP	0
20	default cooling setpoint	45 to 98°F	74°F
21	default heating setpoint	43 to 96°F	68°F
22	minimum cooling setpoint	45 to 98°F	45°F
23	maximum heating setpoint	43 to 96°F	96°F

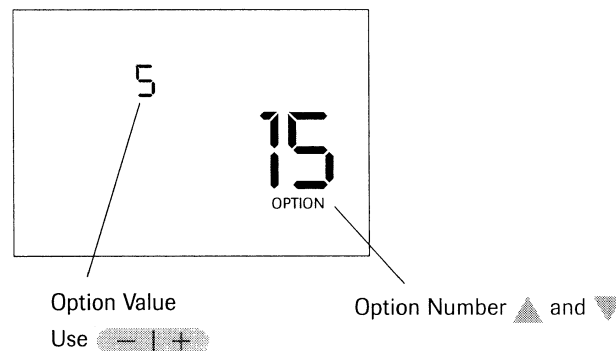

**Figure I-P-8. Typical option menu screen**

# Installation programming

Note: On both programmable zone sensor options, changing either option 9 or 10 will erase the current program. To avoid reprogramming, set options 9 and 10 before programming.

## Intelligent Copy

Note: Once you use Intelligent Copy, you cannot use it again until you erase all weekday and weekend time periods by pressing ERASE for 5 seconds.

If your heating and cooling requirements are the same for each day of the week, and for each day of the weekend, your ZSM is designed to employ Intelligent Copy.

To program the five weekdays, Monday through Friday, program only one weekday. Likewise, to program the weekend, Saturday and Sunday, program only one day. After programming one weekday and/or one weekend day, Intelligent Copy automatically copies your program to the other days.

### To use Intelligent Copy:

- 1) Be sure to select the seven day programming format in the Options Menu. See Tables I-P-1 and I-P-2.
- 2) Be sure the entire program is blank.
- 3) Go to Program Menu.
- 4) Enter your setpoint parameters. Intelligent Copy will automatically copy these parameters to the other weekdays.
- 5) Depress the DAY pushbutton until a weekend day icon appears.
- 6) Enter setpoint parameters. Intelligent Copy will automatically copy these parameters to the other weekend day.

### Remote Panel Indicator Signals From UCM to ZSM

The unit control module (UCM) can send four signals to the ZSM.

- Heat
- Cool
- On
- Service

Each of these four signals have three different conditions. See Table I-P-3.

- Off
- On
- Flashing

**Table I-P-2. Zone sensor BAYSENS020 option menu settings**

option	description	value	factory setting
1	morning warmup	0 = disabled 1 = enabled	0
2	economizer minimum position override	0 = disabled 1 = enabled	1
3	temperature scale	0 = Fahrenheit 1 = enabled	0
4	heat installed	0 = no 1 = yes	0
5	time clock	0 = 12 hours 1 = 24 hours	0
6	hydronic heat	0 = no 1 = yes	0
7	daytime warmup	0 = disabled 1 = enabled	0
8	programmable days/week	0 = 7 days (M,T,W,T,F,S,S) 1 = 3 days (M-F, S, S) 2 = 2 days (M-F, S,S)	0
9	programmable periods/day	2,3,4	4
10	remote sensor installed	0 = no 1 = yes	0
11	check filter interval	0 = disabled 3000 to 50 in 50 hour increments	350
12	display zone temperature	0 = no 1 = yes	1
13	keypad lockout enabled	0 = disabled 1 = enabled	1
14	initial time setting in temporary override mode (hrs.)	1,2,3,4,5	3
15	buzzer options	0 = key press only 1 = key press & check filter 2 = key press, check filter, and system failures	1
16	zone temperature calibration	displays current temp. with any offsets	0 offset
17	default cooling setpoint	45 to 98°F (unoccupied)	74°F
18	default heating setpoint	43 to 96°F (unoccupied)	68°F
19	default supply air cool	40 to 80°F (occupied)	55°F
20	default supply air heat	60 to 160°F	100°F
21	default warmup	50 to 90°F (occupied)	68°F
22	minimum cooling setpoint	45 to 98°F	45°F
23	maximum heating setpoint	43 to 96°F	96°F
24	minimum supply air cool	40 to 80°F (occupied)	40°F
25	maximum supply air heat	60 to 160°F	160°F
26	maximum warmup	50 to 90°F	90°F

**Table I-P-3. UCM signal conditions**

	signal	condition
heat	on	Flashing HEAT is ON and indicated by a solid HEAT icon in the Display. Failure in the cooling system indicated by a flashing COOL FAIL icon.
cool	on	Flashing COOLING is ON and indicated by a solid COOL icon in the Display. Failure in the cooling system indicated by a flashing COOL FAIL icon.
on	off on	Flashing System is OFF and indicated by a solid colon on the time of day display. System is ON and indicated by a flashing colon on the time of day display. System is in TEST mode and indicated by a flashing TEST icon.
service	flashing	ON System requires service and is indicated by a solid SERVICE icon. There is a FAN failure indicated by a flashing SERVICE icon.

Note: There is no indication for a signal in the OFF condition. If option 16 is set to "2," any flashing signals will also give audible buzzer indication

# Installation programming

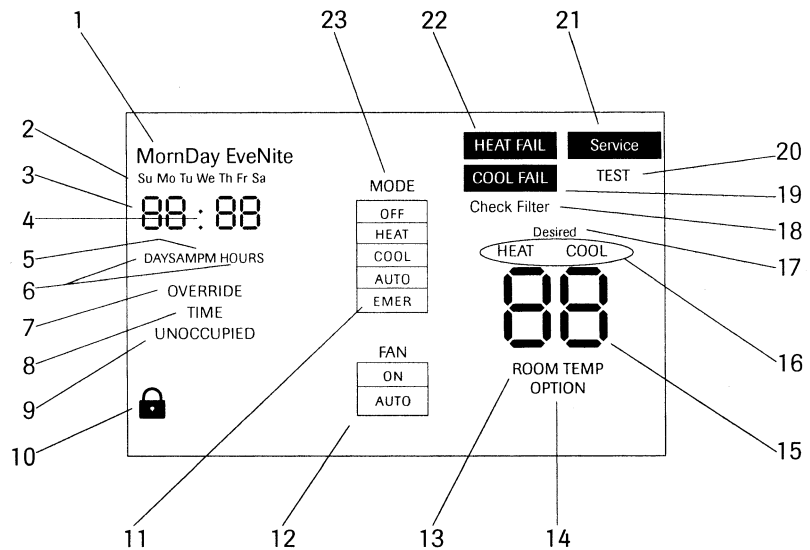

Figure I-P-9. BAYSENS019 complete icon display

## Icon Descriptions

### BAYSENS019 Icon Descriptions

Refer to Figure I-P-9 for the written descriptions below.

1. The four periods of the day used only during programming mode.
2. The seven days of the week used during programming and in normal mode to display the day (not current in Program Menu).
3. Four digits used to display the time of day in normal run mode. Also used in Programming Menu and Temporary manual Override Menu, and options menu.
4. Time of day colon used on the time of day clock. The colon blinks to indicate the UCM system is functional.
5. AM and PM are used to indicate the time of day when using a 12 hour clock. AM and PM are not used when a 24 hour clock is selected.
6. DAYS and HOURS are used to set the override timer period.
7. Displayed in temporary manual OVERRIDE mode, and when setting the override timer.
8. Only used when setting the override timer.
9. Displays the desired state of either OCCUPIED or UNOCCUPIED.
10. The padlock symbol indicates that the keyboard lockout is in effect.
11. This extends the mode selection box in order to accommodate the emergency heat mode on the ZSM heat pump version.
12. Fan mode selection box.
13. Displayed in normal run mode when displaying the actual room temperature.
14. Displayed in option setting mode only.
15. Digits used to display temperature.
16. HEAT and COOL have two functions: they indicate UCM status in normal run mode and indicate which type of setpoint is DESIRED during programming and override setting.
17. Only used during programming and override setting to indicate the DESIRED setpoint temperature.
18. Flashes when check filter timer is elapsed.
19. Flashing cooling fail status indicator.
20. Only used during UCP self-test mode.
21. Flashing service status indicator and fan failure.
22. Flashing heating fail status indicator.
23. Operating MODE selection box.



# Installation programming

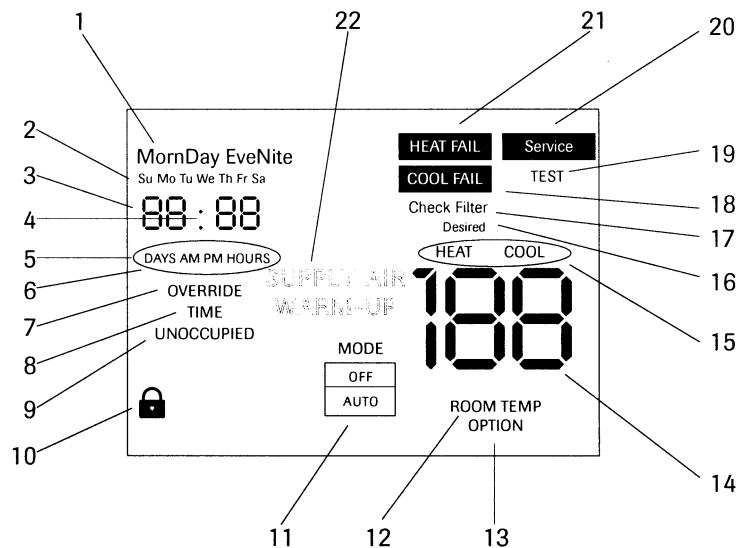

**Figure I-P-10. BAYSENS020 complete icon display**

### BAYSEN020 Icon Descriptions

Refer to Figure I-P-10 for the written descriptions below.

1. The four periods of the day used only during programming mode.
2. The seven days of the week used during programming and in normal run mode.
3. Four digits used to display the time of day in normal run mode. Also used in Programming Mode, override timer setting menu, and options menu.
4. Time of day colon used on the time of day clock. The colon blinks to indicate the UCM system is functional.
5. AM and PM are used to indicate the time of day when using a 12 hour clock. AM and PM are not used when a 24 hour clock is selected.
6. DAYS and HOURS are used to set the override timer period.
7. Displayed in temporary manual OVERRIDE mode, and when setting the override timer.
8. Only used when setting the override timer.
9. Displays the desired state of either OCCUPIED or UNOCCUPIED in the Programming, Run, and Menu.
10. The padlock symbol indicates that the keyboard lockout is in effect.
11. Operating mode selection box.
12. Displayed in normal run mode when displaying the actual room temperature.
13. Displayed in option setting mode only.
14. Digits used to display temperature.
15. HEAT and COOL have two functions: they indicate UCM status in normal run mode and indicate which type of setpoint is DESIRED during programming and override setting.
16. Only used during programming and override setting to indicate the DESIRED setpoint temperature.
17. Flashes when check filter timer is elapsed.
18. Flashing cooling fail status indicator.
19. Only used during UCP self-test mode.
20. Flashing service status indicator and fan failure.
21. Flashing heating fail status indicator.
22. Used in programming mode to set HEAT SUPPLY AIR, COOL SUPPLY AIR, and MORNING WARM-UP temperatures.



# Installation

# programming

## Programming the Time Clock Option

### Setting the Time

Important: Depress the reset key before beginning to set time and program.

1. Select military (24:00 hr.) or AM/PM (12:00 hr.) time mode by depressing and holding the "h" key while pressing "+ 1h" key to toggle between military and AM/PM. (AM appears in the display when in AM/PM mode.)
2. Press and hold down "⊕" key.
3. If setting the time when daylight savings time is in effect, press "+ 1h" key once (+ 1h will appear in display).
4. Set hour with "h" key. If AM or PM does not appear in display, the unit is in military time. See note above to change display.
5. Set minutes with "m" key.
6. Press "Day" key repeatedly to the day of the week. (1 is Monday, 7 is Sunday)
7. Release "⊕" key, colon will begin flashing.

Note: If keys h + or m + are kept depressed for longer than 2 seconds, a rapid advance of figures will result.

The "Digi 20" electronic time switch is freely programmable for each day of the week in one minute increments. For easy and quick programming, the following 4 block programs are available:

- Monday through Sunday
- Monday through Saturday
- Monday through Friday
- Saturday and Sunday

### Programming

Follow the instructions below for programming the time clock.

1. Press "Prog." key. 1234567 AM—:— will appear in display. (Pressing "Prog." key again, display will show the number of free programs "Fr 20"). Press again to RETURN to 1st program.
2. Press "⊕" key, "⊙" ON symbol will appear. Pressing the key again will toggle to OFF "⊖". Select ON or OFF for the program.
3. Press "h+" to select hour for switching time.
4. Press "m+" to select minute for switching time.
5. If the program is to occur every day of the week, (24 hour time control) ignore "Day" key and press "Prog." key to advance to program.
6. For 7 day time control, press "Day" key. 1 2 3 4 5 6 (Monday through Saturday) block of days appears in display. Pressing "Day" key again, 1 2 3 4 5 (Monday through Friday) appears in display. Repeated presses will cycle through all days of the week and back to 1 through 7 (Monday through Sunday). Select day or block of days desired.
7. Press "Prog." key and repeat steps 2 through 6a to enter additional programs of ON and OFF times. (Note that more than one OFF time may be programmed, enabling automatic control or manual overrides.)
8. Press "⊕" key to enter run mode.

### To review and change programs:

1. To review a program at any time, press "Prog." key. Programs display in the sequence they were entered with repeated presses of "Prog." key.
2. To change a program, select that program as outlined in step 1. Enter the time of day and days of week just as in the programming steps above. The old program is overwritten with the new selections. Press "Prog." to store the new program.
3. To delete an individual program, select the program as in step 1 and press "h" and "m" keys until "—:—" appears in the display. Press either "Prog." or "1" key until "—:—" flashes. The program is deleted after a few seconds.

### Manual Override

While in the "run" mode ("⊕" symbol is displayed), pressing the "⊕" key will reverse the load status (switch load off if it is on, or switch it on if it is off). A hand symbol appears in the display to indicate the override is active. At the next scheduled switching time, automatic time control resumes, eliminating the override.

Pressing the "⊕" key a second time "[⊙]" appears in the display indicating the load is permanently on.

Pressing the "⊕" key a third time "[⊖]" appears in the display indicating the load is permanently off.

Pressing the "⊕" key a fourth time returns to automatic, "⊕" appears in the display.

All days shown in the respective blocks will switch on (or off) at the selected hour and minute.

# Installation

# startup

## Unit Startup Procedures

### **⚠️ WARNING**

#### **Hazardous Voltage w/Capacitors!**

Disconnect all electric power, including remote disconnects before servicing. Follow proper lockout/tagout procedures to ensure the power cannot be inadvertently energized. For variable frequency drives or other energy storing components provided by Trane or others, refer to the appropriate manufacturer's literature for allowable waiting periods for discharge of capacitors. Verify with an appropriate voltmeter that all capacitors have discharged. Failure to disconnect power and discharge capacitors before servicing could result in death or serious injury.

**Note:** For additional information regarding the safe discharge of capacitors, see PROD-SVB06A-EN or PROD-SVB06A-FR.

#### **Pre-Startup Checklist**

1. Verify electrical connections are tight.
2. Water-cooled: Access the liquid line service valves. Verify the liquid line service valve is open at startup.

Note: Each compressor suction line contains a low pressure sensor that will shut the compressor down in low pressure situations. See Table O-SO-2.

3. Ensure system components are properly set and installed.
4. Inspect all ductwork and connections.
5. Remove compressor and fan assembly tie down bolts. On 20 - 38 ton units, do not remove the fan assembly shipping blocks. Tie down bolts if the fan speed is 750 rpm or less.
6. Ensure fan rotation is in the direction of the arrow on the fan housing. If it is incorrect, verify the incoming power phasing is correct. Switch wires on the fan contact to properly phase fan if necessary.
7. Check the fan belt condition and tension. Adjust the tension if belts are floppy or squeal continually. Replace worn or

fraying belts in matched sets.

#### **Startup**

### **⚠️ WARNING**

#### **Live Electrical Components!**

During installation, testing, servicing and troubleshooting of this product, it may be necessary to work with live electrical components. Have a qualified licensed electrician or other individual who has been properly trained in handling live electrical components perform these tasks. Failure to follow all electrical safety precautions when exposed to live electrical components could result in death or serious injury.

#### **NOTICE**

#### **Compressor Damage!**

Never manually or automatically pump down system below 7 psig. This will cause the compressor to operate in a vacuum and result in compressor damage.

To start the unit, complete the following steps in order.

1. Apply power to the unit. Close the unit disconnect switch option.
2. Make sure the liquid line service valves are open on water cooled units.
3. Adjust setpoints at the HI.

Note: A sufficient cooling load must be visible to refrigerant circuit controls for mechanical refrigeration to operate. If necessary, temporarily reduce the discharge air setpoint to verify the refrigeration cycle operation.

4. Check voltage at all compressor terminals to ensure it is within 10% of nameplate voltage.
5. Check voltage imbalance from these three voltage readings at each compressor. Maximum allowable voltage imbalance, phase to phase is 2%.
6. Check amp draw at compressor terminals. RLA and LRA is on the unit nameplate.

7. Measure amp draw at evaporator fan motor terminals. FLA data is on the motor nameplate.
8. After the system has stabilized (15 to 30 minutes), check and record operating pressures and temperatures for all circuits.

Using the startup log on the following pages, establish nominal conditions for consistent measurements as follows:

- Leaving air greater than 60°F
- Entering air temperature = 70 to 90°F
- Entering water temperature > 60°F
- Inlet guide vanes at least halfway open

With all compressors running at full load:

1. Compute superheat from the suction line pressure and temperature at the compressor on each circuit. Adjust the thermal expansion valve settings if necessary. Superheat should be between 12 and 17°F.
2. Inspect refrigerant flow in the liquid line sight glass. Flow should be smooth and even, with no bubbles once the system has stabilized.

Normal startup will occur provided that Tracer Summit is not controlling the module outputs or the generic BAS is not keeping the unit off. To prevent Tracer Summit from affecting unit operation, remove Tracer wiring and make required changes to setpoint and sensor sources.

#### **Operating & Programming Instructions**

Reference the *IntelliPak Self-Contained Programming Guide, PKG-SVP01B-EN*, for available unit operating setpoints and instructions. A copy ships with each unit. For units with the VFD option, reference the installer guide that ships with each VFD.





# Installation

# startup

### Water Cooled Units:

Circuit A:  
entering water temperature °F: \_\_\_\_\_ leaving water temperature °F: \_\_\_\_\_  
entering water pressure, psig: \_\_\_\_\_ leaving water pressure, psig: \_\_\_\_\_

Circuit B:  
enter water temperature °F: \_\_\_\_\_ leaving water temperature °F: \_\_\_\_\_  
entering water pressure, psig: \_\_\_\_\_ leaving water pressure, psig: \_\_\_\_\_

Circuit C:  
entering water temperature °F: \_\_\_\_\_ leaving water temperature °F: \_\_\_\_\_  
entering water pressure, psig: \_\_\_\_\_ leaving water pressure, psig: \_\_\_\_\_

Circuit D:  
enter water temperature °F: \_\_\_\_\_ leaving water temperature °F: \_\_\_\_\_  
entering water pressure - psig: \_\_\_\_\_ leaving water pressure, psig: \_\_\_\_\_

Circuit E:  
enter water temperature °F: \_\_\_\_\_ leaving water temperature °F: \_\_\_\_\_  
entering water pressure - psig: \_\_\_\_\_ leaving water pressure, psig: \_\_\_\_\_

Circuit F:  
enter water temperature °F: \_\_\_\_\_ leaving water temperature °F: \_\_\_\_\_  
entering water pressure - psig: \_\_\_\_\_ leaving water pressure, psig: \_\_\_\_\_

### Air Cooled Units:

(data taken from outside condensing unit)

voltage: \_\_\_\_\_ amp draw: \_\_\_\_\_  
          A        B        C                    A        B        C

entering air temperature °F: \_\_\_\_\_ leaving air temperature °F: \_\_\_\_\_

refrigerant pressures at condenser, psig: \_\_\_\_\_ / \_\_\_\_\_ sub cooling at condenser °F: \_\_\_\_\_



# Operation

## general information

### Points List - RTM Module

#### Binary inputs

- Emergency stop
- External auto/stop
- Unoccupied/occupied
- Dirty filter
- VAV changeover with hydronic heat

#### Binary outputs

- VAV box drive max (VAV units only)
- CV unoccupied mode indicator (CV units only)
- Alarm
- Fan run request
- Water pump request (water-cooled only)

#### Analog input

- Airside economizer damper minimum position

#### Analog output

- Outside air damper actuator

#### Heat Module:

- Analog output

### Points List - GBAS Module

#### Binary inputs

- Demand limit contacts

#### Binary outputs

- Dirty filter relay
- Refrigeration fail relay
- Heat fail relay
- Supply fan fail relay
- Active diagnostics

#### Analog inputs

- Occupied zone cooling setpoint
- Occupied zone heating setpoint
- Unoccupied zone cooling setpoint
- Unoccupied zone heating setpoint or minimum outside air flow setpoint
- Supply air cooling setpoint
- Supply air heating setpoint
- Supply air static pressure setpoint

### Points List - ECEM Module

#### Analog inputs

- Return air temperature
- Return air humidity

#### In addition, units with a VOM have:

#### Binary inputs

- VOM mode A, unit off
- VOM mode B, pressurize
- VOM mode C, exhaust
- VOM mode D, purge
- VOM mode E, purge w/duct pressure control

#### Binary outputs

- V.O. relay

### Points List - Tracer™ LCI-I Module

#### Constant Volume (CV) Points

#### Binary inputs

- Airside economizer enable/disable
- Condensor type (air or water cooled)
- Condensor water flow status
- Emergency shutdown
- Local fan switch enable/disable
- Mechanical cooling lockout
- Mechanical heating lockout
- Mixed air temperature
- Occupancy
- Occupancy override
- Occupancy sensor

#### Binary outputs

- Airside economizer status
- Alarm status
- Compressor on/off status
- Condensor circuit information
- Condensor water pump status
- Waterside economizer status

#### Analog inputs

- Airside economizer dry bulb setpoint
- Airside economizer minimum setpoint
- Building static pressure input
- Maintenance required time
- Occupancy bypass time
- Outdoor air damper minimum position setpoint
- Outdoor air relative humidity
- Outdoor air temperature
- Unit start delay time setpoint
- Zone temperature
- Zone temperature setpoint
- Zone temperature setpoint (default)
- Zone temperature setpoint limits
- Zone temperature setpoint offsets
- Zone temperature setpoint shift

#### Analog outputs

- Alarm message
- Building static pressure status
- Condensor saturated refrigerant temp
- Condensor water temperature
- Cooling output status
- Effective occupancy
- Exhaust fan status
- Heating output status
- Heating/cooling mode
- Morning warm up sensor temperature
- Outdoor air damper position
- Outdoor air enthalpy
- Outdoor air relative humidity
- Return air temperature

- Supply air temperature
- Supply fan status
- Unit status mode
- Zone CO2
- Zone relative humidity

#### Variable Air Volume (VAV) Points

#### Binary inputs

- Airside economizer enable/disable
- Condensor water flow input
- Emergency override
- Local fan switch enable/disable
- Mechanical cooling lockout
- Mechanical heating lockout
- Occupancy

#### Binary outputs

- Airside economizer status
- Alarm status
- Compressor on/off status
- Condensor circuit information
- Condensor type (water or air cooled)
- Condensor waterflow status
- Condensor water pump status

#### Analog inputs

- Airside economizer dry bulb setpoint
- Airside economizer minimum position
- Building static pressure input
- Building static pressure setpoint
- Daytime warm up setpoint
- Daytime warm up terminate setpoint
- Maintenance required time
- Occupancy bypass time
- Outdoor air damp min position setpoint
- Outdoor airflow minimum setpoint
- Outdoor air relative humidity
- Outdoor air temperature
- Supply air cooling setpoint
- Supply air cooling setpoint (default)

#### Analog outputs

- Building static pressure status
- Alarm message
- Condensor saturated refrigerant temp.
- Condensor water temperature
- Condensor water temp (local)
- Cooling output status
- Exhaust fan status
- Heating output status
- Heating/cooling mode
- Mixed air temperature
- Morning warm up sensor temperature
- Outdoor air damper position
- Outdoor air enthalpy
- Outdoor air flow
- Outdoor air relative humidity status
- Outdoor air temperature status
- Return air temperature

## Operation

### Unit Control Components

The Modular Series IntelliPak self-contained unit is controlled by a microelectronic control system that consists of a network of modules. These modules are referred to as unit control modules (UCM). In this manual, the acronym UCM refers to the entire control system network.

These modules perform specific unit functions using proportional/integral control algorithms. They are mounted in the unit control panel and are factory wired to their respective internal components. Each module receives and interprets information from other unit modules, sensors, remote panels, and customer binary contacts to satisfy the applicable request; i.e., economizing, mechanical cooling, heating, ventilation. Following is a detailed description of each module's function.

### RTM Module Board - Standard on all Units

The RTM responds to cooling, heating, and ventilation requests by energizing the proper unit components based on information received from other unit modules, sensors, remote panels, and customer supplied binary inputs. It initiates supply fan, exhaust fan, exhaust damper, inlet guide vane positioning or variable frequency drive output, and airside economizer operation based on that information.

Reference the RTM points list.

Note: Emergency stop and external auto-stop, stop the unit immediately, emergency stop generates a manual reset diagnostic that must be reset at the unit human interface. External auto-stop will return the unit to the current operating mode when the input is closed, so this input is auto reset.

### RTM Remote Economizer Minimum Position

The remote minimum position potentiometer, BAYSTAT023A, provides a variable resistance (0-270 ohms) to adjust the economizer minimum position from 0 to 100% when connected to the economizer remote minimum position

input of the RTM. The RTM must be selected as the source for economizer minimum position. If the RTM is the selected source for economizer minimum position, and *if a valid resistance per Table O-GI-1 is provided to the RTM remote minimum position input*, the OA cfm compensation function will not operate, even if enabled. "Default" is the only possible source for economizer minimum position when using the OA cfm compensation function.

**Table O-GI-1. Economizer remote minimum position input resistance**

input resistance	economizer min. position
0 - 30 ohms	0 %
30 - 240 ohms	0-100 % (linear)
240 - 350 ohms	100 %
≥ 350 ohms	N/A *

\* Note: A resistance greater than 350 ohms is assumed to be an open circuit. The system will use the default minimum position value.

### RTM Analog Outputs

The RTM has two 0-10 vdc outputs: one for the inlet guide vane option and one for the economizer option. These outputs provide a signal for one or two damper actuators. There are no terminal strip locations associated with these wires. They go directly from pins on the RTM circuit board to the actuator motor.

### RTM Binary Outputs

The RTM has an output with pressure switch proving inputs for the supply fan. There is a 40 second delay from when the RTM starts the supply fan until the fan proving input must close. A fan failure diagnostic will occur after 40 seconds. This is a manual reset diagnostic, and all heating, cooling, and economizer functions will shut down. If this proving input is jumped, other nuisance diagnostics will occur. If the proving input fails to close in 40 seconds, the economizer cycles to the minimum position. This is a manual reset diagnostic. External control of the fan is not recommended.

### VAV Drive Max Output

This is a single-pole, double-throw relay rated at a maximum voltage of 24 vac, two amps. The relay contacts of this relay switch when the unit goes from the occupied mode to the unoccupied mode by means of the occupied binary input. The contacts will stay switched during the

unoccupied and morning warmup mode. They will return to the position shown on the unit wiring diagram when the unit returns to the occupied mode. This binary output signals the VAV boxes or other terminal devices to go full open.

### RTM Alarm Relay

This is a single pole, double throw relay rated at a maximum voltage of 24 vac, two amps max. Relay contacts can be programmed from the unit human interface. This relay can be programmed to pick up on any one or group of diagnostics from the unit human interface.

### Status/Annunciator Output

The status annunciator output is an internal function within the RTM module on CV and VAV units. It provides:

- diagnostic and mode status signals to the remote panel (LEDs) and to the Human Interface.
- control of the binary alarm output on the RTM.
- control of the binary outputs on the GBAS module to inform the customer of the operational status and/or diagnostic conditions.

### Occupied/Unoccupied Inputs

There are four ways to switch to occupied/unoccupied:

- Field-supplied contact closure hardwired binary input to the RTM
- Programmable night setback zone sensor
- Tracer Summit
- Factory-mounted time clock

### VAV Changeover Contacts

These contacts are connected to the RTM when daytime heating on VAV units with internal or external hydronic heat is required. Daytime (occupied) heating switches the system to a CV unit operation. Refer to the unit wiring diagram for the field connection terminals in the unit control panel. The switch must be rated at 12 ma @ 24 VDC minimum.

### External Auto/Stop Switch

A field-supplied switch may be used to shut down unit operation. This switch is a binary input wired to the RTM. When opened, the unit shuts down immediately and can be cancelled by closing the switch. Refer to the unit wiring diagrams (attached to the unit control panel) for proper connection terminals. The switch



# Operation

# general information

must be rated for 12 ma @ 24VDC minimum. This input will override all VOM inputs, if the VOM option is on the unit.

### Occupied/Unoccupied Contacts

To provide night setback control if a remote panel *with night setback* was not ordered, install a field-supplied contact. This binary input provides the building's occupied/unoccupied status to the RTM. It can be initiated by a time clock, or a building automation system control output. The relay's contacts must be rated for 12 ma @ 24 VDC minimum. Refer to the appropriate wiring diagrams (attached to the unit control panel for the proper connection terminals in the unit control panel.

### Emergency Stop Input

A binary input is provided on the RTM board for installation of a field-supplied normally closed (N.C.) switch to use during emergency situations to shut down all unit operations. When open, an immediate shutdown occurs. An emergency stop diagnostic enters the human interface and the unit will require a manual reset. Refer to the unit wiring diagrams (attached to the unit control panel for the proper connection terminals. The switch must be rated for 12 ma @ 24 VDC minimum. This input will override all VOM inputs, if the VOM option is on the unit.

### VAV Box Option

To interlock VAV box operation with evaporator fan and heat/cool modes, wire the VAV boxes/air valves to VAV box control connections on the terminal block.

### Supply Duct Static Pressure Control

The RTM relies on input from the duct pressure transducer when a unit is equipped with IGV or VFD to position the IGV or set the supply fan speed to maintain the supply duct static pressure to within the static pressure setpoint deadband.

### RTM Sensors

RTM sensors include: zone sensors with or without setpoint inputs and modes, supply air sensor, duct static pressure, outside air temperature, outside air humidity, airflow proving, and dirty filter.

**Table O-GI-2. RTM sensor resistance vs. temperature**

temperature, °F	resistance, Ω ohms	temperature, °F	resistance, Ω ohms
-40	346.1	71	11.60
-30	241.7	72	11.31
-20	170.1	73	11.03
-10	121.4	74	10.76
-5	103.0	75	10.50
0	87.56	76	10.25
5	74.65	77	10.00
10	63.8	78	9.76
15	54.66	79	6.53
20	46.94	80	9.30
25	40.40	85	8.25
30	34.85	90	7.33
35	30.18	100	5.82
40	26.22	105	5.21
45	22.85	110	4.66
50	19.96	120	3.76
55	17.47	130	3.05
60	15.33	140	2.50
65	13.49	150	2.05
66	13.15	160	1.69
67	12.82	170	1.40
68	12.50	180	1.17
69	12.19	190	0.985
70	11.89	200	0.830

**Table O-GI-3. RTM setpoint analog inputs**

cooling or heating setpoint input, °F (using RTM as zone temp. source) ohms	cooling setpoint input, °F (using RTM as supply air temp. source)	resistance, Ω
40	40	1084
45	45	992
50	50	899
55	55	796
60	60	695
65	65	597
70	70	500
75	75	403
80	80	305
NA	85	208
NA	90	111

**Table O-GI-4. RTM resistance value vs. system operating mode**

resistance applied to RTM mode input terminals, ohms	CV units		VAV units system mode
	fan mode	system mode	
2320	auto	off	off
4870	auto	cool	
7680	auto	auto	auto
10,770	on	off	
13,320	on	cool	
16,130	on	auto	
19,480	auto	heat	
27,930	on	heat	

Note: Mode boundaries are 1000 to 40,000 ohms. Other boundaries are equal to the midpoint between the nominal mode resistance.



## Operation

### Compressor Module (MCM - Standard on all Units)

The compressor module, (single circuit and multiple circuit) energizes the appropriate compressors and condenser fans upon receiving a request for mechanical cooling. It monitors the compressor operation through feedback information it receives from various protection devices.

### Human Interface Module - Standard on all Units

The human interface (HI) module enables the operator to adjust the operating parameters for the unit using its 16-key keypad on the human interface panel. The HI panel provides a two line, 40 character, clear language (English, Spanish, or French) LCD screen with unit status information and menus to set or modify operating parameters. It is mounted in the unit's main control panel and accessible through the unit's control panel door.

### Remote Human Interface Module Option

The optional remote-mount human interface (RHI) panel has all the functions of the unit-mounted version except for service mode. To use a RHI, the unit must be equipped with an optional interprocessor communications bridge (IPCB). Model number digit 32 (=2) indicates if the IPCB was ordered with the unit. If not, contact your local Trane representative to order an IPCB kit for field installation. The RHI can be located up to 1,000 feet (304.8 m) from the unit. A single RHI can monitor and control up to four self-contained units if each one contains an IPCB. The IPCB switches must be set as SW1- off, SW2 - off, and SW3 - on.

### Interprocessor Communications Board • Option used with RHI

The interprocessor communication board expands communications from the unit's UCM network to a remote human interface panel. DIP switch settings on the IPCB module for this application are; switches 1 and 2 "off," switch 3 "on."

### Waterside Module - Standard on all water-cooled units

The waterside module (WSM) controls all water valves based on unit configuration. In addition, the WSM monitors waterflow proving and the following temperatures:

- entering water
- entering air low
- mixed air
- entering condenser water
- refrigerant circuit 3:
  - saturated condenser
  - evaporator frost
  - motor winding
- refrigerant circuit 4:
  - condenser
  - evaporator
  - motor winding

### Cooling Tower Interlock

To interlock condenser pump/tower with cooling operation, wire the cooling tower to an external 115 volt control power source, to ground, and to control terminal block. Normally open/closed contacts are provided.

### Heat Module

The heat module is standard on all units with factory-installed heat. It controls the unit heater to stage up and down to bring the temperature in the controlled space to within the applicable heating setpoint. Also, it includes a freeze stat, morning warmup, and heating outputs.

### Ventilation Override Module (VOM) Option

The ventilation override module can be field-configured with up to five different override sequences for ventilation override control purpose. When any one of the module's five binary inputs are activated, it will initiate specified functions such as; space pressurization, exhaust, purge, purge with duct pressure control, and unit off.

Once the ventilation sequences are configured, they can be changed unless they are locked using the HI. Once locked, the ventilation sequences cannot be unlocked.

The compressors and condenser fans disable during the ventilation operation. If more than one ventilation sequence

activates, the one with the highest priority (VOM "A") begins first, with VOM "E" having lowest priority and beginning last.

A description of the VOM binary inputs follows below.

### UNIT OFF sequence "A"

When complete system shut down is required, the following sequence can be used.

- Supply fan – off
- Supply fan VFD – off (0 Hz)
- Inlet guide vanes – closed
- Outside air dampers – closed
- Heat – all stages – off, modulating heat output at 0 vdc
- Occupied/Unoccupied output – de-energized
- VO relay – energized
- Exhaust fan (field-installed) - off
- Exhaust damper (field-installed) - closed

### PRESSURIZE sequence "B"

This override sequence can be used if a positively pressurized space is desired instead of a negatively pressurized space.

- Supply fan – on
- Supply fan VFD – on (60 Hz)
- Inlet guide vanes/VAV boxes – open
- Outside air dampers – open
- Heat – all stages – off, hydronic heat output at 0 vdc
- Occupied/ unoccupied output - energized
- VO relay - energized
- Exhaust fan (field-installed) - off
- Exhaust damper (field-installed) - closed

### EXHAUST sequence "C"

With the building's exhaust fans running and the unit's supply fan off, the conditioned space becomes negatively pressurized. This is desirable for clearing the area of smoke when necessary; i.e. from an extinguished fire, to keep smoke out of areas that were not damaged.

- Supply fan – off
- Supply fan VFD – off (0 Hz)
- Inlet guide vanes – closed
- Outside air dampers – closed
- Heat – all stages – off, hydronic heat output at 0 vdc
- Occupied/Unoccupied output – de-energized
- VO relay – energized
- Exhaust fan (field-installed) - on
- Exhaust damper (field-installed) - open

## Operation

### PURGE sequence "D"

This sequence can purge the air out of a building before coming out of unoccupied mode of operation in a VAV system. Also, it can be used to purge smoke or stale air.

- Supply fan – on
- Supply fan VFD – on (60 hz)
- Inlet guide vanes/VAV boxes – open
- Outside air damper – open
- Heat – all stages – off, modulating heat output at 0 vdc
- Occupied/Unoccupied output – energized
- VO relay – energized
- Exhaust fan (field-installed) - on
- Exhaust damper (field-installed) - open

### PURGE with duct pressure control "E"

This sequence can be used when supply air control is required for smoke control.

- Supply fan – on
- Supply fan VFD – on (if equipped)
- Inlet guide vanes – controlled by supply air pressure control function with supply air pressure high limit disabled
- Outside air dampers – open
- Heat – all stages – off, hydronic heat output at 0 vdc
- Occupied/unoccupied output – energized
- VO relay – energized
- Exhaust fan (field-installed) - on
- Exhaust damper (field-installed) - open

Note: Each system (cooling, exhaust, supply air, etc.) within the unit can be redefined in the field for each of the five sequences, if required. Also the definitions of any or all of the five sequences may be locked into the software by simple key strokes at the human interface panel. Once locked into the software, the sequences cannot be changed.

### Trane IntelliPak Lon-Talk Communication Module (LCI-Option used on units with Trane ICS™ or 3rd party Building Automation Systems)

The LonTalk Communication Interface module expands communications from the unit UCM network to a Trane Tracer Summit™ or a 3rd party building automation system, utilizing LonTalk, and allows external setpoint and configuration adjustment and monitoring of status and diagnostics.

### Exhaust/Comparative Enthalpy (ECEM) Module - Option used on units with comparative enthalpy option

The exhaust/comparative enthalpy module receives information from the return air humidity sensor, and the RTM outside air temperature sensor and outside air humidity sensor, the outside air humidity sensor and temperature sensor to utilize the lowest possible enthalpy level when considering economizer operation. In addition, it receives space pressure information to maintain the space pressure within the

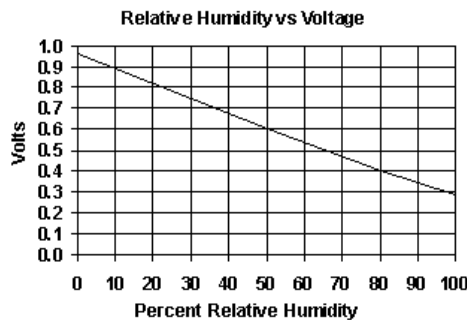

Figure O-GI-1. ECEM relative humidity vs. voltage

### Ventilation Control Module (VCM) - Available only with Traq™ Damper Option

The ventilation control module (VCM) is located in the airside economizer section of the unit and linked to the unit's UCM network. Using a velocity pressure transducer/solenoid (pressure sensing ring) in the fresh air section allows the VCM to monitor and control fresh air entering the unit to a minimum airflow setpoint. See Figure O-GI-2 for a detail view of the velocity pressure transducer/solenoid assembly.

An optional temperature sensor can be connected to the VCM to enable control of a field installed fresh air preheater.

Also, a field-provided CO<sub>2</sub> sensor can be connected to the VCM to control CO<sub>2</sub> reset. The reset function adjusts the minimum cfm upward as the CO<sub>2</sub> concentrations increase. The maximum effective (reset) setpoint value for fresh air entering the unit is limited to the system's operating cfm. Table O-GI-5 lists the minimum outside air cfm vs. input voltage.

Table O-GI-5. Minimum outside air setpoint w/VCM module and Traq™ sensing

Unit	Input Volts	CFM
SXWG 20	0.5 - 4.5 vdc	6,350-8,500
SXWG 25	0.5 - 4.5 vdc	7,250-10,625
SXWG 30	0.5 - 4.5 vdc	7,250-12,750
SXWG 35	0.5 - 4.5 vdc	7,250-14,875
SXRG 20	0.5 - 4.5 vdc	7,250-8,500
SXRG 25	0.5 - 4.5 vdc	7,250-10,625
SXRG 32	0.5 - 4.5 vdc	7,250-13,600

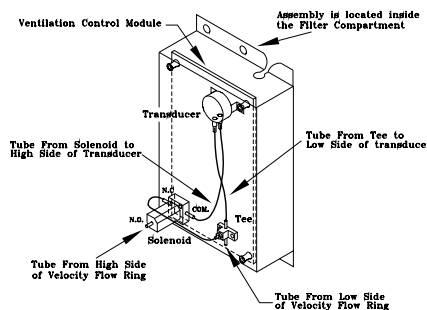

Figure O-GI-2. Velocity pressure transducer/solenoid assembly

## Operation

### Generic Building Automation System Module Option

The generic building automation system module (GBAS) provides broad control capabilities for building automation systems other than Trane's Tracer system. A field provided potentiometer or a 0-5 vdc signal can be applied to any of the inputs of the GBAS to provide the following points:

#### GBAS Analog Inputs

Four analog inputs that can be configured to be any of the following:

- (1) occupied zone cooling
- (2) unoccupied zone cooling
- (3) occupied zone heating
- (4) unoccupied zone heating
- (5) SA cooling setpoint
- (6) SA heating setpoint
- (7) space static pressure setpoint
- (8) SA static pressure setpoint

#### GBAS Binary Outputs

Five binary outputs to provide diagnostics, signaling up to five alarms. Each of the five (5) relay outputs can be mapped to any/all of the available diagnostics. Each output contains a dry N.O. and N.C. contact with a VA rating of 2 amps at 24 VAC.

#### GBAS Binary Input

One binary input for the self-contained unit to utilize the demand limit function. This function is operational on units with a GBAS and is used to reduce electrical consumption at peak load times. Demand limiting can be set at either 50% or 100%. When demand limiting is needed, mechanical cooling and heating (with field-provided 2-stage electric heat only) operation are either partially (50%), or completely disabled (100%) to save energy. The demand limit definition is user definable at the HI panel. Demand limit binary input accepts a field supplied switch or contact closure. When the need for demand limiting has been discontinued, the unit's cooling/heating functions will again become fully enabled.

#### GBAS Communication (Analog Inputs)

The GBAS accepts external setpoints in the form of analog inputs for cooling, heating, supply air pressure. Refer to the unit wiring diagram for GBAS input wiring and the various desired setpoints with the corresponding DC voltage inputs.

Any of the setpoint or output control parameters can be assigned to each of the four analog inputs on the GBAS module. Also, any combination of the setpoint and/or output control parameters can be assigned to the analog inputs through the HI. To assign the setpoints apply an external 0-5 vdc signal:

1. directly to the signal input terminals, or
2. to the 5 vdc source at the GBAS module with a 3-wire potentiometer.

Note: There is a regulated 5 vdc output on the GBAS module that can be used with a potentiometer as a voltage divider. The recommended potentiometer value is 1000-100,000 ohms.

The setpoints are linear between the values shown in Table O-GI-6 on page 66. Reference Table O-GI-7 on page 66 for corresponding input voltage setpoints. Following are formulas to calculate input voltage or setpoint. SP = setpoint, IPV = input voltage.

#### If the setpoint range is 50-90°F:

$$IPV = (SP - 50)(0.1) + 0.5$$

$$SP = [(IPV - 0.5)/0.1] + 50$$

#### If the setpoint range is 40-90°F:

$$IPV = (SP - 40)(0.8) + 0.5$$

$$SP = [(IPV - 0.5)/0.08] + 40$$

#### If the setpoint range is 40-180°F:

$$IPV = (SP - 40)(0.029) + 0.5$$

$$SP = [(IPV - 0.5)/0.029] + 40$$

#### If the static pressure range is 0.03-0.3 iwc:

$$IPV = (SP - 0.03)(14.8) + 0.5$$

$$SP = [(IPV - 0.5)/14.8] + 0.03$$

#### If the static pressure range is 0.0-5.0 iwc:

$$IPV = (SP)(0.8) + 0.5$$

$$SP = [IPV/(0.8 + 0.5)]$$

#### GBAS Demand Limit Relay (Binary Input)

The GBAS allows the unit to utilize the demand limit function by using a normally open (N.O.) switch to limit the electrical power usage during peak periods. Demand limit can initiate by a toggle switch closure, a time clock, or an ICS control output. These contacts must be rated for 12 ma @ 24 VDC minimum.

When the GBAS module receives a binary input signal indicating demand limiting is required, a command initiates to either partially (50%) or fully (100%)

inhibit compressor and heater operation. This can be set at the HI using the setup menu, under the "demand limit definition cooling" and "demand limit definition heating" screens. A toggle switch, time clock, or building automation system control output can initiate demand limiting.

If the cooling demand limit is set to 50%, half of the cooling capacity will disable when the demand limit binary input closes. The heating demand limit definition can only be set at 100%, unless the unit has field-provided two-stage electric heat. In that case, if the heating demand limit is set to 50%, half or one stage of heating disables when the demand limit binary input closes. If the demand limit definition is set to 100%, then all cooling and/or heating will disable when the demand limit input closes.

#### GBAS Diagnostics (Binary Outputs)

The GBAS can signal up to five alarm diagnostics, which are fully mappable through the setup menu on the HI. These diagnostics, along with the alarm output on the RTM, allow up to six fully mappable alarm outputs.

Each binary output has a NO and NC contact with a rating of two amps at 24 VAC. The five binary outputs are factory preset as shown on the unit wiring diagram (on the unit control panel door). However, these outputs can be field defined in a variety of configurations, assigning single or multiple diagnostics to any output.

For a complete listing of possible diagnostics, see the *IntelliPak Self-Contained Programming Guide, PKG-SVP01B-EN*. For terminal strip locations, refer to the unit wiring diagram for the GBAS.



# Operation

# general information

**Table O-GI-6. GBAS analog input setpoints**

control parameter	signal range	setpoint range
occupied zone cooling setpoint (CV units only)	0.5 to 4.5 vdc	50 to 90°F
unoccupied zone cooling setpoint (CV and VAV)	0.5 to 4.5 vdc	50 to 90°F
occupied zone heating setpoint (CV units only)	0.5 to 4.5 vdc	50 to 90°F
unoccupied zone heating setpoint (CV and VAV)	0.5 to 4.5 vdc	50 to 90°F
supply air cooling setpoint (VAV units only)	0.5 to 4.5 vdc	40 to 90°F
supply air hydronic heating setpoint (VAV units only)	0.5 to 4.5 vdc	40 to 180 F
space static pressure setpoint	0.5 to 4.5 vdc	0.03 to 0.30 IWC
supply air pressure setpoint (VAV units only)	0.5 to 4.5 vdc	0.0 to 5.0 IWC

Notes: 1. Input voltages less than 0.5 vdc are considered as 0.5 vdc input signal is lost, the setpoint will “clamp” to the low end of the setpoint scale. No diagnostic will result from this condition.  
 2. Input voltages greater than 4.5 vdc are considered to be 4.5 vdc.  
 3. The actual measured voltage is displayed at the HI.

**Table O-GI-7. GBAS input voltage corresponding setpoints**

volts	temp. °F	volts	temp. °F	volts	temp. °F	volts	temp. °F
0.5	50	1.6	60	2.6	70	2.7	80
0.6	51	1.7	61	2.7	71	2.8	81
0.7	52	1.8	62	2.8	72	2.9	82
0.8	53	1.9	63	2.9	73	3.0	83
0.9	54	2.0	64	3.0	74	3.1	84
1.0	55	2.1	65	3.1	75	3.2	85
1.1	56	2.2	66	3.2	76	3.3	86
1.2	57	2.3	67	3.3	77	3.4	87
1.3	58	2.4	68	3.4	78	3.5	88
1.5	59	2.5	69	3.5	79	3.6	89

## Operation

### Waterside Components

Waterside components consist of water piping, water valves, water flow switch option, water cooled condensers (SXWF only), and the economizer option.

#### Water Purge

This user-definable feature allows the user to select a purge schedule to automatically circulate water through the economizer and condensers periodically during non-operational times. This allows fresh chemicals to circulate in waterside heat exchangers. This feature is on all units and is defined at the HI.

#### Water Piping Options

Water piping is factory-installed with left-hand connections on units without a waterside economizer. Units can be ordered with either basic piping or intermediate piping. Also, units with waterside economizers can be set for either variable or constant water flow at the HI. See Figures O-GI-3, O-GI-4, and O-GI-5 for detailed piping configuration information.

With compatible piping configurations, the unit can be configured to provide:

1. Constant water flow with basic or intermediate piping or
2. Variable water flow (head pressure control) with intermediate piping only.

Constant water flow is for condenser pumping systems that are not capable of unloading the water-pumping system.

Variable water flow maximizes energy saving by unloading the water pumping system.

#### Basic Water Piping

This option is available on units without a waterside economizer and with condenser water applications above 54°F (12.2°C) that do not require condensing pressure control. Left hand water connections and piping are extended to the unit exterior. Manifold piping is factory installed.

#### Intermediate Water Piping

This option provides condensing temperature control when the unit is configured (user defined at the HI) for variable water flow with or without a waterside economizer. A two-way modulating control valve is wired and installed in the unit to maintain a specific

range of water temperature rise through the condenser when entering fluid temperature is less than 58°F (15°C). This option allows the compressor to operate with entering fluid temperature down to 35°F (2°C). The minimum valve position to maintain minimum condenser flow rates is user-defined at the HI. This valve drives closed if the unit shuts down or if a power failure occurs.

#### Water Flow Switch Option

A water flow switch is factory installed in the condenser water pipe within the unit. Whenever the flow switch detects a water flow loss prior to or during mechanical cooling, compressor operation locks out and a diagnostic code displays. If water flow is restored, the compressor operation automatically restores.

#### Water-Cooled Condensers

Units that are set up for variable water flow will modulate a water valve to maintain a user-defined condensing temperature setpoint. Condensing temperature will be referenced utilizing factory installed sensors located at each condenser.

**Table O-GI-8. Condenser water piping connection sizes**

unit size	inlet pipe	outlet pipe
SXWG 20, 25, 30, 32, 35	2 1/2 NPT	2 1/2 NPT

#### Waterside Economizer Option

The waterside economizer option takes advantage of cooling tower water to either precool the entering air to aid the mechanical cooling process or, if the water temperature is low enough, provide total system cooling. Waterside economizing enables when the unit's entering water temperature is below the unit's entering mixed air temperature by a minimum of 4°F plus the economizer's approach temperature. The approach temperature default is 4°F. Waterside economizing disables when the unit's entering water temperature is not below the unit's entering mixed air temperature by at least the water economizer approach temperature. The approach temperature defaults to 4°F. The economizer acts as the first stage of

cooling. If the economizer is unable to maintain the supply air setpoint, the unit control module brings on compressors as required to meet the setpoint.

The waterside economizer includes a coil, modulating valves, controls, and piping with cleanouts. The coil construction is 1/2-inch (13 mm) OD seamless copper tubes expanded into aluminum fins. The evaporator and economizer coils share a common sloped (IAQ) drain pan. Drain pan options are either galvanized or stainless steel, and are insulated and internally trapped.

The waterside economizer coil is available with either a two or four row coil, with no more than 12 fins per inch. The tubes are arranged in a staggered pattern to maximize heat transfer. The coil has round copper supply and return headers with removable cleanout and vent plugs. The optional mechanical cleanable economizer has removable cast iron headers to allow easy mechanical cleaning of the tubes. The waterside working pressure is rated for 400 psig (2758 kPa).

#### Waterside Economizer Flow Control

Units equipped with a waterside economizer can be set from the human interface panel for variable or constant water flow.

#### Constant Water Flow

Two-way modulating control shutoff valves are wired, controlled, and installed in the unit. One valve is located in the economizer's water inlet, and the other is in the condenser bypass water inlet. When the waterside economizer enables, the two-way valves modulate to maintain the discharge air temperature setpoint. As the economizer valve opens, the condenser bypass valve closes, and vice versa. Full water flow is always maintained through the condensers. Both valves will close in the event of a power failure.

#### Variable Water Flow

Two-way modulating control shutoff valves are wired, controlled, and installed in the unit. One valve is located in the economizer's water inlet, and the other is in the condenser water inlet. When the economizer valve is active, the condenser bypass valve closes. The

# Operation

# general information

economizer valve modulates, thus water flow through the unit modulates. If the water is cool enough for economizing, but mechanical cooling is also required, the economizer valve fully opens to establish full water flow through the condensers. Whenever the water is too warm for economizing and there is a call for cooling, the economizer valve fully closes and the bypass valve fully opens, establishing full water flow through the condensers. Full water flow is always maintained through the condensers when mechanical cooling is required. Both valves close whenever cooling is not required, and in the event of a power failure.

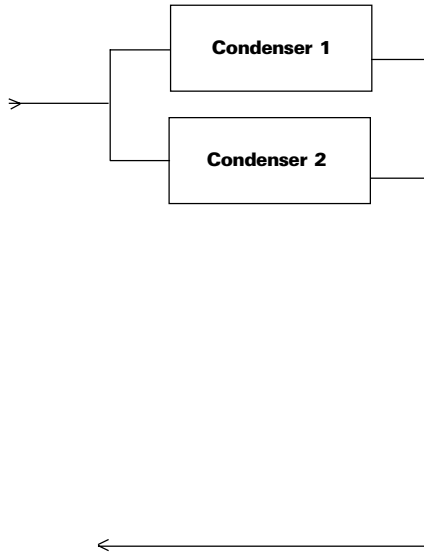

*Figure O-GI-3. Basic water piping, constant water flow*

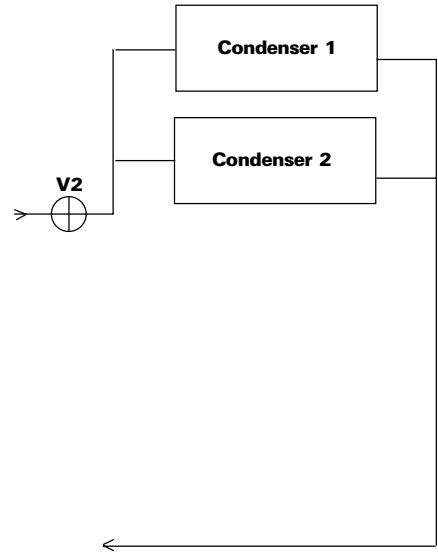

*Figure O-GI-4. Intermediate water piping, variable water flow*

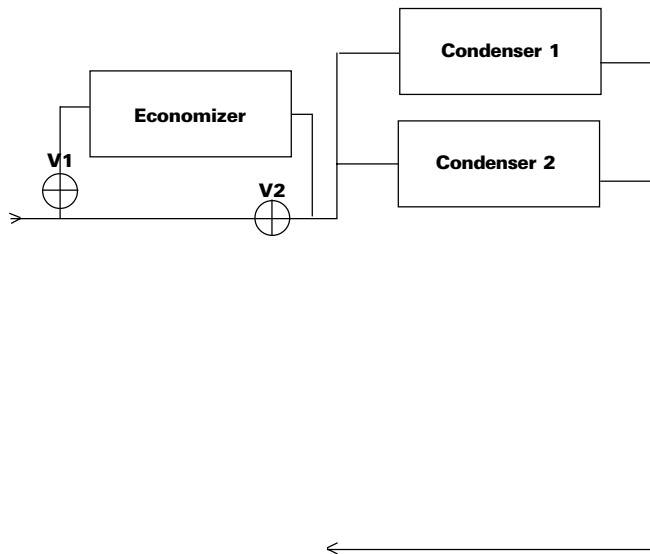

*Figure O-GI-5. Intermediate piping with waterside economizer, variable or constant water flow*

## Operation

### Unit Airside Components

The unit's air delivery system consists of dampers, enthalpy switch option, airside economizer option, filters, low ambient sensors, and factory mounted single or double wall plenums.

#### Supply Air Fan

The unit has a single supply fan that runs at a constant speed. However, the fan may have the IGV or VFD option that modulates airflow based on supply air temperature control. Pressing the stop key on the HI will turn the supply fan off. The fan is on continuously when a CV unit is in occupied mode and except when a unit is in the night heat/morning warmup mode. During the night heat and setback mode the fan cycles on and off in response to a call for heat. See Table O-GI-9 for available fan horsepower.

#### Low Entering Air Temperature Sensor

This is standard on all units with a hydronic coil or waterside economizer. It can also be ordered as an option.

A thermostat limit switch is factory mounted on the unit's entering air side with a capillary tube serpentine across the coil face. If the temperature falls below 35°F (2°C), the fan shuts down and the waterside economizer and/or hydronic heat valve options open to allow full water flow. The heat output also energizes. A manual reset is required. The low entering air temperature setpoint is adjustable at the HI.

#### High Duct Temperature Thermostat

A factory-supplied temperature limit switch with reset element detects the supply air duct temperature. This sensor should be field-installed downstream from the unit's discharge in the supply air duct. If the supply air duct temperature exceeds 240°F (115.6°C), the unit shuts down and displays a diagnostic. A manual reset is required at the unit. The high duct temperature can be adjusted at the thermostat.

#### Dirty Filter Sensor Option

A factory installed pressure switch senses the pressure differential across the filters. When the differential pressure exceeds 0.9-inches (23 mm) WG, contact closure occurs and the HI will display a diagnostic. The unit will continue to run until you replace the air filters.

A field installed indicator device may be wired to relay terminals to indicate when filter service is required. Contacts are rated at 115 VAC and are powered by a field supplied transformer.

#### Low Ambient Sensor (Air-Cooled Units)

The low ambient sensor is field-installed on air-cooled units. Position it in a location subject to ambient temperatures only and not exposed to direct sunlight or exhaust fans.

The low pressure cutout initiates based on the ambient temperature. A time delay on the low pressure cutout initiates for ambient temperatures between 50 (zero minutes) and 0°F (10 minutes). This helps to prevent nuisance low pressure cutout trips.

#### Inlet Guide Vane Option

Inlet guide vanes (IGV's) are driven by a modulating 0-10 vdc signal from the RTM module. A pressure transducer measures duct static pressure, and the IGVs modulate to maintain the supply air static pressure within an adjustable user-defined range. The range is determined by the supply air pressure setpoint and supply air pressure deadband, which are set through the HI panel.

IGV assemblies installed on the supply fan inlet regulate fan capacity and limit horsepower at lower system air requirements. When in any position other than full open, the vanes pre-spin the air in the same direction as the supply fan rotation. As the vanes approach the full-closed position, the amount of "spin" induced by the vanes increases at the same time that intake airflow and fan horsepower diminish. The IGVs will close when the supply fan is off.

#### Supply Air Static Pressure Limit

The opening of the IGVs and VAV boxes coordinate during unit startup and transition to/from occupied/unoccupied

modes to prevent supply air duct overpressurization. However, if for any reason the supply air pressure exceeds the user-defined supply air static pressure limit set at the HI panel, the supply fan/VFD shuts down and the IGVs close. The unit will attempt to restart, up to three times. If the overpressurization condition still occurs on the third restart, the unit shuts down and a manual reset diagnostic sets and displays at the HI.

#### Variable Frequency Drive Option

The variable frequency drive (VFD) is driven by a modulating 0-10 vdc signal from the RTM module. A pressure transducer measures duct static pressure, and the VFD adjusts the fan speed to maintain the supply air static pressure within an adjustable user-defined range. The range is determined by the supply air pressure setpoint and supply air pressure deadband, which are set at the HI panel.

VFDs provide supply fan motor speed modulation. The drives will accelerate or decelerate as required to maintain the supply air static pressure setpoint.

#### VFD with Bypass

Bypass control is an option that provides full nominal airflow in the event of drive failure. The user must initiate the bypass mode at the HI panel. When in bypass mode, VAV boxes need to be fully open. The self-contained unit will control heating and cooling functions to maintain setpoint from a user-defined zone sensor. Supply air static pressure limit is active in this mode.

For more detailed information on VFD operation, reference the VFD technical manual that ships with the unit.

#### Airside Economizer Option

Units with the airside economizer option are equipped with the necessary control sequences to use outside air for the first



## Operation

stage of cooling, in occupied or unoccupied mode and when ambient conditions are favorable for economizing. Inherent in the unit controller is the ability to suppress the setpoint below the normal unit setpoint. This allows the building to improve comfort levels when possible, and at the same time, optimize building mechanical cooling operation for peak operating efficiency. An outside air temperature and relative humidity sensor are provided to allow monitoring of reference enthalpy and are field installed.

If the unit has the ECEM board, economizer operation enables when the outside air enthalpy is less than 25 BTU's/lb. default (adjustable 19-28 BTU's/lb). During occupied mode, the outside air damper opens to 15% (adjustable 0-100% at the HI) for ventilation purposes. Also, the ability to alter the outside air damper position to compensate for VAV supply air modulation is inherent in the unit controls, and can be enabled by the operator.

If the unit does not have an ECEM board, it will economize when the O/A temperature falls below the O/A economizer setpoint.

The mixing box fabrication is galvanized steel. Opposed low leak damper blades are fabricated from galvanized steel and rotate on rustproof nylon bushings. A factory installed 24V modulating spring return actuator controls both damper positions.

When outdoor conditions are not suitable for economizer cooling, the enthalpy control disables the economizer function and permits the outdoor air damper to open only to the minimum position.

On water-cooled units, compressor operation lockout will not occur at low ambient air temperatures. However, lockout will still occur via low condenser water temperature.

The outdoor air dampers drive fully closed whenever the supply air fan is off, provided there is power to the unit.

### Comparative Enthalpy Control

Comparative enthalpy controls the economizer operation and measures temperature and humidity of both return air and outside air to determine which

source has lower enthalpy. This allows true comparison of outdoor air and return air enthalpy by measurement of outdoor air and return air temperatures and humidities. A factory-installed control board, with field-installed outside and return air temperature and relative humidity sensors, allows monitoring of outside and return air.

---

Note: If comparative enthalpy is not ordered, the standard method is to compare outdoor air enthalpy with the fixed reference enthalpy. The reference enthalpy is set through the human interface panel.

---

Units with comparative enthalpy control are equipped with the necessary control sequences to allow using outside air for the first stage of cooling, in occupied or unoccupied mode and when ambient conditions are favorable for economizing. Inherent in the unit controller is the ability to suppress the setpoint below the normal unit setpoint. This allows the building to improve comfort levels when possible, and at the same time, optimize building mechanical cooling operation for peak operating efficiency.

Economizer operation enables when the outside air enthalpy is 3 BTU/lb less than the return air enthalpy. During occupied mode, the outside air damper opens to 15% (adjustable 0-100%) for ventilation purposes. Also, the ability to alter the outside air damper position to compensate for VAV supply air modulation is inherent in the unit controls, and can be enabled by the operator.

The mixing box fabrication is galvanized steel. Opposed low leak damper blades are fabricated from galvanized steel and rotate on rustproof nylon bushings. A factory installed 24V modulating spring return actuator controls both damper positions.

### Airside Economizers with Traq™ Damper

Outside air enters the unit through the Traq™ damper assembly and is measured by velocity pressure flow rings. The velocity pressure flow rings are connected to a pressure transducer/solenoid assembly, which compensates for temperature swings that could affect the transducer. The ventilation control

module (VCM) utilizes the velocity pressure input, the RTM outdoor air temperature input, and the minimum outside air cfm setpoint to modify the volume (cfm) of fresh air entering the unit as the measured airflow deviates from setpoint.

When the optional preheat temperature sensor is installed at the auxiliary temperature on the VCM and the preheat function is enabled, the sensor will monitor the combined (averaged) fresh air and return air temperatures. As this mixed air temperature falls below the preheat actuate temperature setpoint, the VCM activates the preheat binary output to control a field-installed heater. The output deactivates when the temperature rises 5°F above the preheat actuate temperature setpoint.

Using a field-installed CO<sub>2</sub> sensor with CO<sub>2</sub> reset enabled, as the CO<sub>2</sub> concentration increases above the CO<sub>2</sub> reset start value, the VCM modifies the minimum outside air cfm setpoint to increase the amount of fresh air entering the unit. The setpoint adjusts upward until reaching the CO<sub>2</sub> maximum reset value. The maximum effective (reset) setpoint value for fresh air is limited to the system's operating cfm. As the CO<sub>2</sub> concentration decreases, the effective (reset) setpoint value adjusts downward toward the minimum outside air cfm setpoint. See Figure O-GI-6 for an airflow cfm vs. CO<sub>2</sub> concentration curve.

### Standard Two-Position Damper Interface

Units with the two-position damper interface are provided with a 0-10 VDC control output suitable for controlling a field-provided modulating actuator. In occupied mode, the output drives to the maximum position.

### Airside Economizer Interface

Units with airside economizer interface are equipped with the necessary control sequences to allow using outside air for the first stage of cooling, in occupied or unoccupied mode and when ambient conditions are favorable for economizing. Inherent in the unit controller is the ability to suppress the setpoint below the normal unit setpoint. This allows the building to improve comfort levels when possible, and at the same time, optimize building mechanical cooling operation for



## Operation

peak operating efficiency. An outside air temperature and relative humidity sensor are provided for field installation to monitor reference enthalpy. Economizer operation enables when the outside air enthalpy is less than 25 BTU/lb (adjustable 19-28 BTU/lb.). During occupied mode, the outside air damper opens to 15% (adjustable 0-100%) for ventilation purposes. Also, the ability to alter the outside air damper position to compensate for VAV supply air modulation is inherent in the unit controls, and can be enabled by the operator. An analog 2-10 VDC output (adjustable 0-10 VDC) is provided to modulate the field-provided 30 second damper actuators (adjustable 1-255 seconds).

### Airside Economizer Interface with Comparative Enthalpy

Units with airside economizer interface and comparative enthalpy are equipped with the necessary control sequences to allow using outside air for the first stage of cooling, in occupied or unoccupied mode and when ambient conditions are favorable for economizing. Inherent in the unit controller is the ability to suppress the setpoint below the normal unit setpoint. This allows the building to improve comfort levels when possible, and at the same time, optimize building mechanical cooling operation for peak operating efficiency. A factory-installed control board, with outside and return air

temperature and relative humidity sensors, are provided for monitoring outside and return air. The sensors are field installed. Economizer operation enables when the outside air enthalpy is 3 BTU's/lb. less than the return air enthalpy. During occupied mode, the outside air damper opens to 15% (adjustable 0-100%) for ventilation purposes. Also, the ability to alter the outside air damper position to compensate for VAV supply air modulation is inherent in the unit controls, and can be enabled by the operator. An analog 2-10 VDC output (adjustable 0-10 VDC) is provided to modulate the field-provided 30-second damper actuators (adjustable 1-255 seconds).

### Air-Cooled Condensers

Model SXRF units are designed for use with the remote air-cooled condenser, model CXRC. For more information, see the air-cooled condenser Installation, Owner, and Diagnostic Manual, *CXRC-SVX01A-EN*.

Condenser fans will stage per a user-defined setting. If the condenser is equipped with head pressure control (air modulation on last stage of condenser capacity), the condenser airflow will modulate to maintain condensing temperature setpoint. Condensing temperature is determined by sensors located at each condenser coil.

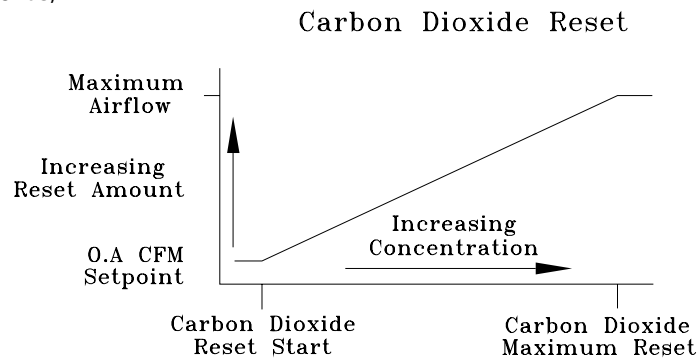

Figure O-GI-6. CO<sub>2</sub> reset function, outside air vs. CO<sub>2</sub>



# Operation

## general information

### Input Devices and System Functions

Following are basic input device and system function descriptions used within the UCM network on IntelliPak self-contained units. Refer to the unit wiring diagrams for specific connections.

#### Water Purge

#### **NOTICE** Proper Water Treatment!

**The use of untreated or improperly treated water in coils may result in scaling, erosion, corrosion, algae or slime. It is recommended that the services of a qualified water treatment specialist be engaged to determine what water treatment, if any, is required. Trane assumes no responsibility for equipment failures which result from untreated or improperly treated water or saline or brackish water.**

During the unoccupied mode, water-cooled units will periodically circulate water through the condensers and waterside economizer if the user has enabled the purge function at the HI. The water purge function circulates water to introduce fresh water-treatment chemicals and help prevent water stagnation. The number of hours between each periodic purge, or purge duration, is user-defined at the HI between 1-999 hours. If the periodic purge timer expires while the unit is in occupied mode, it will wait for the next available unoccupied time before initiating water purge. Contrary, if a request for cooling occurs during a purge sequence, purge will terminate and cooling will commence.

#### Compressor Circuit Breakers

The compressors are protected by circuit breakers that interrupt the compressor power supply if the current exceeds the breakers "must trip" value. During a request for compressor operation, if the compressor module (MCM or SCM) detects a problem outside of its normal parameters, it turns any operating compressor(s) on that circuit off, locks out all compressor operation for that circuit, and initiates a manual reset diagnostic.

#### Compressor Motor Winding Thermostats

A thermostat is embedded in the motor windings of each compressor. Each thermostat opens if the motor windings exceed approximately 221°F. The thermostat resets automatically when the winding temperature decreases to approximately 181°F. Rapid cycling, loss of charge, abnormally high suction temperatures, or the compressor running backwards could cause the thermostat to open. During a request for compressor operation, if the compressor module detects a problem outside of its normal parameters, it turns any operating compressor(s) on that circuit off, locks out all compressor operation for that circuit, and initiates a manual reset diagnostic.

#### Low Pressure Control

Low pressure (LP) control is accomplished using a binary input device. LP cutouts are mounted on the suction lines near the compressors. The LP control contacts close when the suction pressure exceeds  $27 \pm 4$  psig. If the LP control is open when a compressor starts, none of the compressors on that circuit will operate. They are locked out and a manual reset diagnostic initiates. The LP cutouts open if the suction pressure approaches  $7 \pm 4$  psig. If the LP cutout opens after a compressor starts, all compressors operating on that circuit will turn off immediately and will remain off for a minimum of three minutes.

If the LP cutout trips four consecutive times during the first three minutes of operation, the compressors on that circuit will lock out and a manual reset diagnostic initiates.

#### Evaporator Temperature Sensor Frost™

The evaporator temperature sensor is an analog input device used to monitor refrigerant temperature inside the evaporator coil to prevent coil freezing. It is attached to the suction line near the evaporator coil with circuits 1 and 2 connected to the SCM/MCM and circuits 3 and 4 connected to the WSM. The coil frost cutout temperature is factory set at 30°F. It is adjustable at the HI from 25-35°F. The compressors stage off as necessary to prevent icing. After the last compressor stages off, the compressors

will restart when the evaporator temperature rises 10°F above the coil frost cutout temperature and the minimum three minute "off" time elapses.

#### Saturated Condenser Temperature Sensors

The saturated condenser temperature sensors are analog input devices. They are mounted inside a temperature well located on a condenser tube bend on air-cooled units, and in the condenser shell on water-cooled units. The sensors monitor the saturated refrigerant temperature inside the condenser coil and are connected to the SCM/MCM for circuits 1 and 2 (air or water cooled), and WSM for circuits 3 and 4 (only water-cooled).

#### Head Pressure Control

Head pressure control is accomplished using two saturated refrigerant temperature sensors on air-cooled units and up to four sensors on water-cooled units.

**Air-cooled units:** During a request for compressor operation when the condensing temperature rises above the lower limit of the control band, the compressor module (SCM/MCM) sequences condenser fans on. If the operating fans cannot bring the condensing temperature to within the control band, more fans turn on. As the saturated condensing temperature approaches the lower limit of the control band, fans sequence off. The minimum on/off time for condenser fan staging is 5.2 seconds. If the system is operating at a given fan stage below 100% for 30 minutes the saturated condensing temperature is above the efficiency check point setting, a fan stage will be added. If the saturated condensing temperature falls below the efficiency check point setting, fan control remains at the present operating stage. If the fan stage cycles four times within a 10 minute period, the lower limit temperature is redefined as being equal to the lower limit minus the temporary low limit suppression setting. The unit will utilize this new low limit temperature for one hour to reduce condenser fan short cycling.

## Operation

**Water-cooled:** Units without WSE, the condenser valve modulates to maintain an average saturated condenser temperature. Units with WSE, if economizing and mechanical cooling is necessary the economize valve will sacrifice free cooling and modulate to maintain condensing saturated temperature. If not economizing, the condenser valve will modulate to maintain condensing saturated temperature.

Water-cooled units without head pressure control will lock out mechanical cooling at entering condenser water temperatures below 54°F. Mechanical cooling will resume when the entering condenser water temperature exceeds 58°F.

### **Low Ambient Control (Air-Cooled Units Only)**

The low ambient modulating output on the compressor module is functional on all units with or without the low ambient option. When the compressor module stages up to its highest stage (stage 2 or 3 depending on unit size), the modulating output is 100% (10 VDC). When the control is at stage 1, the modulating output (0-10 VDC) controls the saturated condensing temperature to within the programmable condensing temperature low ambient control point.

### **Low Ambient Compressor Lockout (Air-Cooled Units Only)**

The low ambient compressor lockout utilizes an analog input device. When the system is configured for low ambient compressor lockout, the compressors will not operate if the temperature of the outside air falls below the lockout setpoint. When the temperature rises 5°F above the lockout setpoint, the compressors will operate. The setpoint for units without the low ambient option is 50°F. For units with the low ambient option, the setpoint is 0°F. The setpoints are adjustable at the human interface panel.

### **Return Air Temperature Sensor**

The return air temperature sensor is an analog input device used with a return humidity sensor on units with the comparative enthalpy option. The sensor monitors the return air temperature and compares it to the outdoor temperature to establish which temperature is best

suited to maintain cooling requirements. It is mounted in the return air path and connected to the ECEM.

### **Supply Fan Circuit Breaker, Fuses, and Overloads**

The supply fan motor is protected by either circuit breakers fuses or a combination of fuses and overloads, dependent upon unit configuration. Circuit breakers are used on units without a VFD. They will trip and interrupt the motor power supply if the current exceeds the breaker trip value. The RTM shuts all system functions off when detecting an open fan proving switch. Units with a VFD have fuses to protect the VFD and motor. Units with a VFD w/ bypass have fuses to protect VFD circuit and overloads to protect the motor when in bypass.

### **Supply Air Temperature Low Limit**

The supply air temperature low limit function uses the supply air temperature sensor input to modulate the economizer damper to the minimum position if the supply air temperature falls below the occupied heating setpoint temperature.

### **Supply Air Temperature Sensor**

The supply air temperature sensor is an analog input device. It monitors the supply air temperature for supply air temperature control, supply air temperature reset, supply air temperature low limiting, and supply air tempering. It is mounted in the supply air discharge section of the unit and connected to the RTM.

### **Supply Airflow Proving Switches**

This is binary input device used on units to signal the RTM when the supply fan is operating. It is mounted in the supply fan section and is connected to the RTM. During a request for fan operation and if the differential switch opens for 40 consecutive seconds, compressor operation turns off, heat operation turns off, the request for supply fan operation is turns off and locks out, IGV option closes, economizer damper option closes, and a manual reset diagnostic initiates.

### **Low Entering Air Protection Device (LEATPD)**

The low entering air protection device (LEATPD) is a binary input on units with hydronic heat or a waterside economizer. It is optional on water-cooled units.

If the LEATPD is on a unit with factory-installed heat, it is mounted in the heat section and connected to the heat module. If the entering air temperature to the heating coil falls to 40°F, the normally open contacts on the LEATPD close and cause the following events:

- a. the hydronic heat actuator fully opens.
- b. the supply fan turns off
- c. the outside air damper closes
- d. the SERVICE light at the remote zone sensor option turns on.
- e. a LEATPD diagnostic displays at the human interface panel.

If the LEATPD is on a water-cooled unit without factory-installed heat, it is wired to the WSM. It will trip if the entering water temperature falls to 34°F, open the economizer valve, and energize the pump output.

### **High Duct Temp Thermostat Option On Units with an LCI**

The high duct temperature thermostats are binary input devices used on units with a Trane communication interface module (Tracer/LCI-I). They provide a high limit unit shutdown and require a manual reset. The thermostats are factory set to open if the supply air temperature reaches 240°F, or the return air temperature reaches 135°F. Once tripped, the thermostat requires a manual reset. Reset by pressing the sensor's reset button when the air temperature decreases approximately 25°F below the cutout point.

### **Filter Switch**

The filter switch is a binary input device that measures the pressure differential across the unit filters. It is mounted in the filter section and connected to the RTM. A diagnostic SERVICE signal displays at the remote panel if the pressure differential across the filters is at least 0.5" w.c. The contacts automatically open when the pressure differential across the filters decrease to 0.4" w.c. The switch differential is field adjustable between 0.17" to 5.0" w.c. ± 0.05 "

### **High Duct Static Switch Option**

The high duct static switch is field-mounted in the ductwork or plenums with smoke dampers. It will cause a manual reset diagnostic if the duct static exceeds the pre-set static limit. The static limit is adjustable at the HI.

# Operation

## sequence of operation

### Control Sequences of Operation

#### Occupied/Unoccupied Switching

There are four ways to switch occupied/unoccupied:

- (1) Night setback zone sensor
- (2) Field-supplied contact closure (hardwired binary input to RTM)
- (3) Tracer Summit
- (4) Factory-mounted time clock

#### Field Supplied Occupied/Unoccupied Input on the RTM

This input accepts a field supplied switch or contacts closure, such as a time clock, with a rating of 12 mA at 24 VDC minimum.

#### Tracer Summit System

The Tracer Summit system can control the occupied/unoccupied status of the self-contained unit.

#### Factory Mounted Time Clock

A time clock can control the occupied/unoccupied status of the self-contained unit.

### Unoccupied Sequence of Operation

The unoccupied mode helps conserve energy during times when a building is usually unoccupied. When in unoccupied mode, the unit will control to the unoccupied setpoints (usually a lower

heating setpoint and higher cooling setpoint). Setpoints can be programmed at the HI, Tracer Summit, or the night setback zone sensor.

The unit enters the unoccupied mode when the RTM receives a closed signal on the unoccupied input for more than five seconds.

For units with supply air temperature control entering unoccupied mode, the following sequence will occur:

- Heating/cooling functions cease and the economizer option closes fully. The supply fan shuts down for proper cool-down time of the heat exchanger. However, the supply fan may remain on for a short period of time.
- After the supply fan shuts down, the occupied/unoccupied relay energizes and the IGV option fully opens. Also, the VAV box stroke time begins. The VAV box stroke time is field adjustable to allow time for VAV boxes to go to the full open airflow position.
- After the max VAV box stroke time expires and the IGV's are fully open, the supply fan, economizer (if enabled), compressors, and heat are enabled to satisfy the unoccupied zone temperature setpoints.

---

Note: Unoccupied economizer operation can be enabled or disabled at the HI or using Tracer Summit.

---

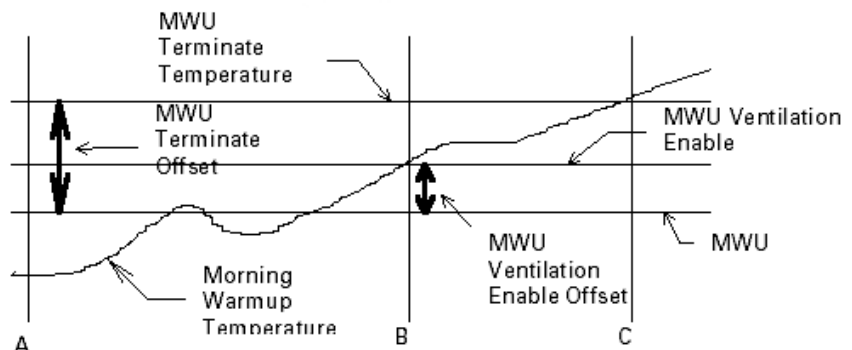

Figure O-SO-1. Typical cycling morning warmup cycle

## sequence of operation

# Operation

For units without volume control entering unoccupied mode, the following sequence will occur:

- The occupied/unoccupied relay energizes and the economizer option fully closes.
- The fan mode is set to auto and the unit will control to the unoccupied zone temperature setpoints.

With MWU enabled at the HI, if the zone temperature is below the MWU setpoint, the unit enters the MWU mode.

### Morning Warmup

This feature can be enabled at the HI, and can be used with factory or field-installed heat. If MWU is not required disable the function in the setup menu at the HI. MWU transitions the zone from unoccupied to occupied. It will heat until the MWU setpoint is met. The unit is then released to occupied mode. Supply duct static pressure is maintained during this sequence. MWU can be set (at the HI) to function as either full or cycling capacity.

### Full Capacity Morning Warmup (MWU)

Full capacity morning warmup uses full heating capacity to heat the zone as quickly as possible. Full heating capacity is provided until the morning warmup setpoint is met. At this point, the unit is released to daytime mode.

### Cycling Capacity Morning Warmup (MWU)

Cycling capacity morning warmup provides a more gradual heating to overcome "building sink" as the zone is heated. Normal zone temperature control with varying capacity is used to raise the zone temperature to the MWU zone temperature setpoint. This method of warmup is used to overcome the "building sink" effect.

Reference Figure O-SO-1 on page 73 for a pictorial explanation of the cycling MWU sequence. Cycling capacity MWU will heat until MWU temperature setpoint

is reached. Next a 60 minute timer begins. If the building load reaches the MWU ventilation setpoint, or the 60 minutes expire, whichever is first, the airside economizer will control to the minimum position. MWU will end when the zone temperature rises above the MWU terminate setpoint.

### Timed Override Activation - ICS™

This function is operational whenever the unit's RTM module is used as the zone temperature sensor source, which can be set at the HI panel. When this function is initiated by the push of the override button on the zone sensor, the unit will switch to the occupied mode. Unit operation (occupied mode) during timed override is terminated by a signal from Tracer.

### Timed Override Activation - Non-ICS

This function is active whenever the unit's RTM module board is selected as the zone temperature source, which can be set at the human interface panel. When this function is initiated by the push of the override button on the zone sensor, the unit will switch to the occupied mode. Automatic cancellation of the timed override mode occurs after three hours of operation.

### VAV Drive Max Output

This is a single-pole, double-throw relay rated at a maximum voltage of 24 vac, two amps max. The relay contacts of this relay switch when the unit goes from the occupied mode to the unoccupied mode by means of the unoccupied binary input, night setback zone sensor, or Tracer Summit. The contacts will stay switched during the unoccupied and morning warmup mode. They will return to the position shown on the unit wiring diagram when the unit returns to the occupied mode. The intent of this binary output is to signal the VAV boxes or other terminal devices to go to a full open airflow position.



# Operation

## sequence of operation

### Occupied Sequence

All setpoints can be adjusted using the HI panel. Also, cooling/heating setpoints can be adjusted in the zone, if using one of the zone sensor options (BAYSENS020, BAYSENS021, BAYSENS108, BAYSENS110, BAYSENS019, or BAYSENS074). For a complete list of unit setpoint default values and ranges, see the *IntelliPak Self-Contained Programming Guide, PKG-SVP01B-EN*.

#### Occupied Zone Temperature - Cooling

The unit transitions from unoccupied to occupied when the occupied/unoccupied input on the RTM is open for more than five seconds after having been closed. This input can be received from Tracer Summit, the remote NSB zone sensor, the timed override function, or a field supplied contact. Dependent on unit options and the HI programming, the following sequence will occur:

- The unit will begin MWU and then switch to the occupied mode after the MWU setpoint is met.
- Purge will be enabled by Tracer Summit. Then Tracer Summit will enable the occupied mode.
- The unit will switch from unoccupied to occupied control immediately.

Upon entering occupied mode, the IGTV option will close while the supply fan remains on. The occupied/unoccupied relay will de-energize.

#### Zone Temperature Control (Unit Model Number Digit 9 = 4 or 5)

A zone sensor located directly in the space sends input to the RTM while the CV unit is in occupied cooling mode. When the unit is in occupied cooling, the RTM controls the zone temperature within the cooling setpoint deadband by modulating the economizer option and/or staging mechanical cooling on and off as required.

#### Supply Air Temperature Control (Unit Model Number Digit 9 = 1, 2, 3, or 6)

When the VAV unit is in occupied cooling, the RTM controls the supply air temperature to the specified supply air cooling setpoint by modulating the economizer option and/or staging mechanical cooling on and off as required. The changeover relay contacts (field supplied) must be open on units with hydronic heat for cooling to operate.

#### Cooling

Upon entering occupied mode, the RTM receives an input from either the HI, RHI, Tracer Summit, or the GBAS to start the supply fan. The RTM supply fan contacts close and energize the supply fan contactor. On VAV units with IGTV, the fan delays until the IGTV fully close. When the supply fan starts, the fan proving switch closes, signaling the RTM that airflow is established. Depending on unit options, either the IGTV will begin to drive open, the VFD will ramp the fan, and/or the airside economizer dampers will open to the user-defined minimum position.

When a cooling request is sent to the RTM from the zone sensor, the RTM evaluates the system operating conditions using the supply air and outdoor temperature input before sending the request to the MCM for mechanical cooling. If outdoor conditions (temperature and humidity) are suitable or the EWT is within specified setpoints, the RTM will attempt to use "free cooling" without using any compressors. The RTM will use either the airside or waterside economizer option. When outdoor air conditions are not suitable, only mechanical cooling will function and outside air dampers will remain at their minimum position. If the unit does not have an economizer, mechanical cooling will operate to satisfy cooling requirements.

#### Units With Economizer

If the entering condenser water temperature (units with a WSE) or the outside air enthalpy (units with an ASE) is appropriate to use "free cooling," the economizer will attempt to satisfy the cooling zone temperature setpoint.

Note: When using an ASE with economizer enabled, O/A temperature enable can be used instead of comparative enthalpy if the O/A temperature falls below the economizer setpoint.

Then compressors will stage on as necessary to maintain supply air temperature setpoint, which is user-defined at the HI. Minimum on/off timing of compressors prevents rapid cycling.

When both airside and waterside economizers are on a single unit, priority must be set at the HI. The economizer

with the highest priority attempts cooling first. Once it is operating at its maximum, and if additional cooling is necessary, the other economizer enables before mechanical cooling begins.

#### Cooling/Waterside Economizer

Waterside economizing enables when the unit's entering water temperature is below the unit's entering mixed air temperature by 4°F plus the user adjustable economizer approach temperature. The approach temperature default is 4°F.

Waterside economizing disables when the unit's entering water temperature is not below the unit's entering mixed air temperature by at least the water economizer approach temperature (default value of 4°F). The economizer acts as the first stage of cooling. If the economizer is unable to maintain the zone (CV units) or supply air (VAV units) temperature setpoint, the compressor module will bring on compressors as required to meet the setpoint.

#### Cooling/Airside Economizer

On units with an airside economizer, a call for cooling will modulate the fresh air dampers open. The rate of economizer modulation is based on deviation of the zone temperature from setpoint; i.e., the further away from setpoint, the faster the fresh air damper will open. The first stage of cooling will start after the economizer reaches full open.

Note: The airside economizer will only function freely if ambient conditions are below the enthalpy control settings or below the return air enthalpy if unit has comparative enthalpy installed. If outside air is not suitable for "economizing," the fresh air dampers drive to the minimum open position. A field adjustable, factory default setting at the HI panel or Tracer Summit can provide the input to establish the minimum damper position.

When outdoor air conditions are above the setpoint or comparative enthalpy control setting, only mechanical cooling will function and outside air dampers will remain at their minimum position.

## sequence of operation

# Operation

### **Mechanical Cooling**

If the zone temperature cannot be maintained within the setpoint deadband using the economizer option or if there is no economizer, the RTM sends a cooling request to the MCM. The compressor module checks the compressor protection circuit before closing stage one. After the first functional stage starts, the compressor module monitors the saturated refrigerant temperature and closes the condenser fan output contact when the saturated refrigerant temperature rises above the lower limit setpoint.

### **Air-Cooled Units Only**

The compressor module closes the condenser fan output contact when the saturated refrigerant temperature rises above the lower limit setpoint.

### **Water-Cooled Units Only**

The WSM modulates the condenser coil water valves to maintain condenser temperature, if applicable. Otherwise, it will check the entering condenser water temperature to ensure it is greater than 54°F or if not, it will lock out cooling.

### **Auto Changeover (Units with Heat Only)**

When the system mode is in auto, the mode will change to cooling or heating as necessary to satisfy the zone cooling and heating setpoints. The zone cooling and heating setpoints can be as close as 2°F (1.1°C).

### **Occupied Zone Temperature - Heating**

Relies on input from a sensor directly in the space, while a system is in occupied heating mode or an unoccupied period, to stage electric heat on and off or modulate the hydronic heating valve as required to maintain the zone temperature within the heating setpoint deadband. The supply fan will operate when there is a request for heat.

### **Electric Heat**

On units with electric heat, the zone temperature can be controlled to a heating setpoint during the occupied mode by cycling a single stage electric heater. An interface is provided for field supplied single stage electric heat. The zone temperature heating setpoint and deadband are user defined at the HI panel.

### **Hydronic Heat: Hot Water or Steam**

On units with hot water or steam heating, the zone temperature can be controlled to a heating setpoint during the occupied mode. The zone temperature heating setpoint and deadband are user defined at the HI panel or zone sensor. VAV occupied heating initiates by closing a field-supplied switch or relay contacts connected to the changeover input on the RTM. Supply air static pressure is maintained.

### **Supply Air Setpoint Reset (VAV Units Only)**

Supply air reset can be used to adjust the supply air temperature setpoint on the basis of a zone temperature or outdoor air temperature. Supply air reset adjustment is available at the HI panel for supply air heating and supply air cooling control.

### **Reset based on outdoor air temperature**

Outdoor air cooling reset is sometimes used in applications where the outdoor temperature has a large effect on building load. When the outside air temperature is low and the building cooling load is low, the supply air setpoint can be raised, thereby preventing subcooling of critical zones. This reset can lower usage of mechanical cooling, thus savings in compressor kW, but an increase in supply fan kW may occur.

Outdoor air heating reset is the inverse of cooling, with the same principles applied.

For both outdoor air cooling reset and heating reset, there are three user defined parameters that are adjustable through the human interface panel.

- Beginning reset temperature
- Ending reset temperature
- Maximum amount of temperature reset

### **Reset based on zone temperature**

Zone reset is applied to the zone(s) in a building that tends to overcool or overheat. The supply air temperature setpoint is adjusted based on the temperature of the critical zone(s). This can have the effect of improving comfort and/or lowering energy usage. The user-defined parameters are the same as for outdoor air reset.

### **Supply Air Tempering (Hot Water and Steam VAV Units Only)**

When supply air temperature falls below the supply air temperature deadband low end, the heating valve modulates open to maintain the minimum supply air temperature setpoint.

### **Daytime Warmup (Units with Supply Air Temperature Control Only)**

During occupied mode, if the zone temperature falls to a preset, user-defined zone low limit temperature setpoint, the unit is put into daytime warmup. The system changes over to CV heating, the VAV boxes drive full open. However, unit airflow modulation control operates to maintain duct static setpoint, and full heating capacity is provided until the daytime warmup setpoint is reached. The unit is then returned to normal occupied mode.

### **Supply Air Tempering**

Supply air tempering is available on units without volume control and with hot water, steam, or electric heat or units with supply air temperature control with steam or electric heat. When the unit is in heat mode but not actively heating, if the supply air temperature drops to 10°F (5.5°C) below the occupied zone heating temperature setpoint, electric heat will stage on or the hydronic valve will modulate to maintain a minimum supply air temperature. The unit transitions out of heat mode if the supply air temperature rises to 10°F (5.5°C) above the occupied zone heating temperature setpoint.

### **Changeover**

This mode only functions on units with supply air temperature control with hydronic heat. When the changeover binary input is closed the unit will control to a discharge air heating setpoint. This setpoint is entered from the HI, and can be a higher temperature than the supply air cooling setpoint. This function maintains duct static pressure.



# Operation

## sequence of operation

### Compressors

Units use two sizes of hermetic scroll compressors, 10 and 15 hp, and can use from two to six compressors. When viewing the front of the unit, compressors are identified A through B from left to right. The second compressor from the left, or B compressor, is always the first to come on, unless locked out for a malfunction or shut off on frost protection. Refer to Table O-SO-1 for compressor cycling stages and Table O-SO-3 on page 78 for percent cooling capacity by stage.

The control system logic permits compressor operation only after the supply fan is on. If the supply fan shuts down, compressors will not operate. Units without head pressure control (units with intermediate piping packages) will lock out mechanical cooling when the entering condenser water temperature falls below 54°F. Mechanical cooling will resume when the entering condenser water temperature exceeds 58°F.

When there are more than two compressors in an air cooled unit, the first two

compressors are manifolded together. If there are four compressors, the second two are manifolded.

#### Compressor Cycling

Compressors cycle to maintain the operating state required by the temperature controls. In the event of a compressor failure, the next available compressor turns on. Refer to Table O-SO-1 for compressor cycling by unit model and tons.

During normal conditions, compressors will not shut off until they have been on for at least three minutes and will not turn on until they have been off for at least three minutes. Normal operating conditions are established on an individual compressor basis. When a compressor starts, its timer also starts. The compressor evaporator circuit frost protection can override the "minimum" timer and reduce the five minute minimum required time period.

When the unit is powered up, or manually reset there will be a three to eight minute delay before the first compressor may be

turned on as requested by the unit temperature control algorithm.

#### Compressor Lead/Lag Operation

Compressor lead/lag is a user-selectable feature at the HI panel and is available on all units. After each request for compressor operation, the lead refrigeration circuit or compressor switches, thereby causing a more equitable or balanced run time among compressors.

When lead/lag is enabled, each time the system cycles, it will alternate between the standard compressor staging and the lead/lag staging. Using Table O-SO-1, a SXWG 30-ton unit will first stage compressor B then A, then AB for first cycle and A, then AB for the second cycle. Appropriate condenser valves (water-cooled and condenser fans (air-cooled) will stage with appropriate compressors to maintain saturated condensing temperature. Enabling lead/lag may drop a cooling stage when compared to standard staging. See Table O-SO-1 for compressor staging.

**Table O-SO-1. Compressor Stages.**

Unit Size	Refrigerant Circuit Type Model # Digit 5	Compressor HP by Stage		Standard Compressor Staging	Lead/Lag Compressor Staging	SCM or MCM
		A	B			
SXWG 20, 25 SXRG 20	Independent	10	10	B/AB	A/AB	MCM
SXWG 30 SXRG 25	Independent	15	10	B/A/AB	A/AB	MCM
SXWG 35 SXRG 32	Independent	15	15	B/AB	A/AB	MCM



## sequence of operation

# Operation

### Compressor Safety Devices

The compressors have motor temperature cutout switches in the motor windings. These switches are provided to take the compressors off line during high motor winding temperature conditions.

If a compressor low pressure cutout opens during compressor start-up, the UCM will not shut the compressor off during the first two to three minutes after start-up. This prevents possible nuisance trips during low ambient start conditions. See Table O-SO-2.

Each compressor's discharge line contains a high pressure cutout. Under abnormal operating conditions, the cutout will open to stop compressor operation.

**Table O-SO-2. Pressure cutouts**

Unit Model	High Pressure Cutout	Low Pressure Cutout
SXWE	360/270	20/35
SXRF	405/350	12/27

### Step Control

Steps of mechanical cooling are control based on supply air or zone temperature. See Table O-SO-1 for compressor staging.

Capacity is based on an integrating control concept. The unit capacity matches the existing load and maintains an average supply air temperature within the supply air setpoint temperature control band region.

The supply air temperature control band is centered around supply air temperature setpoint and is adjustable from 2 to 12°F. In a steady state, the unit will either maintain a constant level of cooling capacity with the supply air temperature within the control band, or the highest active cooling level will cycle to provide an average supply air temperature equal to the setpoint.

If the supply air temperature swings outside the limits of the control band, the mechanical cooling capacity will increase or decrease by one level accordingly. The change occurs by integrating the temperature offset from the control band limit.

A minimum time delay of five minutes follows each change in cooling level. This time delay promotes stability by allowing the system to respond to the change before any further control action occurs. As the supply air temperature approaches setpoint, the time duration between changing levels of cooling capacity increases.

See Figure O-SO-2 for the typical unit operating curve. Figure O-SO-3 shows typical unit performance when supply air temperature swings exceed the control band limits.

Adjust the supply air temperature control band according to the desired unit performance. Increasing the control band reduces the equipment cycle rate and increases the maximum potential supply air temperature deviation from setpoint. Conversely, decreasing the control band reduces the maximum potential temperature deviation, but increases the compressor cycle rate.

Follow these recommendations concerning the supply air temperature control band settings based on expected unit sizing:

- 2 Cooling stage unit: 9°F
- 3 Cooling stage unit: 7°F
- 4 Cooling stage unit: 6°F

### Low Ambient Compressor Lockout

This function will lock out the compressor if the outdoor air temperature sensor reads an outdoor temperature below the low ambient compressor lockout temperature setpoint. This setpoint is adjustable at the human interface panel. Compressors will lock out when outdoor air temperature falls below that selected temperature and will start again when the temperature rises 5°F above the setpoint.

### Evaporator Coil Frost Protection FROSTAT™

The FROSTAT™ system eliminates the need for hot gas bypass. It utilizes an evaporator temperature sensor mounted on the suction line near the TXV bulb of each circuit to protect the evaporator from freezing.

If the evaporator temperature approaches the specified setpoint (adjustable between 25 and 35°F at the HI) the compressor(s) will cycle off. The supply fan remains on to help de-ice the coil. The compressors will restart when the evaporator temperature has risen 10°F above the specified cutout temperature and when the compressor(s) have been off a minimum of three minutes. This prevents rapid cycling of the compressors.

# Operation

## sequence of operation

### Service Valve Option

If ordered, service valves are factory installed on each circuit before and after the compressor to allow compressor isolation for servicing.

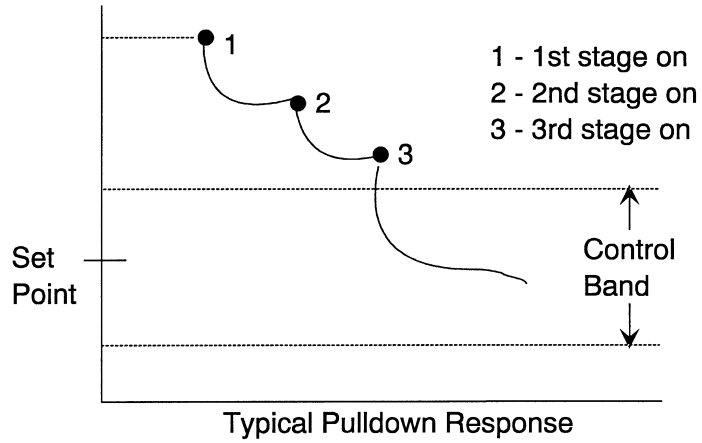

Figure O-SO-2. Typical pulldown curve for unit operating properly within control band

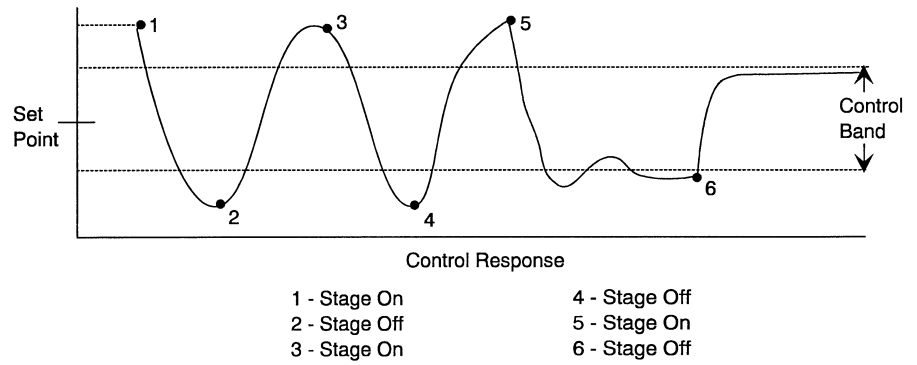

Figure O-SO-3. Typical pulldown curve for unit operating improperly outside control band



# Maintenance

## general information

**Table M-GI-1. SCWG/SIWG/SCRG/SIRG General Maintenance Data**

Unit Size	Water-Cooled Units				Air-Cooled Units		
	20	25	30	35	20	25	32
<b>Compressor Data</b>							
Quantity	2	2	1/1	2	2	1/1	2
NominalTon/Comp	10	10	10/15	15	10	10/15	15
Circuits	2	2	2	2	2	2	2
<b>Evaporator Coil Data</b>							
Rows	2	4	4	4	3	4	4
Sq. Ft.	22.5	25.0	25.0	25.0	25.0	25.0	25.0
FPF	144	144	144	144	144	144	144
<b>Condenser Data</b>							
Minimum GPM w/o Econ	36	36	46	54	-	-	-
Minimum GPM w/ Econ	41	41	60	65	-	-	-
Maximum GPM	80	80	102	119	-	-	-
<b>Evaporator Fan Data</b>							
Quantity	2	2	2	2	2	2	2
Size (Dia. x width - inches)	12 <sup>5</sup> / <sub>8</sub> " x 8"	12 <sup>5</sup> / <sub>8</sub> " x 9"	12 <sup>5</sup> / <sub>8</sub> " x 11"	12 <sup>5</sup> / <sub>8</sub> " x 11"	12 <sup>5</sup> / <sub>8</sub> " x 8"	12 <sup>5</sup> / <sub>8</sub> " x 9"	12 <sup>5</sup> / <sub>8</sub> " x 11"
Minimum HP	5	5	5	5	5	5	5
Maximum HP	20	25	25	25	20	25	25
Minimum Design CFM	6350	7250	7250	7250	7250	7250	7250
Maximum Design CFM	8500	10,625	12,750	14,875	8500	10,625	13600
<b>R-22 Refrigerant Data</b>							
EER	12.6	13.9	13.4	12.5	10.3	10.7	10.1
IPLV	13.2	14.1	12.9	12.2	11.4	11.4	10.4
<b>Refrigerant Charge - lbs.</b>							
Circuit A	25	25	27	27	-	-	-
Circuit B	25	25	25	27	-	-	-
Capacity Steps - %	100/53/0	100/53/0	100/65/47/0	100/53/0	100/52/0	100/66/47/0	100/52/0
<b>407C Refrigerant Data</b>							
EER	11.6	13.2	12.3	11.3	-	-	-
IPLV	12.3	13.5	12.2	11.5	-	-	-
<b>Refrigerant Charge - lbs</b>							
Circuit A	23.5	23.5	26.5	26.5	-	-	-
Circuit B	23.5	23.5	23.5	26.5	-	-	-
Capacity Steps - %	100/53/0	100/53/0	100/65/42/6	100/53/0	-	-	-
<b>Filter Data</b>							
Quantity	4	4	4	4	4	4	4
Size (inches)	(16x25x2)	(16x25x2)	(16x25x2)	(16x25x2)	16x25x2	16x25x2	16x25x2
Quantity	4	4	4	4	4	4	4
Size (inches)	20x25x2	20x25x2	20x25x2	20x25x2	20x25x2	20x25x2	20x25x2
<b>CCRC/CIRC Condenser Match</b>							
	-	-	-	-	20	29	32

**Notes:**

1. Compressors are Trane 3D® scroll.
2. EER and IPLV are rated in accordance to the ARI Standard 340/360-93 for large unitary equipment. Based on 80/67°F (26.7/19.4°C) to the evaporator coil, nominal airflow and 85-95°F (29.4-35°C) condenser water.
3. All units operate with R-22. Units ships with full operating charge.
4. Maximum cfm limits are set to prevent moisture carryover on the evaporator coil.
5. Minimum cfm limits are set to ensure stable thermal expansion valve operation at low load conditions.
6. Filter sizes are for units without hot water or steam heating coils

**Table M-GI-2. SCWG/SIWG/SCRG/SIRG Self-Contained Heating Coil Maintenance Data**

Filter Data for Heating Coil						
Quantity	4					
Size (inches)	20x18x2					
Size (mm)	(508x457x51)					
Quantity	8					
Size (inches)	20x20x2					
Size (mm)	(508x508x51)					
Coil Data	Type	Rows	No. - Size (in)	No. - Size (mm)	fpf	
Steam Coil	NS	1	2 - 24 x 58	2 - 609.6x1473.2	42	
Hot Water Coil	WC	1	2 - 24 x 58	2 - 609.6x1473.2	80	

Notes: 1. Hot water and steam heating coils have Prima-Flo® fins and do not have turbulators. 2. For coil capacities, use TOPSS™ (Trane Official Product Selection Program). 3. Full capacity coils consist of two coils stacked and piped in parallel.



# maintenance procedures

## Maintenance

is this correct?

### Maintenance Procedures

#### Air Filters

Filter access doors are on the unit's left side. Filter access for the 2" filter rack on optional steam and hot water coils and airside economizers is also on the left side

of the unit. To replace throwaway filters, remove the dirty elements and install new filters with the filter's directional arrows pointing toward the fan. Verify that no air bypasses the filters. See Figures O-M-1 and O-M-2 for proper filter placement.

without steam or hot water coil

18 x 20	18 x 20	18 x 20	18 x 20
20 x 20	20 x 20	20 x 20	20 x 20
18 x 20	18 x 20	18 x 20	18 x 20

Note: All filters are 2". These views are from the back of the unit (L-R).

with steam or hot water coil

16 x 20	16 x 20	16 x 20	16 x 20
20 x 20	20 x 20	20 x 20	20 x 20
18 x 20	18 x 20	18 x 20	18 x 20

Note: All filters are 2". These views are from the back of the unit (L-R).

Figure M-MP-1. Unit Filter Sizes and Placement for SXVG 20-38 tons or SXRG 20-40 tons

### WARNING

#### Hazardous Voltage w/Capacitors!

Disconnect all electric power, including remote disconnects before servicing. Follow proper lockout/tagout procedures to ensure the power cannot be inadvertently energized. For variable frequency drives or other energy storing components provided by Trane or others, refer to the appropriate manufacturer's literature for allowable waiting periods for discharge of capacitors. Verify with an appropriate voltmeter that all capacitors have discharged. Failure to disconnect power and discharge capacitors before servicing could result in death or serious injury.

Note: For additional information regarding the safe discharge of capacitors, see PROD-SVB06A-EN or PROD-SVB06A-FR.

## Maintenance

### Inspecting and Cleaning the Drain Pan

Check the condensate drain pan and drain line to ensure that the condensate drains properly at least every six months or as dictated by operating experience.

If evidence of standing water or condensate overflow exists, take steps to identify and remedy the cause immediately. Refer to the trouble shooting section of this manual for possible causes and solutions.

#### **WARNING**

#### **Hazardous Voltage w/Capacitors!**

**Disconnect all electric power, including remote disconnects before servicing. Follow proper lockout/tagout procedures to ensure the power cannot be inadvertently energized. For variable frequency drives or other energy storing components provided by Trane or others, refer to the appropriate manufacturer's literature for allowable waiting periods for discharge of capacitors. Verify with an appropriate voltmeter that all capacitors have discharged. Failure to disconnect power and discharge capacitors before servicing could result in death or serious injury.**

**Note: For additional information regarding the safe discharge of capacitors, see PROD-SVB06A-EN or PROD-SVB06A-FR.**

Clean drain pans using the following procedure:

1. Disconnect all electrical power to the unit.
2. Don the appropriate personal protective equipment (PPE).
3. Remove all standing water.
4. Use a scraper or other tools to remove and solid matter. Remove solid matter with a vacuum device that utilizes high efficiency particulate arrestance (HEPA) filters with a minimum efficiency of 99.97% at 0.3 micron particle size.

5. Thoroughly clean the contaminated area(s) with a mild bleach and water solution or an EPA-approved sanitizer specifically designed for HVAC use. Carefully follow the sanitizer manufacturer's instructions regarding product use.
6. Immediately rinse the drain pan thoroughly with fresh water to prevent potential corrosion from the cleaning solution.
7. Allow the unit to dry thoroughly before putting the system back into service.
8. Properly dispose of all contaminated materials and cleaning solution.

### Inspecting and Cleaning the Fan

Inspect the fan section every six months or more frequently if operating experience dictates. Clean accumulated dirt and organic matter on the fan interior surfaces following the procedure below:

1. Disconnect all electrical power to the unit.
2. Wear the appropriate personal protective equipment (PPE).
3. Use a portable vacuum with HEPA filtration to remove the loose dirt and organic matter. The filter should be 99.97% efficient at 0.3 micron particle size.
4. Thoroughly clean the fan and associated components with an industrial cleaning solution. Carefully follow the cleaning solution manufacturer's instructions regarding personal protection and ventilation when using their product.
5. Rinse the affected surfaces thoroughly with fresh water and a fresh sponge to prevent potential corrosion of metal surfaces.
6. Allow the unit to dry completely before putting it back into service.
7. Properly dispose of all contaminated materials and cleaning solution.

## Maintenance

### Variable Frequency Drive (VFD)

The VFD access panel is hinged to allow service access to the fan motor and belt drive components that are located behind it. To swing the panel open:

- Remove the unit center cover panel to the left of the VFD panel.
- Remove and discard the sheet metal shipping screws along the top and bottom edges of the VFD panel.
- Disconnect the communications cable from the keypad on the VFD door panel.
- Turn the two slotted-head fasteners on the right edge of the VFD panel fully counterclockwise.
- Pull on the handle to swing the panel 180°.

To close and reattach the panel, reverse the procedures listed above.

Note: To secure the panel in the open position during service procedures, attach the chain mounted to the cabinet frame behind the unit center cover panel to the chain retainer notch on the edge of the VFD panel.

Note: Verify that all wires are in their proper position and not rubbing before replacing the panel.

Note: Panel weight rating = 225 lbs. total, including factory-installed components.

### Supply Fan

#### Fan Drive

Perform the following procedures according to the "Periodic Maintenance Check List."

### **⚠**WARNING

#### Hazardous Voltage w/Capacitors!

Disconnect all electric power, including remote disconnects before servicing. Follow proper lockout/tagout procedures to ensure the power cannot be inadvertently energized. For variable frequency drives or other energy storing components provided by Trane or others, refer to the appropriate manufacturer's

literature for allowable waiting periods for discharge of capacitors. Verify with an appropriate voltmeter that all capacitors have discharged. Failure to disconnect power and discharge capacitors before servicing could result in death or serious injury.

**Note:** For additional information regarding the safe discharge of capacitors, see PROD-SVB06A-EN or PROD-SVB06A-FR.

1. Rotate the fan wheel to ensure it turns freely in the proper direction and is not rubbing on the fan housing, inlet, or inlet guide vanes. If necessary, center the fan wheel again.
2. Check the position of both shafts. Fan and motor shafts should operate parallel to each other for maximum belt and bearing life. Shim as necessary under the motor or fan bearings to obtain proper alignment.
3. Check the fan motor sheave alignment with straight edge or a tightly pulled string. For sheaves of different widths, place a string in the center groove of

each sheave and pull it tight for a center line. See Figure M-MP-6 for recommended torques.

4. Once the sheaves are properly aligned, tighten sheave set screws to proper torque. See Tables M-MP-1 and M-MP-2 for recommended torques.
5. Check belt tension. Refer to the "Measuring Belt Tension" section.
6. If required, adjust belt to the minimum recommended tension. Refer to "Adjusting Belt Tension" section.
7. Retighten bearing set screws to the proper torques after aligning the sheaves. See Tables M-MP-1 and M-MP-2 for proper torques.
8. Check the fan bearing locking collars for tightness on the shaft. To tighten the locking collar, loosen the set screw and slide the collar into its proper position over the extended end of the inner case. Tighten the set screw to the torque value in Tables M-MP-1 and M-MP-2.
9. During air balancing, verify the sheave alignment, belt tension, and that the shaft is parallel.

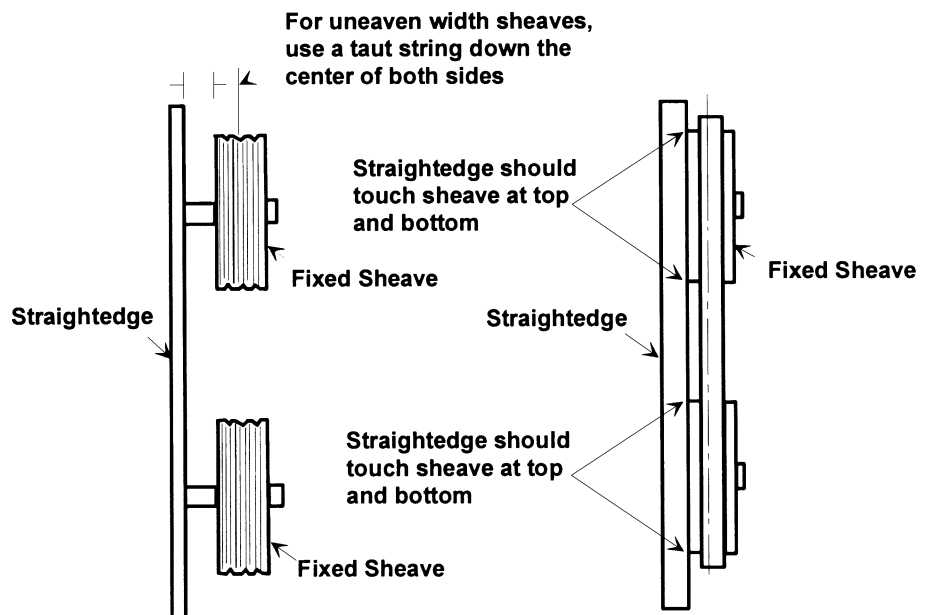

Figure M-MP-4. Fan shaft and motor sheave alignment

# Maintenance

## maintenance procedures

### Fan Bearings

The opposite drive end bearing is a special bearing with close tolerance fit of balls and races. Replace this bearing with the same part number as the original bearing. Follow the fan bearing lubrication schedules in Tables M-MP-1 and M-MP-2. Use Table M-MP-3 to reference compatible fan bearing grease for specific bearings.

**Table M-MP-1. Baldor Fan Bearing Lubrication Schedule**

Baldor	Rated Speed, rpm			
Nema/ (IEC) Frame Size	3600	1800	1200	900
up to 210 incl. (132)	5500 hrs	12,000 hrs	18,000 hrs	22,000 hrs
over 210 to 280 incl. (180)	3600 hrs	9500 hrs	15,000 hrs	18,000 hrs
over 360 to 5800 incl. (300)	2200 hrs	3500 hrs	7400 hrs	10,500 hrs

**Table M-MP-2. AO Smith Bearing Lubrication Schedule**

Speed Service	Frame	Standard Service	Severe Service	Extreme
Over 1800 rpm	All	6 mths	3 mths	3 mths
1800 rpm	140-180	3 yrs	1 yr	6 mths
	210-280	2 1/2 yrs	10 1/2 mths	5 1/2 mths
	320-360	2 yrs	9 mths	4 1/2 mths
	400-440	1 1/2 yrs	8 mths	4 mths

Note: Service standard - 8 hrs/day, normal to light loading, 100°F ambient temp. max.  
 Severe service - 24 hrs/day, shock loading, vibration, dirt or dust, 100 to 150°F ambient temp.  
 Extreme service - heavy shock or vibration, dirt or dust, 100 to 150°F ambient temp.

**Table M-MP-3. Compatible Fan Bearing Grease**

Motor Vendor	Recommended Oil
AO Smith	Exxon Polyrex EM Chevron SRI 2 Dolium R Grease Chevron Black Perl EP1
Baldor	Exxon Polyrex EM Texaco Polystar Rykon Premium #2 Pennzoil Pen 2 Lube Chevron SRI

# Maintenance

## maintenance procedures

### Fan Belt Tension

Note: Check fan belt tension at least twice during the first days of new belt operation since there is a rapid decrease in tension until belts are run-in.

Proper belt tension is necessary to endure maximum bearing and drive component life and is based on fan brake horsepower requirements. If frayed or worn, replace belts in matched sets.

### Measuring Belt Tension

Measure fan belt tension with a Browning, Gates, or equivalent belt tension gauge. Determine deflection by dividing the belt span distance (in inches) by 64. See Figure M-MP-6. Follow the procedure below to measure belt tension.

1. Measure belt span between centers of sheaves and set the large "O" ring of the tensioning gauge at  $\frac{1}{64}$  inch for each inch of belt span.
2. Set the load "O" ring at zero.
3. Place the large end of the gauge at the center of the belt span. Press down until the large "O" ring is even with the top of the belt line or the next belt as in Figure M-MP-6. Place a straight edge across the sheaves as a reference point. See Figure M-MP-4.
4. Remove the gauge. Note that the load "O" ring now indicates a number on the plunger scale. This number represents pounds of force required to deflect the belt.
5. Check the reading from step 4 against the values given in Table M-MP-4. If necessary, readjust belt tension.

**Table M-MP-4. Fan shaft bearing torques**

setscrew size	hex-size across flats	recommended torque	
		in-lb	ft-lb
1/4"-20	1/8"	180	15
5-16"-18	5-32"	402	33.5

**Table M-MP-5. Fan hub and sheave torques**

unit size	fan dia.	setscrew size	torque (ft-lbs)
SCWF 20	16.5"	$\frac{5}{16}$ "	12
SCWF 22			
SCWF 25			
SCRF 20			
SCWF 29	18"	$\frac{5}{16}$ "	12
SCWF 32			
SCRF 25			
SCRF 30			
SCWF 35	20"	$\frac{5}{16}$ "	14
SCWF 38			
SCRF 30			
SCRF 35			
SCWF 42	25"	$\frac{3}{8}$ "	24
SCWF 46			
SCWF 52			
SCWF 58			
SCRF 40	27"	$\frac{3}{8}$ "	24
SCRF 50			
SCWF 65			
SCWF 72			
SCWF 80			
SCRF 60			
SCWF 90			
SCWF C0			
SCWF C1			

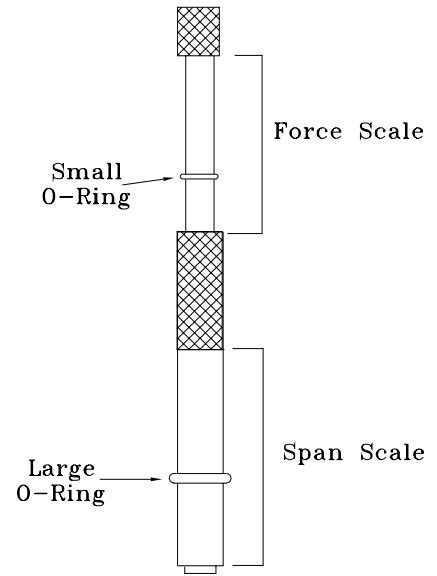

**Figure M-MP-5. Belt tension gauge**

$$\text{deflection} = \text{belt span} / 64$$

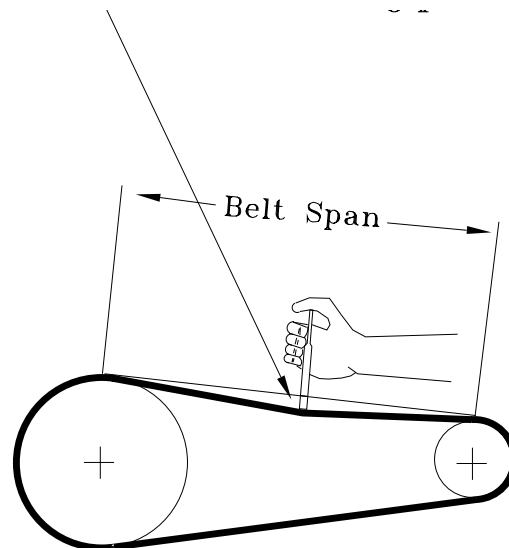

**Figure M-MP-6. Fan belt adjustment**



# Maintenance

## maintenance procedures

### Adjusting Belt Tension

#### NOTICE

**Do not over-tension belts. Excessive belt tension will reduce fan and motor bearing life, accelerate belt wear, and possibly cause shaft failure.**

To adjust belt tension refer to Figure M-MP-6 and perform the following procedure:

1. Loosen bolts A, B, and E on both sides of the sliding motor base. See Figure M-MP-7.
2. Loosen nuts C and D (as required for motor horsepower) to slide the motor on its mounting plate in the proper direction to tension or relieve tension on the belt.
3. Adjust nuts A-D and bolt E. Do not stretch the belts over the sheaves.
4. Retighten all nuts and bolts.
5. Verify tension is adjusted properly.

Recommended belt tension range values are on the unit fan scroll. To access the fan scroll, face the right-hand side of the unit and remove the top left panel. The belt tension label is on the top right-hand corner of the fan scroll. See Figures O-M-8 and O-M-9.

The correct operation tension for a V-belt drive is the lowest tension at which the belt will not slip under the peak load conditions. It may be necessary to increase the tension of some drives to reduce flopping or excessive startup squealing.

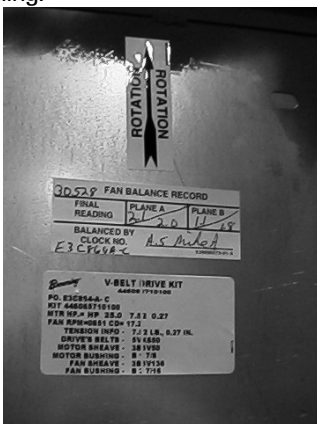

Figure M-MP-8. Location of fan belt label on fan scroll

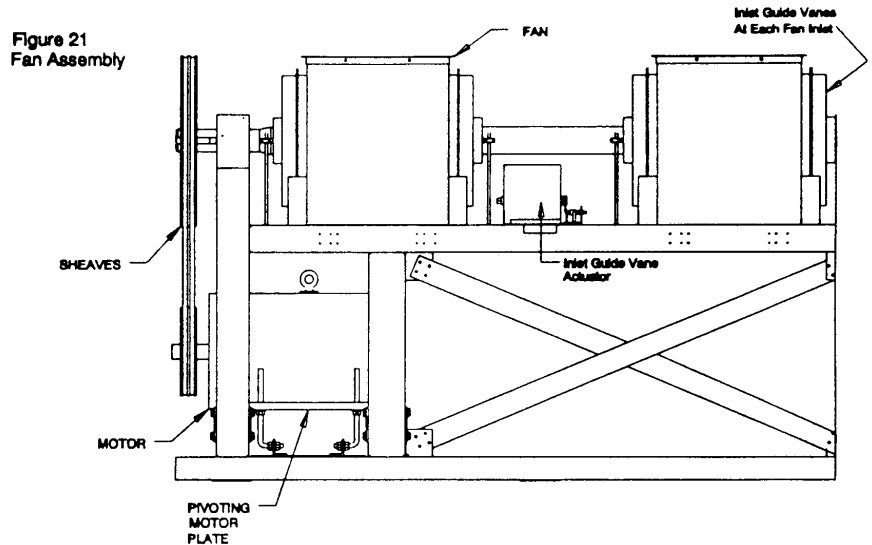

Figure O-M-5. Fan assembly.

Figure 22  
5-20 HP  
Fan Motor  
Adjustment Points

25 HP  
Fan Motor  
Adjustment Points

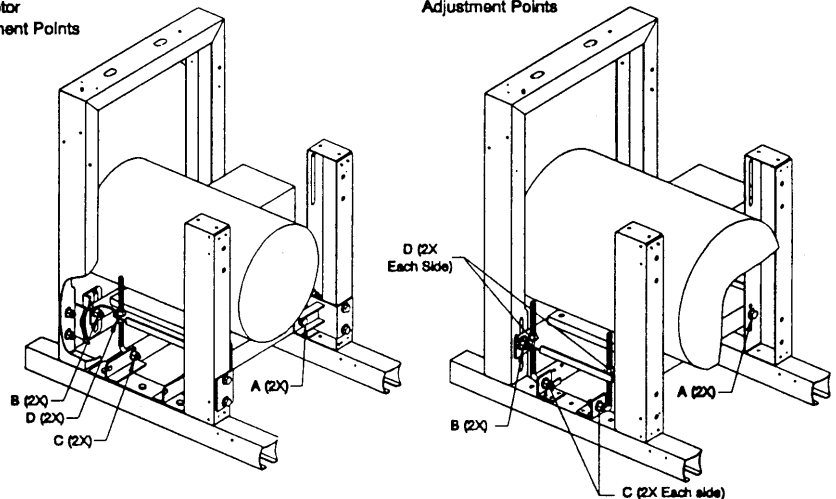

Figure M-MP-7. Belt tensioning with fan adjustment points

## Maintenance

### Refrigerant System

#### Special Note on Refrigerant Emissions

Follow the Trane recommended procedures on operation, maintenance, and service to ensure refrigerant conservation and emission reduction. Also, pay specific attention to the following:

- Whenever removing refrigerant from air conditioning or refrigerating equipment, recover for reuse, recycle, reprocess (reclaim), or properly destroy it.
- Always determine possible refrigerant recycling or reclaiming requirements before beginning recovery. Questions about recovered refrigerants and acceptable refrigerant quality standards are addressed in ARI Standard 700.
- Use approved containment vessels and safety standards. Comply with all applicable transportation standards when shipping refrigerant containers.
- To minimize emissions while recovering refrigerant, use recycling equipment. Always attempt to use methods which will pull the lowest possible system vacuum while recovering and condensing refrigerant into containment.
- Be aware of any new leak test methods which eliminate refrigerant as a trace gas.
- When cleaning system components or parts, do not use CFC11 (R11) or CFC113 (R113). Refrigeration system clean up methods using filters and dryers are recommended. Do not use solvents which have ozone depletion factors. Properly dispose of used materials.
- Take extra care to properly maintain all service equipment directly supporting refrigerant service work such as gauges, hoses, vacuum pumps, and recycling equipment.
- Stay aware of unit enhancements, conversion refrigerants, compatible parts, and vendor components and manufacturer's recommendations that will reduce refrigerant emissions and increase equipment operating efficiencies. Follow specific manufacturer's guidelines for conversion of existing systems.

- To assist in reducing power generation emissions, always attempt to improve equipment performance with improved maintenance and operations that will help conserve energy resources.

#### **WARNING**

##### Confined Space Hazards!

**Do not work in confined spaces where sufficient quantities of refrigerant or other hazardous, toxic, or flammable gas may be leaking. Refrigerant or other gases could displace available oxygen to breathe, causing possible asphyxiation or other serious health risks. Some gases may be flammable and or explosive. Evacuate the area immediately and contact the proper rescue or response authority. Failure to take appropriate precautions or to react properly to a potential hazard could result in death or serious injury.**

#### **WARNING**

##### Hazard of Explosion!

**Use only dry nitrogen with a pressure regulator for pressurizing unit. Do not use acetylene, oxygen or compressed air or mixtures containing them for pressure testing. Do not use mixtures of a hydrogen containing refrigerant and air above atmospheric pressure for pressure testing as they may become flammable and could result in an explosion. Refrigerant, when used as a trace gas should only be mixed with dry nitrogen for pressurizing units. Failure to follow these recommendations could result in death or serious injury or equipment or property-only damage.**

#### **WARNING** **Leak Testing!**

**Do not exceed 200 psig when leak testing system. Failure to follow these instructions could result in an explosion causing death or serious injury.**

In the event of required system repair, leak test the liquid line, evaporator coil, and suction line at pressures dictated by local codes, and using the following guidelines.

1. Charge enough dry nitrogen into the system to raise the pressure to 100 psig.
2. Use a halogen leak detector, halide torch, or soap bubbles to check for leaks. Check interconnecting piping joints, the evaporator coil connections, and all accessory connections.
3. If a leak is detected, release the test pressure, break the connections and reassemble it as a new joint, using proper brazing techniques.
4. If no leak is detected, use nitrogen to increase the test pressure to 150 psig and repeat the leak test. Also, use soap bubbles to check for leaks when nitrogen is added.
5. Retest the system to make sure new connections are solid.
6. If a leak is suspected after the system has been fully charged with refrigerant, use a halogen leak detector, halide torch, or soap bubbles to check for leaks.

#### **Refrigerant Evacuation**

For field evacuation, use a rotary style vacuum pump capable of pulling a vacuum of 400 microns or less.

When connecting the vacuum pump to a refrigeration system, it is important to manifold the pump to both the high and low side of the system. Follow the pump manufacturer's directions.

## Maintenance

### **NOTICE**

#### **Motor Winding Damage!**

Do not use a megohm meter or apply voltage greater than 50 DVC to a compressor motor winding while it is under a deep vacuum. Voltage sparkover may cause damage to the motor windings.

#### **Refrigerant Charging**

##### • **R22 units**

After leak testing and evacuating the system, charge liquid refrigerant into the system through the liquid line valve. After some refrigerant has entered each circuit, charge gaseous refrigerant into the suction line shradar valve with the compressors running.

##### • **R407c**

After leak testing and evacuating the system, charge liquid refrigerant into the system through the liquid line valve.

### **NOTICE**

#### **Compressor Damage!**

Do not operate the compressors without some refrigerant in each circuit. Failure to do so may result in compressor damage.

#### **Special Note on Refrigerant Emissions**

Follow the Trane recommended procedures on operation, maintenance, and service to endure refrigerant conservation and emission reduction. Also, pay specific attention to the following:

- When removing refrigerant from air conditioning or refrigerating equipment recover for reuse, recycling, reprocessing (reclaim), or properly destroy it.
- Always determine possible refrigerant recycling or reclaiming requirements before beginning recovery. Questions about recovered refrigerants and acceptable refrigerant quality standards are addressed in ARI Standard 700.
- Use approved containment vessels and safety standards when shipping

refrigerant containers.

- To minimize emissions while recovering refrigerant, use recycling equipment. Always attempt to use methods that will pull the lowest possible system vacuum while recovering and condensing refrigerant into containment.
- Be aware of any new leak test methods that eliminate refrigerant as a trace gas.
- When cleaning system components or parts, do not use CFC11 (R11) or CFC 113 (R113). Refrigeration system clean-up methods using filters and dryers are recommended. Do not use solvents which have ozone depletion factors. Properly dispose of used materials.
- Take extra care to properly maintain all service equipment directly supporting refrigerant service work such as gauges, hoses, vacuum pumps, and recycling equipment.
- Stay aware of unit enhancements, conversion refrigerants, compatible parts, and manufacturer's recommendations that will reduce refrigerant emissions and increase equipment operating efficiencies. Follow specific manufacturer's guidelines for conversion of existing systems.
- To assist in reducing power generation emissions, always attempt to improve equipment performance with improved maintenance and operations that will help conserve energy resources.

#### **Refrigerant Leak Testing**

It is important to follow all warnings and cautions in this section when leak testing equipment.

### **⚠ WARNING**

#### **Use of Pressure Regulator - Valves - Gauges!**

Always use pressure regulators, valves, and gauges to control drum and line pressures when pressure testing equipment. Failure to follow these instructions could result in an explosion causing death, serious injury, or equipment damage.

### **⚠ WARNING**

#### **Leak Testing!**

Do not exceed 200 psig when leak testing system. Failure to follow these instructions could result in an explosion causing death or serious injury.

In the event of required system repair, leak test the liquid line, evaporator coil, and suction line at pressures dictated by local codes, using the following guidelines.

1. Charge enough refrigerant and dry weight. Use an accurate scale or charging cylinder to determine the exact weight of the refrigerant entering the system. Failure to use either a scale or a charging cylinder can lead to undercharging or overcharging resulting in unreliable operation.

### **⚠ WARNING**

#### **Hazardous Pressures!**

If a heat source is required to raise the tank pressure during removal of refrigerant from cylinders, use only warm water or heat blankets to raise the tank temperature. Do not exceed a temperature of 150°F. Do not under any circumstances apply direct flame to any portion of the cylinder. Failure to follow these safety precautions could result in a violent explosion, which could result in death or serious injury.

### **⚠ CAUTION**

#### **Freezing Temperatures!**

Do not allow liquid refrigerant to contact skin. If it does, treat the injury similar to frostbite. Slowly warm the affected area with lukewarm water and seek immediate medical attention. Direct contact with liquid refrigerant may cause minor or moderate injury.

# Maintenance

## maintenance procedures

To charge the system, complete the following procedure:

1. Charge liquid refrigerant into the liquid line service valve of each compressor circuit. The vacuum will draw some of the required refrigerant into the system. See Figure O-M-9.
2. Complete the charging process by charging gaseous refrigerant into the suction line schrader valve with the unit running. However, make sure that some refrigerant is present in each circuit before starting the compressors. The refrigerant container should be upright so that gaseous refrigerant is drawn off the top.

Note: See Tables M-MP-6 and M-MP-7 for refrigerant charge requirements.

### NOTICE

#### Compressor Damage!

Do not allow liquid refrigerant to enter the suction line. Excessive liquid accumulation in the liquid lines may result in compressor damage.

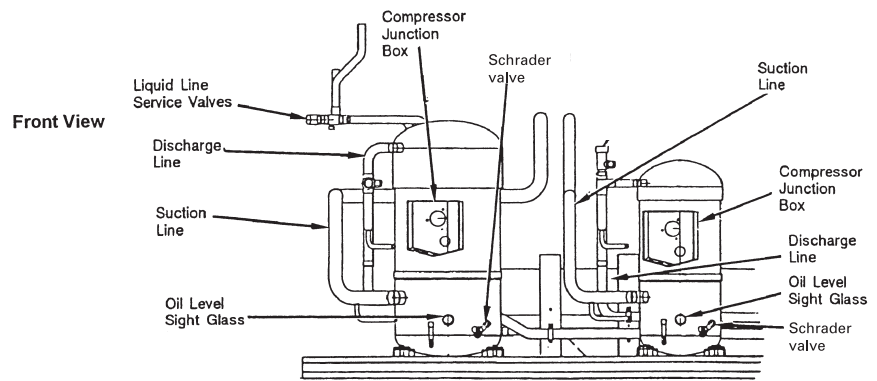

Top View

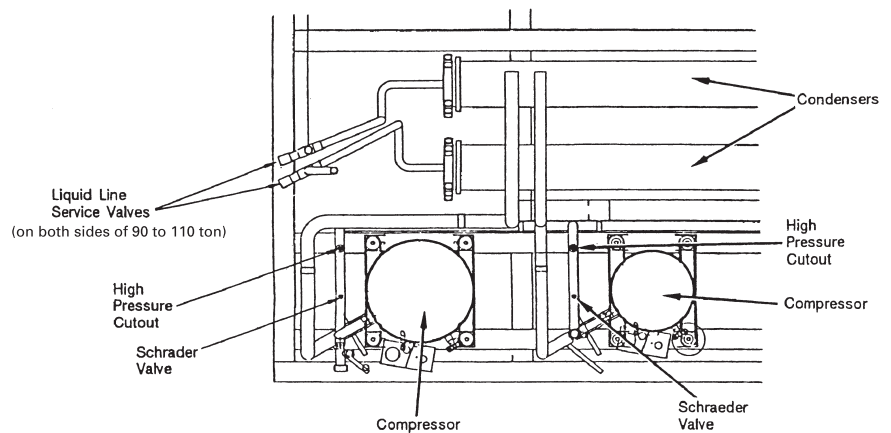

Figure M-MP-10. Typical water-cooled (SXWF) compressor section components

## Maintenance

---

### Inlet Guide Vanes

Perform the following procedure every six months for proper inlet guide vane operation:

1. Spray all parts of guide vane assembly with WD40.
2. Spray all steel parts of guide vane assembly with ZRC.
3. Spray hubs and moving parts with dry silicone lubricant (Mobil Mobilux 2, Shell alvonix 2, or equivalent).

On occasion, the inlet guide vane actuator or inlet guide vanes may need to be removed. For proper adjustment of inlet guide vanes and/or actuator.

---

Note: Perform this procedure monthly if the unit is in a coastal area or corrosive environment.

---

### Coil Fin Cleaning

Keep coils clean to maintain maximum performance. For operation at its highest efficiency, clean the refrigerant coil often during periods of high cooling demand or when dirty conditions prevail. Clean the coil a minimum of once per year to prevent dirt buildup in the coil fins, where it may not be visible.

Remove large debris from the coils and straighten fins before cleaning. Remove filters before cleaning.

Clean refrigerant coils with cold water and detergent, or with one of the commercially available chemical coil cleaners. Rinse coils thoroughly after cleaning.

Economizer and evaporator coils are installed so the evaporator is directly behind the economizer. To clean between the coils, remove the sheet metal block off. Access the block off by removing the corner panels on the unit's left or right rear side.

### **NOTICE** Proper Coil Cleaning Agent!

**Do not clean the refrigerant coil with hot water or steam. The use of hot water or steam as a refrigerant coil-cleaner agent may cause high pressure inside the coil tubing and subsequent damage to the coil.**

**Do not use acidic chemical coil cleaners. Also, do not use alkaline chemical coil cleaners with a pH value greater than 8.5 (after mixing) without using an aluminum corrosion inhibitor in the cleaning solution. Use of the chemical may result in equipment damage.**

### **⚠️ WARNING** Hazardous Chemicals!

**Coil cleaning agents can be either acidic or highly alkaline. Handle chemical carefully. Proper handling should include goggles or face shield, chemical resistant gloves, boots, apron or suit as required. For personal safety refer to the cleaning agent manufacturer's Materials Safety Data Sheet and follow all recommended safe handling practices. Failure to follow all safety instructions could result in death or serious injury.**

If the refrigerant coil is installed back to back with the waterside economizer coil, use a cleaner that is acceptable for cleaning both types of coils.

### **⚠️ WARNING** Hazardous Voltage w/Capacitors!

**Disconnect all electric power, including remote disconnects before servicing. Follow proper lockout/tagout procedures to ensure the power cannot be inadvertently energized. For variable frequency drives or other energy storing components provided by Trane or others, refer to the appropriate manufacturer's literature for allowable waiting periods for discharge of capacitors. Verify with an appropriate voltmeter that all capacitors have discharged. Failure to disconnect power and discharge capacitors before servicing could result in death or serious injury.**

**Note: For additional information regarding the safe discharge of capacitors, see PROD-SVB06A-EN or PROD-SVB06A-FR.**

## Maintenance

### Inspecting and Cleaning Coils

Coils become externally fouled as a result of normal operation. Coil surface dirt reduces heat transfer ability and can cause comfort problems, increased airflow resistance and thus increased operating energy costs.

Inspect coils at least every six months or more frequently as dictated by operating experience. Cleaning frequently is dependent upon system operating hours, filter maintenance, efficiency, and dirt load. Following is the suggested method for cleaning steam and hot water coils.

#### Steam and Hot Water Coils

1. Disconnect all electrical power to the unit.
2. Wear the appropriate personal protective equipment (PPE).
3. Access both sides of the coil section.
4. Use a soft brush to remove loose debris from both sides of the coil.
5. Use a steam cleaning machine, starting from the top of the coil and working downward. Clean the leaving air side of the coil first, then the entering air side. Use a block-off to prevent steam from blowing through the coil and into a dry section of the unit.
6. Repeat step 5 as necessary. Confirm that the drain line is open following completion of the cleaning process.
7. Allow the unit to dry thoroughly before putting the system back into service.
8. Straighten any coil fins that may be damaged with a fin rake.
9. Replace all panels and parts and restore electrical power to the unit.
10. Ensure that contaminated material does not contact other areas of the equipment or building. Properly dispose of all contaminated materials and cleaning solutions.

#### Refrigerant Coils

1. Disconnect all electrical power to the unit.
2. Wear the appropriate personal protective equipment (PPE).
3. Access to the coil section of the unit (both sides).
4. Use a soft brush to remove loose debris from both sides of the coil.

5. Mix a high quality coil cleaning detergent with water according to the manufacturer's instructions. If the detergent is strongly alkaline after mixing (pH 8.5 or higher), it must contain an inhibitor. Carefully follow the cleaning solution manufacturer's instructions regarding product use.
6. Place the mixed solution in a garden pump-up sprayer or high pressure sprayer. If using a high pressure sprayer note the following:
  - Maintain a minimum nozzle spray angle of 15°
  - Spray perpendicular to the coil face
  - Protect other areas of the equipment and internal controls from contact with moisture or the cleaning solution
  - Keep the nozzle at least six inches from the coil
  - Do not exceed 600 psig

#### Draining the Waterside Economizer Coil

### NOTICE Coil Freezeup!

**Properly drain and vent coils when not in use. Trane recommends glycol protection in all possible freezing applications. Use a glycol approved for use with commercial cooling and heating systems and copper tube coils. Failure to do so may result in equipment damage.**

Drain plugs are in the piping below each coil's supply and return header. Use these plugs to drain the coil and piping. When draining the coil, open the vents at the top of the supply and return headers. Also, a drain plug is at the bottom of the inlet condenser manifold and in the outlet pipe near the unit's left side. Remove these plugs to drain the condensers. Be sure to open the vent plugs at the top of the condenser inlet and outlet manifold. See Figure O-M-9.

When refilling the condenser/waterside economizer coil system with water, provide adequate water treatment to prevent the formation of scale or corrosion.

#### Cleaning the Condenser

### NOTICE Proper Water Treatment!

**The use of untreated or improperly treated water in a CenTraVac may result in scaling, erosion, corrosion, algae or slime. It is recommended that the services of a qualified water treatment specialist be engaged to determine what water treatment, if any, is required. Trane assumes no responsibility for equipment failures which result from untreated or improperly treated water, or saline or brackish water.**

Condensing water contains minerals that collect on the condenser tube walls. Cooling towers also collect dust and foreign materials that deposit in the condenser tube. The formation of scale or sludge in the condenser is indicated by a decreased water flow, low temperature difference between inlet and outlet water, and abnormally high condensing temperatures. To maintain maximum condenser efficiency, the condenser must remain free of built-up scale and sludge. Clean the condenser either mechanically or chemically.

#### Mechanical Cleaning of Condenser and Economizer Coils

1. Turn off the condenser supply water. Remove drain plugs discussed in the "Draining the Coil" section on page 91.
2. Remove the condenser head to expose the condenser tubes.
3. Rotate a round brush through the tubes to loosen contaminant.
4. Flush tubes with water to push the sludge out through the drain opening in the bottom of the supply header and the return pipe.
5. To clean the economizer tubes, remove the cast iron header plates at both sides of the coil between the inlet and outlet headers (four-row coils only; two-row coils do not have cover plates at right end). Rotate round brush through tubes from left end to loosen contaminants. Flush tubes with water.

## maintenance procedures

# Maintenance

6. Replace condenser end plates and clamps. The end plates must be centered when tightening the clamp.
7. Replace coil headers with gaskets and torque bolts to 50 ft.-lb.
8. Replace drain and vent plugs.

### Chemical Cleaning of Condenser and Economizer Coil

Chemical cleaning removes scale deposits built up by minerals in the water. For a suitable chemical solution, consult a water treatment specialist. The condenser water circuit is composed of copper, steel, and cast iron.

The chemical supply house should approve or provide all materials used in the external circulating system, along with the quantity of cleaning material, duration of cleaning time, and safety precautions necessary for handling the cleaning agent.

### Piping Components

#### Water Valves

Water valves have a stern packing nut. If there is evidence of water leakage at the valve stem, proceed as follows:

### WARNING

#### Hazardous Voltage w/Capacitors!

**Disconnect all electric power, including remote disconnects before servicing. Follow proper lockout/tagout procedures to ensure the power cannot be inadvertently energized. For variable frequency drives or other energy storing components provided by Trane or others, refer to the appropriate manufacturer's literature for allowable waiting periods for discharge of capacitors. Verify with an appropriate voltmeter that all capacitors have discharged. Failure to disconnect power and discharge capacitors before servicing could result in death or serious injury.**

**Note: For additional information regarding the safe discharge of capacitors, see PROD-SVB06A-EN or PROD-SVB06A-FR.**

1. Remove actuator motor from support plate.
2. Remove shaft coupling.
3. Torque the packing nut to 10-ft.-lbs. of torque.
4. Replace shaft coupling.
5. Replace actuator motor.

### Flow Switch Maintenance

Flow switches have a magnet on the vane assembly that attracts ferrous particulate may build up on the magnet to the point that the vane will wedge and not operate properly.

When the flow switch does not operate, remove and replace it or disassemble and clean it.

#### Cleaning the Flow Switch

If ferrous particulate contaminates tower water, the ferrous particles may cling to the magnet on the switch paddle assembly. Build up of the ferrous particles may cause the paddle to stick and not function properly.

To avoid this problem, remove the switch and clean each time you clean the condensers, or clean as needed to keep the switch operational.

To clean the paddle assembly, remove it following the procedure below:

1. Remove the switch from the unit.
2. The paddle assembly and wire retainer clip holds the paddle assembly in the switch body.
3. Remove the wire retainer clip by reaching down past the paddle with a pair of slim nosed pliers and gripping the end of the wire. Pull up on the wire, clip, and remove it.
4. After removing the wire clip, use the pliers to pull the paddle assembly out of the switch barrel. Clamp the pliers onto the end of the paddle and remove the paddle assembly. It will slide straight out.
5. Clean the ferrous particulate from the magnet using a rag or tack cloth. The particulate is attracted to the magnet, so it is necessary to pull it off. It will not easily wipe off.
6. After cleaning the magnet, replace the paddle assembly into the switch body's barrel. However, it is important to position the paddle perpendicular to the arrow on the switch's side and place the paddle's flat side facing the opposite

direction or the arrow. Push the paddle assembly in until it hits the barrel cavity bottom.

7. Place the spring clip into the switch barrel and push it down with a small, flat blade screwdriver until the spring clip engages the groove in the switch barrel.
8. When replacing the paddle assembly, check the operation by pushing on the paddle's flat side. The paddle should swing freely in the direction of the arrow. This action confirms that the paddle assembly is properly installed.
9. Replace the switch into the unit piping using a good pipe thread sealer. Tighten the switch so that its final position has the arrow parallel to the water pipe and pointing toward the left end of the unit (arrow is pointing in the direction of the water flow).

## Maintenance

### Maintenance Periodic Checklists

#### Monthly Checklist

The following check list provides the recommended maintenance schedule to keep the commercial self-contained equipment running efficiently.

#### **⚠️ WARNING**

#### **Hazardous Voltage w/Capacitors!**

**Disconnect all electric power, including remote disconnects before servicing. Follow proper lockout/tagout procedures to ensure the power cannot be inadvertently energized. For variable frequency drives or other energy storing components provided by Trane or others, refer to the appropriate manufacturer's literature for allowable waiting periods for discharge of capacitors. Verify with an appropriate voltmeter that all capacitors have discharged. Failure to disconnect power and discharge capacitors before servicing could result in death or serious injury.**

**Note: For additional information regarding the safe discharge of capacitors, see PROD-SVB06A-EN or PROD-SVB06A-FR.**

1. Inspect unit air filters. Clean or replace if airflow is blocked or if filters are dirty.
2. Inspect coils for excess moisture or icing. Icing on the coils may indicate low airflow supply, restricted airflow from dirty fins, evaporator frost protection sensor problems, or a shortage of refrigerant flowing through the coil.
3. Check that condensate from the evaporator and economizer coils flows freely through the condensate piping, traps, drain pan, and drainage holes.

- Remove algae and or any airflow obstructions.
4. Check the condition and tension of fan belts. Adjust tension if belts are floppy or squeal continually. Replace worn or fraying belts in matched sets.

Note: Check belt tension and adjust it at least twice daily the first days of new belt operation. Belt tension will rapidly decrease until the belts are run in.

5. Check the liquid line sight glasses during operation. Bubbles in the sight glasses indicate a possible shortage of refrigerant or an obstruction in the liquid lines, e.g. dirty liquid line filter driers.
6. Inspect filter driers for leaks, flow obstructions, or temperature drop across the filter drier. A noticeable temperature differential, e.g. 5°F in the liquid line may indicate an obstruction. Replace the filter drier if it appears clogged.
7. Inspect the optional waterside economizer coil. Clean the coil to prevent airflow restrictions through the fins.
8. Check and record operating pressures.

#### **Semi-Annual Maintenance**

1. Verify the fan motor is properly lubricated. Follow lubrication recommendations on the motor tag or nameplate. Contact the motor manufacturer for more information.
2. Lubricate fan bearings. For best results, lubricate bearings during unit operation. Refer to the "Fan Bearings" section on page 84.
3. With power disconnected, manually rotate the fan wheel to check for obstructions in the housing or interference with fan blades or inlet guide vane option. Remove obstructions and debris. Center the fan wheel if necessary.

4. Check the fan assembly sheave alignment. Tighten set screws to their proper torques.
5. Check water valves for leakage at valve stem packing nut.
6. Inspect the inlet vane assembly and perform maintenance procedures in the IGV maintenance section.

Note: Perform this procedure monthly if the unit is in a coastal or corrosive environment.

#### **Annual Maintenance**

Check and tighten all set screws, bolts, locking collars and sheaves.

1. Inspect, clean, and tighten all electrical connections.
2. Visually inspect the entire unit casing for chips or corrosion. Remove rust or corrosion and repaint surfaces.
3. Visually check for leaks in refrigerant piping.
4. Inspect fan, motor, and control contacts. Replace badly worn or eroded contacts.
5. Inspect the thermal expansion valve sensing bulbs for cleanliness, good contact with the suction line, and adequate insulation from ambient air.
6. Verify the superheat setting is 12 -17°F at the compressor.

When checking operating pressures and conditions, establish the following nominal conditions for consistent measurements.

1. Leaving air temperature greater than 60°F
2. Entering air temperature is 80 - 90°F
3. Entering water temperature greater than 65°F
4. Inlet guide vanes at least halfway open
5. Compressors running at full load
6. Drain the condensing water system and inspect it thoroughly for fouling, clean condensers if necessary.



# Maintenance

# troubleshooting

## System Checks

### **⚠️ WARNING**

#### **Live Electrical Components!**

During installation, testing, servicing and troubleshooting of this product, it may be necessary to work with live electrical components. Have a qualified licensed electrician or other individual who has been properly trained in handling live electrical components perform these tasks. Failure to follow all electrical safety precautions when exposed to live electrical components could result in death or serious injury.

Before proceeding with technical trouble charts or controls checkout, complete the following system analysis:

1. Measure actual supply voltage at the compressor and an motor terminals with the unit running. Voltage must be within the range listed on the motor nameplate. Phase imbalance must be less than 2.0%.
2. Check all wiring and connections to be sure that they are intact, secure and properly routed. The as wired system diagrams are provided in the unit control panel.
3. Check that all fuses are installed and properly sized.

4. Inspect air filters and coils to be sure that airflow to the unit is not restricted.
5. Check the zone thermostat settings.
6. Ensure that the fan is rotating in the proper direction. If phasing is wrong at the main power terminal block, the fan and compressors will not run correctly.
7. Inspect ductwork and duct connections for tightness.

#### **Operating Procedures**

Install pressure gauges on the discharge and suction line access valves. When the unit has stabilized (after operating approximately 15 minutes at full load), record suction and discharge pressures. System malfunctions such as low airflow, line restrictions, incorrect refrigerant charge, malfunctioning of expansion valves, damaged compressors, etc. will result in pressure variations which are outside the normal range.

---

Note: If phasing at the main incoming power terminal is incorrect, switch two of the three incoming power leads. If a compressor has been replaced and the phase is changed at the compressor, it will run backwards and discharge pressure will be very low. To resolve incorrect compressor wire phasing, change phasing at the compressor.

---

It is important that pressures be measured under stable and constant conditions in order for the readings to be useful.

#### **Voltage Imbalance**

Voltage imbalance on three-phase systems can cause motor overheating and premature failure. Maximum allowable imbalance is 2.0%, and the readings used to determine it must be measured at the compressor terminals.

Voltage imbalance is defined as 100 times the sum of the division of the three voltages from the average voltage. If, for example, the three measured voltages are 221, 230, 227, the average is:

$$\frac{(221+230+227)}{3} = 226 \text{ volts}$$

Therefore, the percentage of voltage imbalance is:

$$\frac{100*(226-221)}{226} = 2.2\%$$

In this example, 2.2% imbalance of more than 2.0% exists, be sure to check the voltage at the unit disconnect and terminal block switch. If an imbalance at the unit disconnect switch does not exceed 2.0%, the imbalance is caused by faulty wiring within the unit. Be sure to conduct a thorough inspection of the unit electrical wiring connections to locate the fault, and make any repairs necessary.

#### **Common Unit Problems and Solutions**

Problem	Possible Cause	Remedy
Drain pan is overflowing	Plugged drain line Unit not level	Clean drain line Level unit
Standing water in drain pan	Unit not level Plugged drain line	Level Unit Clean drain line
Wet interior insulation	Coil face velocity too high Improper trap design Drain pan leaks/overflowing Condensation on surfaces	Reduce fan speed Design trap per unit installation instructions Repair Leaks Insulate surfaces
Excess dirt in unit	Missing filters Filter bypass	Replace filters Reduce filter bypass
Microbial growth (mold)	Standing water in drain pan Moisture problems	See "Standing water in drain pan" above See "Wet interior insulation" above



# Maintenance

# diagnostics

## Diagnostics

Refer to the *IntelliPak Self-Contained Programming Guide, PKG-SVP01B-EN*, for specific unit programming and troubleshooting information. In particular, reference the "Service Mode Menu" and "Diagnostic Menu" sections in the programming guide. Refer to the following text for general diagnostic and troubleshooting procedures. Common diagnostics and troubleshooting procedures follow below.

### A

#### Auto Reset S/A Static Pressure Limit

Problem: The supply air static pressure went too high.

Reason for Diagnostic: The S/A static pressure exceeded the S/A static pressure limit setpoint for at least one second continuously.

UCM Reaction: A "supply air pressure shutdown" signal is sent to the following functions:

- Compressor staging control,
- Economizer actuator control,
- Heat operation,
- Supply fan control,
- IGV/VFD control,
- Exhaust fan control,
- Exhaust actuator control

Reset Required: (PAR) An automatic reset occurs after the IGV close. The supply fan is not allowed to restart for 15 seconds after the diagnostic occurs. An auto reset will also occur if the unit cycles out of occupied mode and back.

### C

#### CO<sub>2</sub> Sensor Failure

Problem: The VCM CO<sub>2</sub> sensor input signal is out of range.

Check: Check field/unit wiring between sensor and VCM.

Reason for Diagnostic: The unit is reading a signal that is out of range for the CO<sub>2</sub> sensor transducer input.

UCM Reaction: The CO<sub>2</sub> reset function disables.

Reset Required: (PAR) An automatic reset occurs after the CO<sub>2</sub> sensor transducer input receives a signal that is within range for ten continuous seconds.

#### Compressor Contactor Fail - Circuit 1, 2, 3, or 4

Problem: The compressor contactor for Ckt. 1, 2, 3, or 4 has malfunctioned.

Reason for Diagnostic: The circuit compressor proving input is detected closed continuously for more than three seconds while neither compressor output on that circuit closes.

UCM Reaction: A "lockout ckt #1, 2, 3, or 4" request is issued to the compressor staging control function.

Reset Required: (PMR) A manual reset is required after the diagnostic is set. It can be reset by the HI or Tracer Summit.

#### Compressor Trip - Ckt 1, 2, 3, or 4

Problem: The compressor ckt #1, 2, 3, or 4 has tripped.

Reason for Diagnostic: The ckt #1, 2, 3, or 4 compressor proving input is detected open continuously for more than 3 seconds when either or both compressor outputs on that circuit energize (as described in the compressor protection function).

Reason for Diagnostic: The circuit compressor proving input is detected open continuously for more than 3 seconds when either or both compressor outputs on that circuit energize (as described in the compressor protection function).

UCM Reaction: A "lockout ckt #1, 2, 3, or 4" request is issued to the compressor staging control function.

Reset Required: (PMR) A manual reset is required after this diagnostic occurs. The diagnostic can be reset by the unit mounted HI module or Tracer Summit.

#### Condenser Temp Sensor Failure - Circuit 1, 2, 3, or 4

Problem: The saturated condenser temperature input is out of range for circuit #1, 2, 3, or 4.

Check: Sensor resistance should be between 830 ohms (200°F) and 345.7 ohms (-40°F). If so, check field/unit wiring between sensor and MCM/SCM.

Reason for Diagnostic: The unit is reading a signal that is out of range for the circuit #1, 2, 3, or 4 saturated condenser temperature sensor. (temp < -55°F or temp > 209°F).

UCM Reaction: A "Lockout Ckt # 1, 2, 3, or 4" request is issued to the compressor staging control function.

Reset Required: (PAR) An automatic reset occurs after the circuit 1, 2, 3, or 4 condenser temp input returns to its allowable range within 10 seconds.

### D

#### Dirty Filter

Problem: There is a dirty filter.

Reason for Diagnostic: The filter switch input on the RTM is closed for more than 60 seconds continuously.

UCM Reaction: An information only diagnostic is set.

Reset Required: (INFO) An automatic reset occurs after the dirty filter input reopens for 60 continuous seconds.

### E

#### ECEM Communications Failure

Problem: The RTM has lost communication with the ECCEM.

Check: Field/unit wiring between RTM and ECCEM module.

Reason for Diagnostic: The RTM has lost communication with the ECCEM.  
UCM Reaction: If the unit has the comparative enthalpy option, the economizer enable r.e. enthalpy function will revert to level 2 enthalpy comparison.

# Maintenance

# diagnostics

Reset Required: (PAR) An automatic reset occurs after communication has been restored.

### Emergency Stop

Problem: The emergency stop input is open.

Reason for Diagnostic: An open circuit has occurred on the emergency stop input caused either by a high duct temp t-stat trip, or the opening of field-provided contacts, switch, etc.

UCM Reaction: Off or close requests are issued as appropriate to the following functions;

- Compressor staging/chilled water cooling control
- Heat operation
- Supply fan control and proof of operation
- Exhaust fan control and proof of operation.
- Exhaust actuator control
- Outside air damper control
- On VAV units, IG/VFD control

Reset Required: (PMR) A manual reset is required after the emergency stop input recloses. The diagnostic can be reset by the HI.

### Entering Cond Water Temp Sensor Fail

Problem:

Activation Conditions: temperature < -50°F or temperature > 209°F, and unit configured for water cooled condenser

- Time to React: 10 sec < T < 20 sec
- DiagnosticText (Human Interface Display) "ENT COND WATER TEMP SENSOR FAIL"
- Actions to be Initiated: A "Lockout All Ckts " request is issued to the "Compressor Staging Function"
- Reset: An automatic reset occurs after the entering condenser water temperature input returns to within range continuously for 15 seconds.

### Entering Water Temp Sensor Fail

- Data used (module, packet, byte, bit): WSM, 01,18,05
- Activation Conditions: temperature < -50°F or temperature > 209°F, and unit

- configured with water cooled condenser and/or economizer
- Time to React: 10 sec < T < 20 sec
- DiagnosticText (Human Interface Display) "ENTERING WATER TEMP SENSOR FAIL"
- Actions to be Initiated: A "Disable Water Side Economizer" request is issued to "Water Side Economizer Temperature Enable Function"
- Reset: An automatic reset occurs after the Entering WaterTemp. input returns to within range continuously for 10 seconds.

### Evap Temp Sensor Failure - Circuit 1, 2, 3, or 4

Problem: The evaporator temperature sensor (ckt #1, 2, 3, or 4) is out of range.

Check: Sensor resistance should be between 830 ohms (200°F) and 345.7Kohms (-40°F). If so, check field/unit wiring between sensor and MCM/SCM.

Reason for Diagnostic: The unit is reading a signal that is out of range for the circuit #1 evaporator temperature sensor input (temp < -55°F or temp > 209°F).

UCM Reaction: The coil frost protection function for the refrigeration circuit (#1, 2, 3, or 4) only is disabled.

Reset Required: (PAR) An automatic reset occurs after the #1, 2, 3, or 4 evap temp input returns to its allowable range for 10 seconds.

## G

### GBAS 0-5 VDC Module Comm Failure

Problem: The RTM has lost communication with the GBAS module.

Check: Field/unit wiring between RTM and GBAS.

Reason for Diagnostic: The RTM has lost communication with the GBAS module.

UCM Reaction: The UCM will initiate the following actions;

- If the demand limit input was closed prior to the communications loss, then the demand limit commands issued to the heat operation function (if applicable) and the compressor staging/

chilled water cooling function will be cancelled.

- If any of the GBAS setpoint control parameters are the HI-selected setpoint sources, then those setpoints will revert to the default HI setpoints.
- Any active GBAS output control parameters will be ignored.
- A failsafe function in the GBAS module will cause all GBAS outputs to be zeroed and deenergized.

Reset Required: (PAR) An automatic reset occurs after communication has been restored.

## H

### Heat Failure

Problem: The heat has failed. (Electric heat unit) Typically, this is because the electric heat section became too hot.

Reason for Diagnostic: The heat fail input on the heat module was closed:

- for more than 80 seconds,
- for ten consecutive occurrences (each lasting five seconds or more) within a 210 second period.

UCM Reaction: An information only diagnostic is set.

Reset Required: (INFO) An automatic reset occurs after the heat fail input remains open for 210 seconds continuously.

### Heat Module Auxilliary Temperature Sensor Fail

Problem: The heat mod aux temp sensor input is out of range.

Check: Sensor resistance should be between 830 ohms (200°F) and 345.7 ohms (-40°F). If so, check field/unit wiring between sensor and heat module.

Reason for Diagnostic: At least one enabled unit function has the heat module auxilliary temperature input designated as its sensor, and the unit is reading a signal that is out of range for this input (temp < -55°F or temp > 209°F).

UCM Reaction: The functions that



# Maintenance

# diagnostics

designated the heat module auxillary temperature input as their input are disabled.

Reset Required: (PAR) An automatic reset occurs after the heat module auxillary temperature input returns to its allowable range for 10 seconds.

### Heat Module Comm Failure

Problem: The RTM has lost communication with the heat module.

Check: Check field/unit wiring between RTM and heat module.

Reason for Diagnostic: The RTM has lost communication with the heat module.

UCM Reaction: An "all heat off" request is sent to the heat operation function.

If the unit has staged gas or electric heat, all heat module outputs will be zeroed and deenergized.

If the unit has hydronic heat or chilled water installed, the unit will turn off the supply fan and close the outside air damper upon the occurrence of a heat module comm failure. A failsafe function in the heat module will cause all water valves to be set to 100% to provide full water flow. Unless used for switching purposes (air handlers with chilled water and mod gas, or chilled water and hydronic heat) all binary outputs will be deenergized.

Reset Required: (PAR) An automatic reset occurs after communication has been restored.

## L

### Low Air Temp Limit Trip

Problem: The low air temp limit has tripped. (Units with steam or hot water heating, or air handlers with chilled water cooling)

Reason for Diagnostic: A low air temp limit trip is detected continuously for more than one second. This can occur if the hydronic heat low air temp limit input closes for > 1 second, or if the chilled water low air temp limit trip input opens

for > 1 second. On units with both hydronic heat and chilled water, both low air temp limit inputs are active, and the unit will respond in the same manner regardless of which input is used.

UCM Reaction: The UCM will initiate the following actions;

- An "open all water valves" request is issued to the heat module function, causing any steam, hot water, or chilled water valves on the unit to open.
- An "all heat off" request is issued to the heat control function.
- A "fan off" request is sent to the supply fan control function.
- A "close damper" request is sent to the economizer actuator control function.

Reset Required: (PMR) A manual reset is required after the low air temp limit trip condition clears. The diagnostic can be reset at the unit mounted human interface, by Tracer Summit, or by cycling power to the RTM.

### Low Pressure Control Open - Circuit 1, 2, 3, or 4

Problem: The Low Pressure Control (LPC) for Ckt #1, 2, 3, or 4 is open.

Check: State of refrigerant charge for ckt #1, 2, 3, or 4.

Reason for Diagnostic: The Ckt # 1 LPC input is detected open as described in the compressor protection function.

UCM Reaction: A "Lockout Ckt # 1, 2, 3, or 4" request is issued to the compressor staging control function.

Reset Required: (PMR) A manual reset is required anytime after the diagnostic is set. The diagnostic can be reset by the human interface, Tracer Summit, or by cycling power to the RTM.

## M

### Manual Reset SA Static Press Limit

Problem: The supply air static pressure went too high for the third consecutive time.

Reason for Diagnostic: The auto reset

supply air static pressure limit diagnostic has occurred for the third time while the unit is operating in occupied mode.

UCM Reaction: A "supply air pressure shutdown" signal is sent to the following functions;

- Compressor staging control,
- Economizer actuator control,
- Heat operation,
- Supply fan control,
- IGV/VFD control,
- Exhaust fan control
- Exhaust actuator control

Reset Required: (PMR) A manual reset is required and can be accomplished at the HI, Tracer Summit, or by cycling power to the RTM.

### MCM Communications Failure

Problem: The RTM has lost communication with the MCM.

Check: Check field/unit wiring between RTM and MCM.

Reason for Diagnostic: The RTM has lost communications with the MCM.

UCM Reaction: A "Lockout" request is sent to the compressor staging control function. And a failsafe function in the MCM will cause all MCM outputs to be zeroed and deenergized.

Reset Required: (PAR) An automatic reset occurs after communication has been restored.

### Mode Input Failure

Problem: The RTM mode input is out of range.

Check: Sensor resistance should be between 1 ohm and 40 ohms. If so, check field/unit wiring between sensor and RTM.

Reason for Diagnostic: The mode input signal on the RTM is out of range (resistance < 1 ohm or resistance > 40 ohms).

UCM Reaction: The system mode reverts to the default (HI set) system mode.

Reset Required: (INFO) An automatic reset

# Maintenance

# diagnostics

occurs after the mode input returns to its allowable range for 10 seconds.

## N

### **NSB Panel Zone Temperature Sensor Failure**

**Problem:** The NSB panel's zone temp sensor input is out of range. (This input is at the NSB panel, not on the unit itself).

**Check:** If have an external sensor connected to the NSB panel zone sensor input, then the internal NSB panel zone sensor should be disabled. Verify sensor resistance. If in valid range, check wiring between the sensor and NSB panel.

### **NSB Panel Comm Failure**

**Problem:** The RTM has lost communications with the night setback panel (programmable zone sensor).

**Check:** Field/unit wiring between RTM and NSB Panel.

**Reason for Diagnostic:** The RTM has lost communication with the NSB panel.

**UCM Reaction:** The unit reverts to the next lower priority mode switching source (typically the HI default mode). If the NSB panel zone sensor is the designated sensor source for any functions, those functions are disabled.

**Reset Required:** (PAR) An automatic reset occurs after communication has been restored.

## O

### **O/A Humidity Sensor Failure**

**Problem:** The outside air humidity sensor data is out of range.

**Check:** Check field/unit wiring between the sensor and RTM.

**Reason for Diagnostic:** The unit is reading a signal that is out of range for the outside air humidity sensor (humidity < 5% or humidity > 100%).

**UCM Reaction:** The economizer enable enthalpy function reverts to dry-bulb

temperature changeover ("Level 1") control.

**Reset Required:** (PAR) An automatic reset occurs after the OA humidity input returns to its allowable range for 10 seconds.

### **O/A Temp. Sensor Failure**

**Problem:** The outside air temperature sensor input is out of range.

**Check:** Sensor resistance should be between 830 ohms (200°F) and 345.7 ohms (-40°F). If so, check field/unit wiring between sensor and RTM.

**Reason for Diagnostic:** The unit is reading a signal that is out of range for the outside air temperature input on the RTM (temp. < -55°F or temp > 209°F).

**UCM Reaction:** These unit functions occur:

- low ambient compressor lockout disables
- O/A damper drives to minimum position
- on VAV units with S/A temp. reset type selected as O/A temp. reset, the reset type reverts to "none" for the duration of the failure

**Reset Required:** (PAR) an automatic reset occurs after the O/A temperature input returns to its allowable range. To prevent rapid cycling of the diagnostic, there is a 10 second delay before the automatic reset.

### **Occupied Zone Heat Setpoint Failure**

**Problem:** The occupied zone heat setpoint input is out of range.

**Reason for Diagnostic:** The input designated as occupied zone heating setpoint source is out of range for the outside air temperature input on the RTM (temp. < 45°F or temp > 94°F).

**UCM Reaction:** The active occupied zone heating setpoint reverts to the default value.

**Reset Required:** (PAR) an automatic reset occurs after the occupied zone heating setpoint input returns to its allowable

range for 10 continuous seconds, or after a different occupied zone heating setpoint selection source is user-defined.

## R

### **Return Air Humidity Sensor Failure**

**Problem:** On units with both airside economizer and comparative enthalpy installed, the return air humidity sensor input is out of range.

**Check:** Check field/unit wiring between the sensor and ECEM.

**Reason for Diagnostic:** The unit is reading a signal that is out of range for the return air humidity sensor (humidity < 5% or humidity > 100%).

**UCM Reaction:** The economizer enable r.e. enthalpy function reverts to reference enthalpy changeover ("Level 2") control.

**Reset Required:** (PMR) An automatic reset occurs after the RA humidity input returns to its allowable range continuously for 10 seconds.

### **Return Air Temp Sensor Failure**

**Problem:** On units with the comparative enthalpy option, the return air temperature sensor input is out of range.

**Check:** Sensor resistance should be between 830 ohms (200°F) and 345.7 ohms (-40°F). If so, check field/unit wiring between the sensor and ECEM.

**Reason for Diagnostic:** The unit is reading a signal that is out of range for the return air humidity sensor (temp < -55°F or temp > 209°F).

**UCM Reaction:** The economizer enable r.e. enthalpy function reverts to reference enthalpy changeover ("Level 2") control.

**Reset Required:** (PAR) An automatic reset occurs after the RA temp input returns to its allowable range continuously for 10 seconds.



## Maintenance

## diagnostics

### RTM Aux. Temp. Sensor Failure

Problem: The RTM auxiliary temperature sensor data is out of range.

Check: Sensor resistance should be between 830 ohms (200°F) and 345.7 ohms (-40°F). If so, check field/unit wiring between sensor and RTM.

Reason for Diagnostic: At least one enabled unit function has the RTM auxiliary temperature input designated as its sensor, and the unit is reading a signal that is out of range for this input (temp. < -55°F or temp > 209°F).

UCM Reaction: The functions with the RTM auxiliary temperature input designated as their sensor are disabled.

Reset Required: (PAR) an automatic reset occurs after the designated zone temperature signal returns to its allowable range. To prevent rapid cycling of the diagnostic, there is a 10 second delay before the automatic reset.

### RTM Data Storage Error

Problem: There was a data transmission error.

Check: This can be caused by an intermittent power loss. Turn the unit off for 1-2 minutes, then back on again. If diagnostic persists, then the RTM may need to be replaced.

Reason for Diagnostic: An error occurred while the RTM was writing data to its internal non-volatile memory (EEPROM).

UCM Reaction: An information only diagnostic will be displayed at the human interface.

Reset Required: (INFO) A manual reset may be made at the human interface, at Tracer Summit, or by cycling power to the RTM.

### RTM Zone Sensor Failure

Problem: The RTM zone temperature sensor input is out of range.

Check: Sensor resistance should be between 830 ohms (200°F) and 345.7

ohms (-40°F). If so, check field/unit wiring between sensor and RTM.

Reason for Diagnostic: At least one enabled unit function has the RTM zone temperature input designated as its sensor, and the unit is reading a signal that is out of range for this input (temp. < -55°F or temp > 150°F).

UCM Reaction: The functions with the RTM zone temperature input designated as their sensor are disabled.

Reset Required: (PAR) an automatic reset occurs after the designated zone temperature signal returns to its allowable range. To prevent rapid cycling of the diagnostic, there is a 10 second delay before the automatic reset.

## S

### SCM Communication Failure

Problem: The RTM has lost communication with the SCM.

Check: Check field/unit wiring between the RTM and SCM.

Reason for Diagnostic: The RTM has lost communication with the SCM.

UCM Reaction: A "lockout" request is sent to the compressor staging control function. A failsafe function in the SCM will cause all SCM outputs to be zeroed and deenergized.

Reset Required: (PAR) An automatic reset occurs after communication has been restored.

### Space Static Press Setpt Failure

Problem: The active space static pressure setpoint is out of range.

Check: Check setpoint value. Also, if space pressure setpoint source is GBAS, but this setpoint has not been assigned to any of the four analog inputs on GBAS, this message will occur.

Reason for Diagnostic: The unit is reading a signal that is out of range for the space static pressure setpoint (input < 0.03 iwc or input > 0.20 iwc).

UCM Reaction: The default space pressure setpoint will become the active space pressure setpoint.

Reset Required: (PAR) An automatic reset occurs after the designated space pressure setpoint source sends a signal within range for 10 continuous seconds, or after a different space pressure setpoint source is user-defined.

### Supply Air Pressure Sensor Failure

Problem: The supply air pressure sensor voltage input is out of range.

Check: Check field/unit wiring between the sensor and RTM.

Reason for Diagnostic: The unit is reading a signal that is out of range for the supply air pressure sensor voltage input (input < 40mV or input > 4.75V)

UCM Reaction: The IGVs will drive closed, and the following functions are disabled;  
a. SA pressure control  
b. SA static pressure limit

Reset Required: (PAR) An automatic reset occurs after the SA temp heating setpoint input returns to within range for 10 continuous seconds, or after a different SA temp heating setpoint selection source is user-defined.

### Supply Air Pressure Setpoint Failure

Problem: The SA pressure input signal is out of range.

Reason for Diagnostic: The SA pressure setpoint input is sending a signal that is out of range (Input < 1.0 iwc or input > 4.3 iwc)

UCM Reaction: The default SA pressure setpoint will become the active SA pressure setpoint.

Reset Required: (PAR) An automatic reset occurs after the designated SA pressure setpoint source sends a signal within range for 10 continuous seconds, or after a different SA pressure setpoint source is user-defined.

# Maintenance

# diagnostics

### Supply Air Temp Cool Setpoint Fail

Problem: The active supply air temperature cooling setpoint is out of range.

Reason for Diagnostic: The input designated as the SA temp cooling setpoint is out of range (temp < 35°F or temp > 95°F).

UCM Reaction: The default HI-set SA temp cooling setpoint becomes the active SA temp cooling setpoint.

Reset Required: (PAR) An automatic reset occurs after the SA temp cooling setpoint input returns to within range for 10 continuous seconds, or after a different SA temp cooling setpoint selection source is user-defined.

### Supply Air Temp Heat Setpoint Fail

Problem: The active supply air temperature heating setpoint is out of range.

Reason for Diagnostic: The input designated as the SA temp heating setpoint is out of range (temp < 35°F or temp > 185°F).

UCM Reaction: The default HI-set SA temp heating setpoint becomes the active SA temp heating setpoint.

Reset Required: (PAR) An automatic reset occurs after the SA temp heating setpoint input returns to within range for 10 continuous seconds, or after a different SA temp heating setpoint selection source is user-defined.

### Supply Air Temperature Failure

Problem: The supply air temperature sensor input is out of range.

Check: Sensor resistance should be between 830 ohms (200°F) and 345.7 ohms (-40°F). If so, check field/unit wiring between sensor and RTM.

Reason for Diagnostic: The unit is reading a signal that is out of range for the supply air temperature input on the RTM (temp. < -55°F or temp > 209°F).

UCM Reaction: These unit functions are disabled:

- supply air tempering
- economizing
- supply air temperature low limit function (CV units)
- supply air temperature control heating and cooling functions (VAV units)

Reset Required: (PAR) an automatic reset occurs after the designated S/A temperature input returns to its allowable range. To prevent rapid cycling of the diagnostic, there is a 10 second delay before the automatic reset.

### Supply Fan Failure

Problem: There is no supply airflow indication after the supply fan is requested on.

Check: Check belts, linkages, etc. on the supply fan assembly. If these are ok, check field/unit wiring between RTM and supply fan. If the supply fan runs in service mode, then verify airflow proving switch and wiring.

Reason for Diagnostic: The supply airflow input is detected OPEN for 40 continuous seconds during any period of time in which the supply fan binary output is ON. between 830 ohms (200°F) and 345.7 ohms (-40°F). If so, check field/unit wiring between the sensor and MCM.

This input is ignored for up to 5 minutes after the supply fan starts, until airflow is first detected.

UCM Reaction: "Off" or "Close" requests are issued as appropriate to the following functions;

- a. Compressor staging/chilled water control
- b. Heat operation
- c. Supply fan control & proof of operation
- d. Exhaust fan control & proof of operation
- e. Exhaust actuator control
- f. Economizer actuator control
- g. IG V / VFD control

Reset Required: (PMR) A manual reset is required anytime after the diagnostic is set. The diagnostic can be reset at the HI, Tracer Summit, or by cycling power to the RTM.

### Supply Fan VFD Bypass Enabled

- a. Data used (module,packet,byte,bit): RTM
- b. Activation conditions: supply fan VFD bypass has been activated and supply fan vfd bypass is installed.
- c. Time to React: 10 sec < T < 20 sec
- d. Diagnostic text (human interface display) SUPPLY FAN VFD BYPASS ENABLED"
- e. Actions to be Initiated: NONE
- f. Reset: The INFO diagnostic is cleared when the supply fan VFD bypass is deactivated.

## T

### LCH Module Comm Failure

Problem: The RTM has lost communication with the LCI-I.

Check: Check field/unit wiring between RTM and LCI-I module.

Reason for Diagnostic: The RTM has lost communication with the LCI-I module.

UCM Reaction: All active commands and setpoints provided by Tracer Summit through the LCI-I will be cancelled and/or ignored. And where Tracer Summit has been designated as setpoint source, local HI default setpoints will be used.

Reset Required: (PAR) An automatic reset occurs after communication has been restored.

### Tracer Communications Failure

Problem: The LCI-I has lost communication with Tracer Summit.

Check: Tracer Summit (building control panel) is powered up and running properly. If so, check unit wiring between LCI-I and Tracer Summit (building control panel).

Reason for Diagnostic: The LCI-I has lost communications with Tracer Summit for > 15 minutes.

UCM Reaction: All active commands and setpoints provided by Tracer Summit through the LCI-I will be cancelled and/or ignored. And where Tracer Summit has been designated as the setpoint source, local HI default setpoints are used.



# Maintenance

# diagnostics

Reset Required: (PAR) An automatic reset occurs after communication between Tracer Summit and the LCI-I is restored.

## U

### Unit HI Communications Failure

Problem: The RTM has lost communication with the unit mounted (local) human interface (HI).

Check: Field/unit wiring between RTM and local HI.

Reason for Diagnostic: The RTM has lost communication with the unit-mounted human interface.

UCM Reaction: A fail-safe function in the HI will cause the following sequence:

- disallow any interaction between the HI and the RTM (or any other modules),
- render all HI keystrokes ineffective
- cause the following message to display on the unit-mounted HI display: "Local HI communications loss. Check comm link wiring between modules." If the unit has a remote HI option, then this diagnostic will display as any other automatic reset diagnostic.

Reset Required: (INFO) An automatic reset occurs after communication is restored between the RTM and the HI. When the failure screen clears, the general display restores to allow the HI to interact with the RTM again.

### Unoccupied Zone Cool Setpoint Failure

Problem: The unoccupied zone cooling setpoint input is out of range.

Reason for Diagnostic: The input designated as the unoccupied zone cooling setpoint source is out of range (temp < 45°F or temp > 94°F).

UCM Reaction: The active unoccupied zone cooling setpoint reverts to the default value.

Reset Required: (PAR) An automatic reset occurs after the designated unoccupied zone cool setpoint input returns to its allowable range for 10 continuous seconds, or after the user defines a

different, valid unoccupied zone cool setpoint selection source.

### Unoccupied Zone Heat Setpoint Failure

Problem: The unoccupied zone heating setpoint input is out of range.

Reason for Diagnostic: The input designated as unoccupied zone heating setpoint source is out of range (temp < 45 F or temp > 94 F).

UCM Reaction: The active unoccupied zone heating setpoint reverts to the default value.

Reset Required: (PAR) An automatic reset occurs after the designated unoccupied zone heat setpoint input returns to its allowable range for 10 continuous seconds, or after the user defines a different, valid unoccupied zone heating setpoint selection source.

## V

### VCM Communication Failure

Problem: The RTM has lost communication with the VCM.

Verify: Check field/unit wiring between RTM and VCM.

Reason for Diagnostic: The RTM has lost communication with the VCM.

UCM Reaction: All active commands and setpoints provided by the VCM are canceled and/or ignored. A fail-safe function in the VCM will cause all outputs to deenergize and/or set to zero. The outside air damper minimum position function will revert to using the O/A flow compensation function if O/A flow compensation is enabled or set to the default minimum position function if O/A flow compensation is disabled or not available.

Reset Required: (PAR) An automatic reset occurs after communication is restored.

### Velocity Pressure Sensor Failure

Problem: The velocity pressure input signal is out of range.

Check: Check field/unit wiring between sensor and VCM.

Reason for Diagnostic: The unit is reading a signal that is out of range for the velocity pressure transducer input (during calibration: V < 40 mV or V > 420 mV, during operation: V < 40 mV or V > 0.75 V).

UCM Reaction: The minimum airflow control function is disabled. The outside air damper minimum position function reverts to using the O/A flow compensation function if O/A flow compensation is enabled or to the default minimum position function if O/A flow compensation is disabled or not available.

Reset Required: (PAR) An automatic reset occurs after the designated space pressure transducer sends a signal within range for 10 continuous seconds.

### VOM Communications Failure

Problem: The RTM has lost communication with the VCM.

Check: Field/unit wiring between RTM and VCM.

Reason for Diagnostic: The RTM has lost communications with the VOM.

UCM Reaction: Ventilation override actions will not be allowed, and the VO Output relay will be deenergized.

Reset Required: (PAR) An automatic reset occurs after communication has been restored.

## W

### WSM Communications Fail

Problem: The RTM has lost communication with the WSM.

Check: Field/unit wiring between RTM and WSM.

Reason for Diagnostic: The RTM has lost communication with the WSM.

UCM Reaction: The UCM will react as if a freezestat has occurred by issuing:

- An "all heat on" or "mod output full open" request to "heat control"



# Maintenance

# diagnostics

- A "fan off" request to "supply fan control"
- A "close damper" request to "economizer actuator control"
- The water pump to turn on and position all water valves to provide maximum flow through all water source heat exchangers
- Disables preheat function if WSM mixed air temp sensor is selected as preheat sensor

Reset Required: An automatic reset occurs after one complete set of IPC packets is received.

### WSM Mixed Air Temp Sensor Fail

- b. Activation Conditions: temperature < -50°F or temperature > 209°F, and sensor is selected for use by "waterside economizer temperature enable function" or "preheat function"
- c. Time to React: 10 sec < T < 20 sec
- e. Actions to be Initiated: "waterside economizer temperature enable function" uses supply air cooling setpoint instead of mixed air temperature. If mixed air temperature is used for "preheat function", issue a "disable" request to "preheat function".
- f. Reset: An automatic reset occurs after the mixed air temp. input returns to within range continuously for 10 seconds.

### Water Flow Fail

- a. Data used (module,packet,byte,bit): WSM, 01,19, 05
- b. Activation Conditions: The water flow input is detected open ;
  1. at the end of precool water flow initiation state, or

- 2. continuously for five minutes while:
  - water side economizer is open 100%,
  - presetting of a head pressure valve, or
  - demand for mechanical cooling.
 Unit must be: a. configured with water cooled condenser and/or water economizer and b. have water flow switch installed.
  - c. Time to React: immediate
  - e. Actions to be Initiated: A "lockout all ckts" request is issued to the "compressor staging function"
  - f. Reset: An automatic reset occurs after the water flow input returns to within range continuously for 3 seconds, the water pump is requested OFF, or the water flow switch becomes not installed.

## Z

### Zone Cool Setpoint Failure

Problem: The occupied zone cooling setpoint is out of range.

Reason for Diagnostic: The input designated as occupied zone cooling setpoint source is out of range (temp. < 45°F or temp > 94°F).

UCM Reaction: The active occupied zone cooling setpoint reverts to the default occupied zone cooling setpoint.

Reset Required: (PAR) an automatic reset occurs after the designated occupied zone CSP input returns to its allowable range for 10 continuous seconds, or after a different valid occupied zone CSP selection source is user-defined.







Literature Order Number	SCXG-SVX01B-EN
Date	March 2008
Supersedes	SCXG-SVX01B-EN July 2000

[www.trane.com](http://www.trane.com)

For more information, contact your local Trane office or e-mail us at [comfort@trane.com](mailto:comfort@trane.com)

Trane has a policy of continuous product and product data improvement and reserves the right to change design and specifications without notice.